

BARONESS
Quality on Demand

LM285

5-Reel Gang Rough Mowers

Service manual

Introduction

This manual describes items such as the maintenance and troubleshooting procedures for this machine. The items described in this manual have been systematically categorized into typical maintenance operations. This manual does not describe the disassembly procedures for equipment that is designated as requiring repair by its manufacturer, such as the hydraulic equipment and engine. Contact a Baroness dealer or Kyo-eisha for repairs.

Refer to the Owner's Manual for a description of how to operate, handle, and adjust the machine. Refer to the Parts Catalog if any parts are required.

Kyo-eisha Co., Ltd.

Caution

The information described in this manual is subject to change without prior notice for improvement.

Note that the Baroness product warranty may not apply to defects caused by the use of parts from other companies.



696cq5-001

Warning symbol

This symbol is accompanied by the word "Danger," "Warning," or "Caution." All labels with this symbol describe important safety precautions, so please read such labels carefully and only operate the machine after you have understood them completely. Failure to adequately follow these safety precautions may cause an accident.

Danger

This symbol indicates that serious injury or death will occur if the warning is ignored.

Warning

This symbol indicates that serious injury or death may occur if the warning is ignored.

Caution

This symbol indicates that injury or damage to property may occur if the warning is ignored.

Important

This symbol indicates precautions for setup of the machine.

Contents

Safety	1-1	Specifications	7-2
Safety instruction	1-2	Special tools	7-4
Jacking up the machine	1-5	Removal and installation of each section	7-6
Safety labels and operation labels	1-5	Inspection and repair of each section	7-22
Disposal	2-1	Work machine and mower unit	8-1
Waste disposal	2-2	Maintenance	8-2
Maintenance standards and maintenance	3-1	Specifications	8-2
Unit conversion table	3-2	Special tools	8-2
List of maintenance standards	3-4	Adjustment	8-4
Tightening torques	3-6	Removal and installation of each section	8-4
Jacking up the machine	3-10	Inspection and repair of each section	8-24
Lubrication	3-11	Troubleshooting	9-1
Engine	4-1	Engine problems	9-2
Maintenance	4-2	Travelling problems	9-3
Specifications	4-2	Steering problems	9-4
Special tools	4-3	Work machine and mower unit problems	9-5
General inspection and repair	4-3	Reference	10-1
Inspection and repair of each section	4-4	Specifications	10-2
Removal and installation of each section	4-10	Maintenance schedule	10-3
Hydraulic system	5-1	Hydraulic circuit diagram	10-5
Maintenance	5-2	Electrical circuit diagram	10-6
Specifications	5-3	Electrical wiring diagram	10-7
General instructions	5-8	Consumable parts list	10-8
Hydraulic circuit flow	5-13		
Special tools	5-21		
Measurement method	5-23		
Adjustment	5-39		
General inspection and repair	5-40		
Inspection and repair of each section	5-42		
Removal and installation of each section	5-44		
Electrical system	6-1		
Maintenance	6-2		
Specifications	6-3		
Special tools	6-6		
Measurement method	6-6		
Adjustment	6-8		
Electrical components	6-11		
General inspection and repair	6-19		
Main body	7-1		
Maintenance	7-2		

Contents

Safety instruction	1-2
Safety	1-2
Before operating the machine	1-2
When operating the machine	1-3
Maintenance and storage	1-4
Jacking up the machine	1-5
Safety labels and operation labels	1-5

Safety instruction

Safety

Danger

This machine is designed to ensure safe operation and has been tested and inspected thoroughly before shipment from the factory. The machine is equipped with safety devices to prevent accidents. However, whether the machine demonstrates its original performance level depends on the manner in which it is operated and handled, as well as the manner in which it is managed on a daily basis. Inappropriate use or management of the machine may result in injury or death. Observe the following safety instructions to ensure safe operation.

Before operating the machine

1. Read the Owner's operating Manual and other training material carefully. Be familiar with the controls, safety signs, and the proper use of the equipment.
2. If the operator or mechanic can not read English it is the owner's responsibility to explain this material to them.
3. Never allow children or people unfamiliar with these instructions to use or service the machine. Local regulations may restrict the age of the operator.
4. Do not operate the machine under the influence of alcohol or drugs or if you are pregnant.
5. Never operate while people, especially children, or pets are nearby.
6. The owner/user can prevent and is responsible for accidents or injuries occurring to themselves, other people, or property.
7. All operators and mechanics should seek and obtain professional and practical instruction. The owner is responsible for training the users. Such instruction should emphasize.
 - [1] The need for care and concentration when working with ride-on machines.
 - [2] Control of a ride-on machine sliding on a slope will not be regained by the application of the brake. The main reasons for loss of control are
 - Insufficient wheel grip
 - Being driven too fast
 - Inadequate braking
 - The type of machine is unsuitable for its task
 - Lack of awareness of the effect of ground conditions, especially slopes
 - Incorrect hitching and load distribution
8. While operating, always wear substantial footwear, long trousers, hard hat, safety glasses, and ear protection. Long hair, loose clothing, or jewelry may get tangled in moving parts. Do not operate the equipment when barefoot or wearing open sandals.
9. Check that operator's presence controls, safety switches and shields are attached and functioning properly. Do not operate unless they are functioning properly.
10. The safety labels and operation labels should be preserved in their entirety. If they are damaged, become dirty, or peel off, please replace them with new ones.
11. Tighten any nuts, bolts, or screws that become loose to ensure that the machine is always operated under safe conditions.
12. Inspect the area where the equipment is to be used and remove all objects such as rocks, toys and wire which can be thrown by the machine.
13. Repair any sensors that are malfunctioning before operating the machine.
14. Check that the interlock system, safety guards, and covers are installed correctly and that they function properly. Repair these parts if there is a malfunction before operating the machine.
15. If the brake operation is faulty or the parking brake lever has noticeable play, be sure to adjust or repair them before operating the machine.
16. Do not use this machine if it has been modified.
17. Exercise care in the handling of fuel.
 - [1] Store fuel in containers specifically designed for this purpose.
 - [2] Make sure that the fuel pipe is not damaged.
 - [3] Add fuel before starting the engine. Never remove the cap of the fuel tank or add fuel while the engine is running or when the engine is hot.
 - [4] Refuel outdoors only and do not smoke while refueling.
 - [5] Do not add too much fuel.
 - [6] If fuel is spilled, do not attempt to start the engine but move the machine away from the area of spillage and avoid creating any source of ignition until petrol vapours have dissipated.
 - [7] Replace all fuel tanks and container caps securely.
18. Warm the engine on cold days. Set the parking brake while warming the engine.

When operating the machine

1. This machine is not authorized for operation as a special motor vehicle. Do not operate it on public roads.
2. Make sure that the operator sits in the operator's seat when operating the machine. Do not carry passengers.
3. Do not operate the engine in a confined space where dangerous carbon monoxide fumes can collect.
4. Before attempting to start the engine, disengage all attachments, shift into neutral, and engage the parking brake.
5. Only operate in good light, keeping away from holes and hidden hazards.
6. Remember there is no such thing as a safe slope. Travel on grass slopes requires particular care. To guard against overturning:
 - [1] Do not stop or start suddenly when going up or downhill.
 - [2] Machine speeds should be kept low on slopes and during tight turns.
 - [3] Stay alert for humps and hollows and other hidden hazards.
 - [4] Never operate across the face of the slope, unless the machine is designed for this purpose.
 - [5] Never drive the machine on a slope with an angle of gradient that is greater than that specified or in a place where there is a danger of the machine slipping.
 - [6] If instructed to do so in the Owner's Manual, use a counterbalance or wheel balance.
7. Always keep a lookout for hidden hollows or obstacles.
8. Do not take your eyes off the road ahead. Do not operate the machine with no hands.
9. Slow down and use caution when making turns and crossing roads and sidewalks.
10. Use care when approaching blind corners, shrubs, trees, or other objects that may obscure your vision.
11. When using attachments, never direct the discharge at bystanders or allow anyone near the machine while it is operating.
12. Do not crawl under the machine while it is in operation.
13. Before backing up, look down and behind you to check that the path is clear and that you can back up safely. Have someone guide you if it is difficult to check the area behind you.
14. Never operate the machine with damaged guards, shields, or without safety protective devices in place.
15. Be sure all interlocks are attached, adjusted and functioning properly.
16. Do not change the engine governor settings or overspeed the engine. Operating the engine at excessive speed may increase the hazard of personal injury.
17. Do not touch the exhaust system during operation or just after the engine has been turned off. Due to its high temperature, doing so could cause burns.
18. If an unusual vibration occurs, stop the engine immediately, inspect the machine and try to identify the cause. Make repairs if necessary.
19. Wear earmuffs as the noise level experienced in the operator's position during operation may exceed the specified level.
20. Do the following before to stop the engine.
 - [1] Stop on level ground.
 - [2] Disengage the power take-off and lower the attachments.
 - [3] Set the parking brake.
 - [4] Change into neutral
 - [5] Reduce the engine speed.
 - [6] Stop the engine and remove the key.
21. Disengage the drive to each attachment except when operating the machine.
22. Disengage the drive to attachments, stop the engine, and remove the ignition key in the following conditions.
 - [1] Before refueling.
 - [2] Before making adjustment
 - [3] Before cleaning blockages.
 - [4] Before checking, cleaning, or working the machine.
 - [5] After striking a foreign object or if an abnormal vibration occurs.
23. Reduce the throttle setting during engine run-out and, if the engine is provided with a shut-off valve, turn the fuel off at the conclusion of operation.
24. Close the fuel valve before transporting the machine.

Safety

25. Take care when loading or unloading the machine into a trailer or a truck. Load or unload the machine in a flat and safe place. Before loading or unloading, set the parking brake on the truck or trailer, stop the engine, and chock the wheels.
26. When transporting the machine on a truck or a trailer, set the parking brake, stop the engine, and fasten the machine to the truck with a rope or other suitable restraining device that has sufficient strength.
27. When using a running board, select one with sufficient strength, length, and width and that will not cause the machine to slip.
12. Carefully release pressure from components with stored energy.
13. Be sure to depressurize the hydraulic system before performing maintenance operations on it such as removing hydraulic equipment.
14. When checking the hydraulic circuit for pinhole leaks or oil leakage from nozzles, do not use your hands. Use items such as paper or corrugated cardboard to find leakage points. Be extremely careful with high-pressure oil as it may pierce your skin, resulting in an injury.

Maintenance and storage

1. Disengage drives on level ground, lower the attachments, set parking brake, stop engine and remove key from ignition. Wait for all movement to stop before adjusting, cleaning or repairing.
2. Disconnect battery before making any repairs. Disconnect the negative terminal first and the positive last. Reconnect positive first and negative last.
3. To reduce the fire hazard, keep the engine, silencer/muffler, battery compartment fuel storage area, cutting unit and drives free of grass, leaves, or excessive grease. Clean up oil or fuel spillage.
4. Make sure that parts such as wires are not touching each other and that their covers have not come off.
5. When filling the tires with air, do not allow the air pressure in the tires to exceed the specified maximum.
6. Check that all nuts, bolts, and screws are properly tightened to ensure that the machine is always operated under safe working conditions.
7. Keep all parts in good working condition and all hardware tightened. Replace all worn or damaged decals.
8. Check whether line connectors in the hydraulic system are properly tightened. Before applying hydraulic pressure, check the connections of the hydraulic pressure lines and the condition of the hoses.
9. Do not modify the machine.
10. Be careful during adjustment of the machine to prevent entrapment of the fingers between moving blades and fixed parts of the machine.
11. Keep hands and feet away from moving parts. If possible, do not make adjustments with the engine running.
15. Do not change the engine governor setting or operate the engine at a speed higher than this setting. Check the maximum engine speed using a tachometer.
16. Stop the engine and allow it to cool before checking or refilling the engine oil.
17. When the fuel tank needs to be cleaned, do it outdoors.
18. Charge batteries in an open well ventilated area, away from spark and flames. Unplug charger before connecting or disconnecting from battery. Wear protective clothing and use insulated tools.
19. Make sure that the electrolyte is between the "UPPER" and "LOWER" limits. Should your skin or clothes come into contact with electrolyte, immediately wash the affected area with water.
20. Use jack stands to support components when required.
21. Appropriately manage and correctly use the tools necessary for servicing or adjusting the machine.
22. Consult a Barons dealer when major repairs or assistance is required.
23. For safety and maximum performance, use genuine Barons parts and accessories. Note that the Barons product warranty may not apply if parts or accessories from other companies are used.
24. Never store the equipment with fuel in the tank inside a building where fumes may reach an open flame or spark.
25. Allow the engine to cool before storing in any enclosure.
26. When storing the machine, lower the rake.
27. If the engine is provided with a shut-off valve, shut off valve while storing or transporting.
28. When storing the machine for an extended period of time, remove the battery and the ignition key. If the machine is going to be stored with the battery still attached, disconnect the negative battery cable.

29. Only cover the machine with a sheet after hot parts have sufficiently cooled down.

Jacking up the machine

Warning

When replacing a tire or beginning any other maintenance or repairs, be sure to chock the wheels to prevent the machine from moving. Before jacking up the machine, park it on a hard, flat surface such as a concrete floor and remove any obstacles that could prevent you from performing the work safely. When necessary, use an appropriate chain block, hoist, or jack. Support the machine securely with jack stands or appropriate blocks. Failure to do so may cause the machine to move or fall, resulting in injury or death.

Use the jack-up points identified in this manual when jacking up the machine.

Only place a jack under the jack-up points specified. Placing a jack at any other point could result in damage to the frame or other parts.

Safety labels and operation labels

Warning

Safety labels and operation labels are attached to this machine. Make sure that they are preserved in their entirety. If they are damaged, become dirty, or peel off, replace them with new ones.

Part numbers for labels that need to be replaced are listed in the parts catalog.

Waste disposal 2-2

Disposal

Waste disposal

Make sure that waste generated when servicing or repairing the machine is disposed of in accordance with local regulations.

(e.g. waste oil, antifreeze batteries, rubber products, and wires etc.)

Maintenance standards and maintenance

Unit conversion table	3-2
Inch-millimeter conversion table	3-2
US unit-SI unit conversion table	3-3
List of maintenance standards	3-4
Tightening torques	3-6
Standard tightening torques	3-6
Principal tightening torques	3-9
Jack-up the machine	3-10
Jack-up point	3-10
Lubrication	3-11
Grease point	3-11

Maintenance standards and maintenance

Unit conversion table

Inch-millimeter conversion table

1 mm = 0.03937 in.

1 in. = 25.4 mm

Fractions			Decimals	mm	Fractions			Decimals	mm
		1/64	0.015625	0.397			33/64	0.515625	13.097
	1/32		0.03125	0.794		17/32		0.53125	13.494
		3/64	0.046875	1.191			35/64	0.546875	13.891
1/16			0.0625	1.588	9/16			0.5625	14.288
		5/64	0.078125	1.984			37/64	0.578125	14.684
	3/32		0.9375	2.381		19/32		0.59375	15.081
		7/64	0.109275	2.778			39/64	0.609375	15.478
1/8			0.1250	3.175	5/8			0.6250	15.875
		9/64	0.140625	3.572			41/64	0.640625	16.272
	5/32		0.15625	3.969		21/32		0.65625	16.669
		11/64	0.171875	4.366			43/64	0.671875	17.066
3/16			0.1875	4.762	11/16			0.6875	17.462
		13/64	0.203125	5.159			45/64	0.703125	17.859
	7/32		0.21875	5.556		23/32		0.71875	18.256
		15/64	0.234375	5.953			47/64	0.734375	18.653
1/4			0.2500	6.350	3/4			0.7500	19.050
		17/64	0.265625	6.747			49/64	0.765625	19.447
	9/32		0.28125	7.144		25/32		0.78125	19.844
		19/64	0.296875	7.541			51/64	0.796875	20.241
5/16			0.3125	7.938	13/16			0.8125	20.638
		21/64	0.328125	8.334			53/64	0.828125	21.034
	11/32		0.34375	8.731		27/32		0.84375	21.431
		23/64	0.359375	9.128			55/64	0.859375	21.828
3/8			0.3750	9.525	7/8			0.8750	22.225
		25/64	0.390625	9.922			57/64	0.890625	22.622
	13/32		0.40625	10.319		29/32		0.90625	23.019
		27/64	0.421875	10.716			59/64	0.921875	23.416
7/16			0.4375	11.112	15/16			0.9375	23.812
		29/64	0.453125	11.509			61/64	0.953125	24.209
	15/32		0.46875	11.906		31/32		0.96875	24.606
		31/64	0.484375	12.303			63/64	0.984375	25.003
1/2			0.5000	12.700	1			1.000	25.400

Maintenance standards and maintenance

US unit-SI unit conversion table

To Convert			Into		Multiply By
Linear Measurement	Miles	mi	Kilometers	km	1.609
	Yards	yd	Meters	m	0.9144
	Feet	ft	Meters	m	0.3048
	Feet	ft	Centimeters	cm	30.48
	Inches	in	Meters	m	0.0254
	Inches	in	Centimeters	cm	2.54
	Inches	in	Millimeters	mm	25.4
Area	Square Miles	mile ²	Square Kilometers	km ²	2.59
	Square Feet	ft ²	Square Meters	m ²	0.0929
	Square Inches	in ²	Square Centimeters	cm ²	6.452
	Acre	ac	Hectare	ha	0.4047
Volume	Cubic Yards	yd ³	Cubic Meters	m ³	0.7646
	Cubic Feet	ft ³	Cubic Meters	m ³	0.02832
	Cubic Inches	in ³	Cubic Centimeters	cm ³	16.39
Weight	Tons (Short)	sh tn	Metric Tons	ton	0.9078
	Pounds	lb	Kilograms	kg	0.4536
	Ounces (Avdp.)	oz	Grams	g	28.3495
Pressure	Pounds/Sq. In.	psi	Kilopascal	kPa	6.895
	Pounds/Sq. In.	psi	Bar	mdyn/cm ²	0.069
Work	Foot-pounds	lb-ft	Newton-Meters	N-m	1.356
	Foot-pounds	lb-ft	Kilogram-Meters	kgf-m	0.1383
	Inch-pounds	lb-in	Kilogram-Centimeters	kgf-cm	1.152144
Liquid Volume	Quarts	qt (us)	Liters	l	0.9463
	Gallons	gal (us)	Liters	l	3.785
Liquid Flow	Gallons/Minute	gal/min	Liters/Minute	l/min	3.785
Temperature	Fahrenheit	°F	Celsius	°C	1. Subtract 32° 2. Multiply by 5/9

Maintenance standards and maintenance

List of maintenance standards

LM285

Engine	Model	KubotaD1105-T (Diesel Turbo)	
	Maximum no-load engine speed	1,400 – 3,000rpm	
	Amount of engine oil	3.1 L (0.82 U.S.gals) (including the amount in the filter)	Oil classified as CF-grade or higher under the API service classification SAE viscosity classification 10W-30
	Amount of coolant water	6 L (1.59 U.S.gals) (including the amount in the reserve tank)	

Maintenance standards and maintenance

Main unit (including Hydraulic system and Electrical system)	Fuel tank capacity	28 L (7.40 U.S.gals)	JIS No.2 light oil	
	Hydraulic tank capacity	24 L (6.34 U.S.gals)	Equivalent of Shell Tellus 46 (ISO VG46)	
	Selector valve cam	Motors stop at the height of more than 400mm (15.75in) from the ground to the outer end of #4 and 5 mower units.	#4 and 5 mower arm fulcrums	
	Parking brake switch	Forward tilting from vertical line by 10 degrees	Positions of the switch lever and the switch main unit	
		Parking brake lever 2 to 3 notches	Conduction of the first stage	
		Parking brake lever more than 4 notches	Conduction of the second stage	
	Traveling neutral switch	Push-in amount : 2.5mm (0.10 in)	Traveling neutral state	
	Maintenance switch	Push-in amount : 4 to 5mm (0.16 to 0.20 in)	Backlapping state	
	Mower proximity switch	Within 5mm (0.20 in)	Distance between the switch and the magnet for detection	
		From the ground to the outer end of the cutting edge of #3 mower unit 400mm (15.75 in)	Position of the magnet for detection (#3 mower arm fulcrum)	
	Battery	75D23L		
	Tire pressure	STD	Front wheel 120 kPa (17.40lb-in ²)	23×10.50-12 4P
			Rear wheel 150 kPa (21.76 lb-in ²)	23×8.50-12 4P
		O.P	Front wheel 120 kPa (17.40lb-in ²)	24×13.00-12 4P
Rear wheel 150 kPa (21.76 lb-in ²)			23×8.50-12 4P	
Toe-in	0±5 mm (0±0.20 in)			
Traveling pedal rod distance (Distance between the centers of rod ends)	334 mm (13.15 in)		Rod for front wheel	
	567 mm (22.32 in)		Rod for rear wheel	
	419 mm (16.50 in)		Pedal neutral rod	
Spring compression distance (Traveling pedal section)	100 mm (3.94 in)		Compression spring for pedal side	
	75 mm (2.95 in)		Compression spring for pump side	
Mower unit	Gap in the spiral of the cutter adjustment spring	1 mm (0.040 in)	Gap between the spring spiral	

Maintenance standards and maintenance

Tightening torques

Standard tightening torques

Bolts and screws

Unless otherwise instructed, tighten bolts or nuts by the specified torque using an appropriate tool.

Excessive tightening of a screw may cause it to become loose or damaged. The appropriate tightening torque depends on factors such as the type of screw, its strength, and the friction of its thread and bearing surface.



The following list is for galvanized and parkerized bolts only. The values given in this list do not apply to low-strength female screws.

Do not use a screw that has rusted or has foreign matter such as sand on it. Such a screw cannot be fully tightened even if it is tightened by the specified torque. The friction on the thread surface increases, causing a loss of torque that results in an insufficient tightening torque being exerted. If a screw is wet or oily, do not tighten it by the specified torque. If a screw gets wet, the torque coefficient decreases, resulting in excessive tightening of the screw if it is tightened by the specified torque. Excessive tightening of a screw may cause it to elongate, resulting in the screw becoming loose or damaged. Do not use a screw that has already been subjected to a large load.

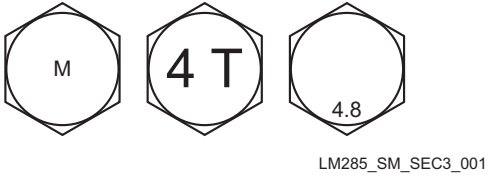
Tightening a bolt with an impact wrench requires skill. Practice tightening bolts to ensure you are able to tighten them reliably.

Nominal diameter	General bolts		
	Strength class: 4.8		
			
	N-m	kgf-cm	lb-in
M5	3 – 5	30.59 – 50.99	26.55 – 44.26
M6	7 – 9	71.38 – 91.77	61.96 – 79.66
M8	14 – 19	142.76 – 193.74	123.91 – 168.17
M10	29 – 38	295.71 – 387.49	256.68 – 336.34
M12	52 – 67	530.24 – 683.20	460.25 – 593.02
M14	70 – 94	713.79 – 958.52	619.57 – 831.99
M16	88 – 112	897.34 – 1142.06	778.89 – 991.31
M18	116 – 144	1,182.85 – 1,468.37	1,026.72 – 1,274.54
M20	147 – 183	1,498.96 – 1,866.05	1,301.10 – 1,619.73
M22	295	3,008.12	2,611.05
M24	370	3,772.89	3,274.87
M27	550	5,608.35	4,868.05
M30	740	7,545.78	6,549.74

Maintenance standards and maintenance

Nominal diameter	Heat-treated screws					
	Strength category: 8.8			Strength category: 10.9		
	 LM285_SM_SEC3_002			 LM285_SM_SEC3_003		
N-m	kgf-cm	lb-in	N-m	kgf-cm	lb-in	
M5	5 – 7	50.99 – 71.38	44.26 – 61.96	7 – 10	71.38 – 101.97	61.96 – 88.51
M6	8 – 11	81.58 – 112.17	70.81 – 97.36	14 – 18	142.76 – 183.55	123.91 – 159.32
M8	23 – 29	234.53 – 295.71	203.57 – 256.68	28 – 38	285.52 – 387.49	247.83 – 336.34
M10	45 – 57	458.87 – 581.23	398.30 – 504.51	58 – 76	591.43 – 774.97	513.36 – 672.68
M12	67 – 85	683.20 – 866.75	593.02 – 752.34	104 – 134	1,060.49 – 1,366.40	920.50 – 1186.03
M14	106 – 134	1,080.88 – 1,366.40	938.21 – 1,186.03	140 – 188	1,427.58 – 1,917.04	1,239.14 – 1,663.99
M16	152 – 188	1,549.94 – 1,917.04	1,345.35 – 1,663.99	210 – 260	2,141.37 – 2,651.22	1,858.71 – 2,301.26
M18	200 – 240	2,039.40 – 2,447.28	1,770.20 – 2,124.24	280 – 340	2,855.16 – 3,466.98	2,478.28 – 3,009.34
M20	245 – 295	2,498.27 – 3,008.12	2,168.50 – 2,611.05	370 – 450	3,772.89 – 4,588.65	3,274.87 – 3,982.95
M22	—	—	—	530	5,404.41	4,691.03
M24	—	—	—	670	6,831.99	5,930.17
M27	—	—	—	1,000	10,197.00	8,851.00
M30	—	—	—	1,340	14,628.78	11,860.34

Reference: The above values also apply for fine screw threads.

Maintenance standards and maintenance

Hydraulic hose

The tightening torques for union joints and union adaptors with parallel pipe threads (G, PF) are shown in the table below.

A union joint or adaptor will not become loose or leak as long as it is tightened by the specified torque. If fluid leaks from the sealed portion, do not attempt to tighten the union joint or adaptor forcibly. Examine whether any foreign matter or scratches are present on the seat surface. Tightening a union joint or adaptor forcibly could damage the connection of the joints.

When tightening a union joint or adaptor, use a torque wrench where possible and firmly tighten it by an appropriate torque.

Nominal diameter	Nominal diameter of the parallel pipe threads	Tightening torque		
		N-m	kgf-cm	lb-in
5.5	1/4	24.50	250	221.28
8.9	3/8	49.03	500	564.91
12.0	1/2	58.84	600	677.89
15.0	3/4	117.68	1,200	1,355.78
19.0	3/4	117.68	1,200	1,355.78
25.0	1	137.30	1,400	1,581.74
32.0	1-1/4	166.72	1,700	1,920.69
38.0	1-1/2	205.94	2,100	2,372.61
50.0	2	245.17	2,500	2,824.54

Fittings with parallel threads (O-ring seal type)

The tightening torques for fittings with parallel threads (O-ring seal method) are shown in the table below.

Tightening an adjustable joint forcibly with a spanner or other such tool to secure it to a set position could damage the adjustable joint, its washers, and other parts. Be sure to tighten an adjustable joint to the torque appropriate to its size.

Nominal diameter of thread	Tightening torque		
	N-m	kgf-cm	lb-in
1/4	34.32 – 49.03	350 – 500	309.79 – 442.55
3/8	68.65 – 78.45	700 – 800	619.57 – 708.08
1/2	98.07 – 117.68	1,000 – 1,200	885.10 – 1,062.12
3/4	147.10 – 176.52	1,500 – 1,800	1,327.65 – 1,593.18
1	245.17 – 274.59	2,500 – 2,800	2,212.75 – 2,478.28
1-1/4	294.20	3,000	2,655.30
1-1/2	294.20	3,000	2,655.30
2	392.27	4,000	3,540.40

Maintenance standards and maintenance

Principal tightening torques

■ LM285

Tighten the following bolts and nuts at the torque specified in the table.

For thread locking adhesive, apply a middle strength thread locker (ThreeBond 1322 anaerobic adhesives).

Portion		Code	Part name	Tightening Torque			Thread locking adhesive
				N-m	kgf-cm	lb-in	
Front wheel	Motor	K0013120602	Bolt, 11T, heat-treated M12-60	104 – 134	1,060.49 – 1,366.40	920.50 – 1,186.03	—
	Wheel mounting base	K0160000492	24 special nut P1.5	180 – 200	1,835.46 – 2,039.40	1,593.18 – 1,770.20	○
	Wheel	K0034120302	Bolt, 8T, heat-treated M12-30P1.5	67 – 85	683.20 – 866.75	593.02 – 752.34	—
Rear wheel	Wheel mounting base	K0138240002	24 slotted nut high P1.5	180 – 200	1,835.46 – 2,039.40	1,593.18 – 1,770.20	—
	Wheel	K0034120302	Bolt, 8T, heat-treated M12-30P1.5	67 – 85	683.20 – 866.75	593.02 – 752.34	—
Tie rod		K1610000020	Tie rod end right ass'y	45	158.87	398.30	—
		K1611000020	Tie rod end left ass'y	45	158.87	398.30	—
Lever damper		K0144080002	8U nut	—	—	—	○
Engine		K0017100252	Bolt, heat-treated, small, 10-25 P1.25	45 – 57	158.87 – 581.23	398.30 – 504.51	—
				Since it may be difficult to tighten bolts and nuts in the upper front left area of the engine, the strength category should be 4.8 torque. (See “Standard tightening torques” (Page 3-6).)			
		K4040000150	Nut for attaching anti-vibration rubber	28 – 38	285.57 – 387.49	247.83 – 336.34	○
Coupling		K0024100351	Bolt, 12T, w/hexagon hole, M10-35	60 – 70	611.82 – 713.79	531.06 – 619.57	—
		K0013100352	Bolt, 11T, heat-treated M10-35	45 – 76	158.87 – 774.97	398.30 – 672.68	—
		K0010100202	Bolt, 11T, heat-treated M10-20	45 – 76	158.87 – 774.97	398.30 – 672.68	○
		K0010080202	Bolt, 11T, heat-treated M8-20	23 – 38	234.53 – 387.49	203.57 – 336.34	○
Bed knife (Bottom blade)		K0071000092	Screw, heat-treated flathead M10-20	29 – 38	295.71 – 387.49	256.68 – 336.34	—
Arm frame Roll bar		K0013120302	Bolt, 11T, heat-treated M12-45	52 – 67	530.24 – 683.20	460.25 – 593.02	—

Maintenance standards and maintenance

Jacking up the machine

Warning

When replacing a tire or beginning any other maintenance or repairs, be sure to chock the wheels to prevent the machine from moving. Before jacking up the machine, park it on a hard, flat surface such as a concrete floor and remove any obstacles that could prevent you from performing the work safely. When necessary, use an appropriate chain block, hoist, or jack. Support the machine securely with jack stands or appropriate blocks. Failure to do so may cause the machine to move or fall, resulting in injury or death.

Use the jack-up points identified in this manual when jacking up the machine.

Only place a jack under the jack-up points specified. Placing a jack at any other point could result in damage to the frame or other parts.

	Jack-up point
1	Front RH frame
2	Front LH frame
3	Rear RH frame
4	Rear LH frame
5	Rear Center frame

1. Front RH frame

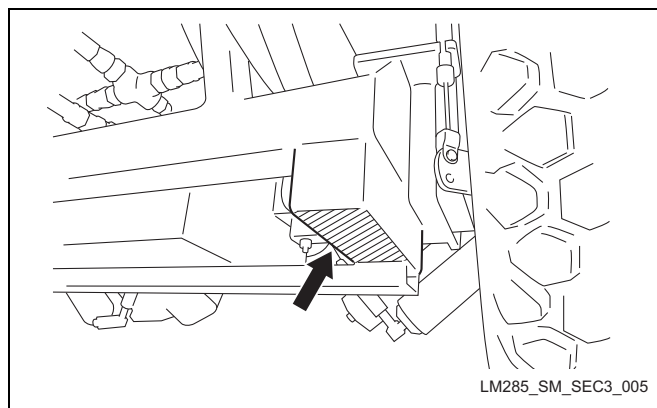

Figure: Maintenance standards and maintenance-2-a

2. Front LH frame

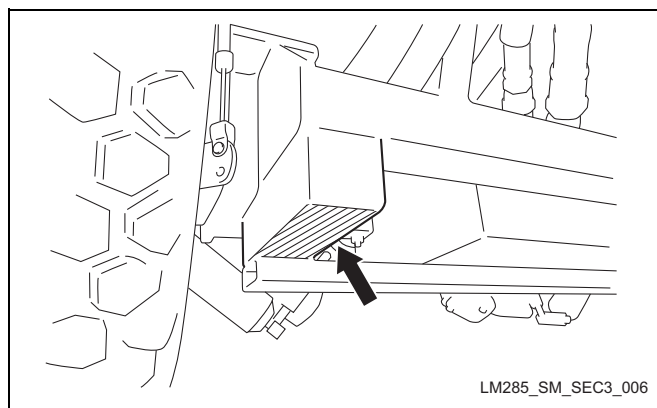

Figure: Maintenance standards and maintenance-3-a

3. Rear RH frame

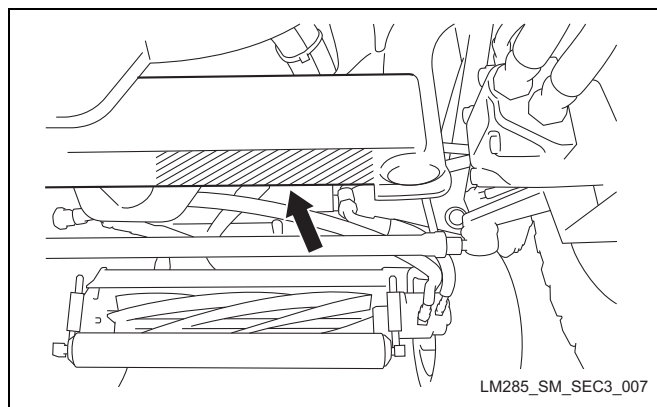

Figure: Maintenance standards and maintenance-4-a

Jack-up point

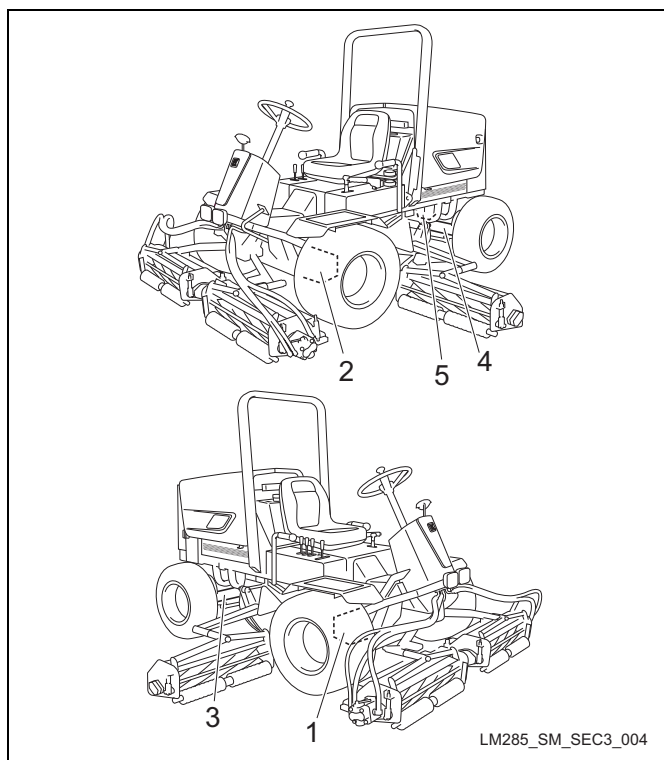

Figure: Maintenance standards and maintenance-1-a

4. Rear LH frame

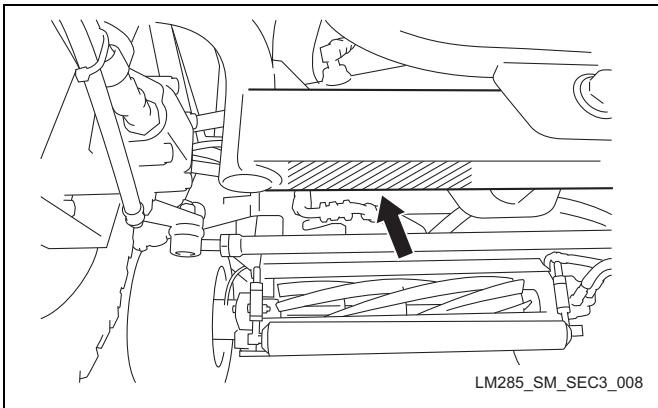

Figure: Maintenance standards and maintenance-5-a

5. Rear center frame

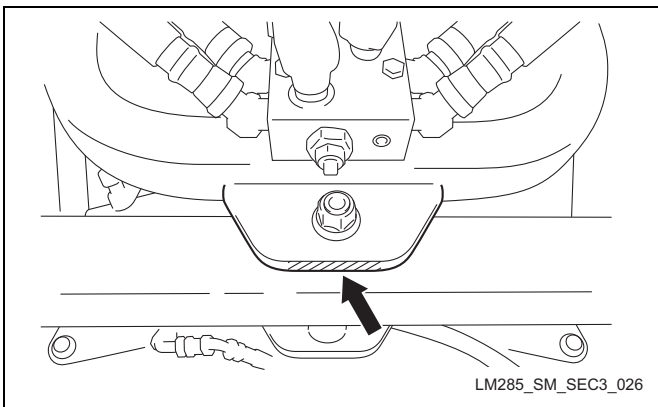

Figure: Maintenance standards and maintenance-6-a

Lubrication

The moving parts of this machine need to be lubricated as a lack of grease on such parts could cause them to seize or be damaged. Grease the moving parts according to the maintenance schedule.

Grease point

Grease nipples are installed in the following positions. Grease them every 50 hours.

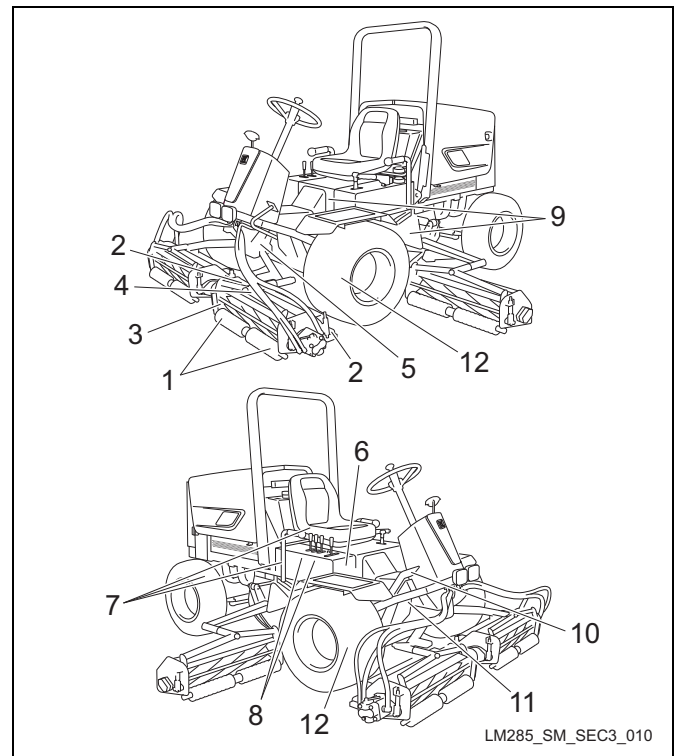

Figure: Maintenance standards and maintenance-7-a

	Parts	Number of grease points
1	Front roller	10
2	Rear roller	10
3	Reel housing	5
4	Mower arm fulcrum	5
5	Lift arm fulcrum	5
6	Idle lever fulcrum	1
7	Pivot	3
8	Piston pump	2
9	Unload lever fulcrum	2
10	Traveling pedal fulcrum	1
11	Traveling pedal axle fulcrum	1
12	Brake lever axle	2

Maintenance standards and maintenance

1. Front roller

One point at the both sides of each unit.

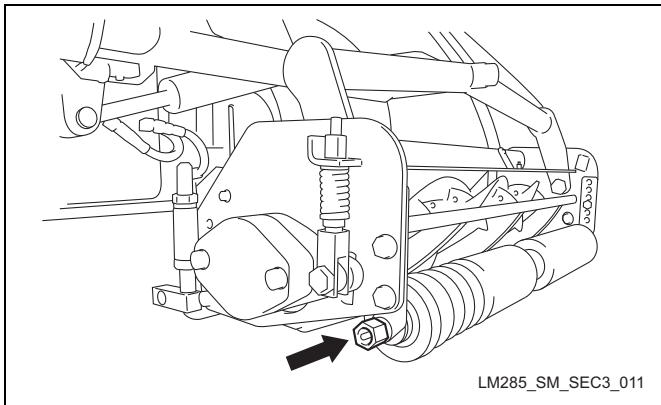

Figure: Maintenance standards and maintenance-8-a

2. Rear roller

One point at the both sides of each unit.

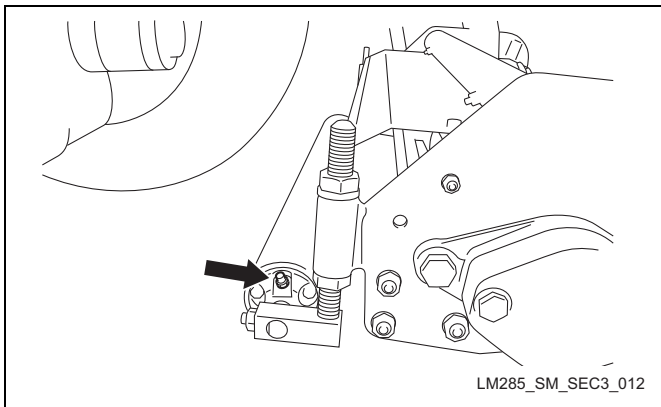

Figure: Maintenance standards and maintenance-9-a

3. Rear housing

One point in each unit.

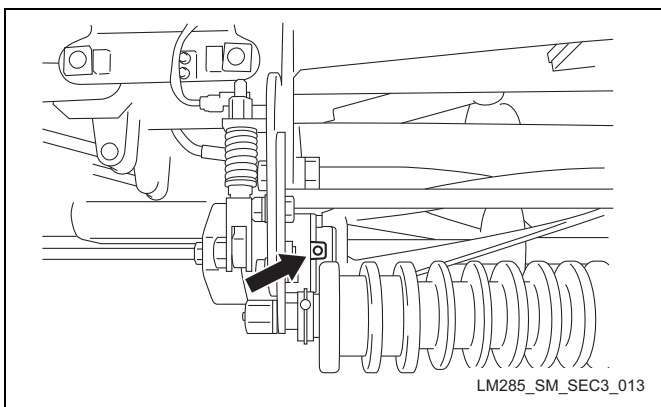

Figure: Maintenance standards and maintenance-10-a

4. Mower arm fulcrum

One point in each unit.

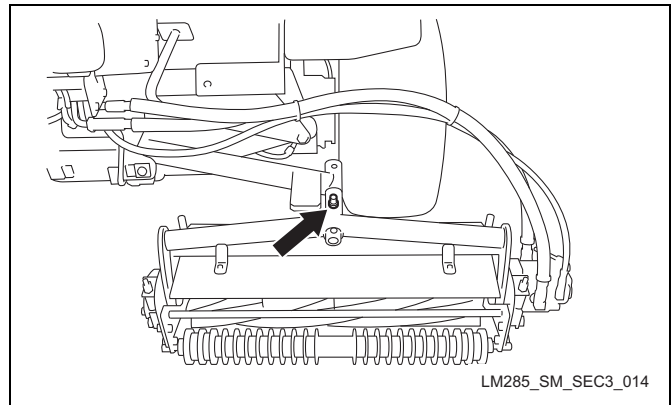

Figure: Maintenance standards and maintenance-11-a

5. Lift arm fulcrum

One point in each arm connected to each unit.

#1 mower

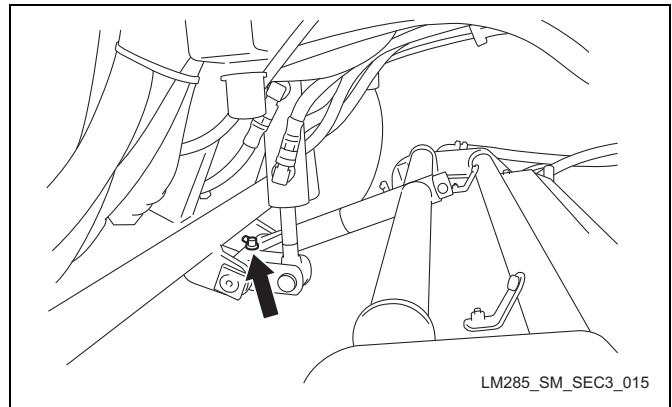

Figure: Maintenance standards and maintenance-12-a

#2 and 3 mowers

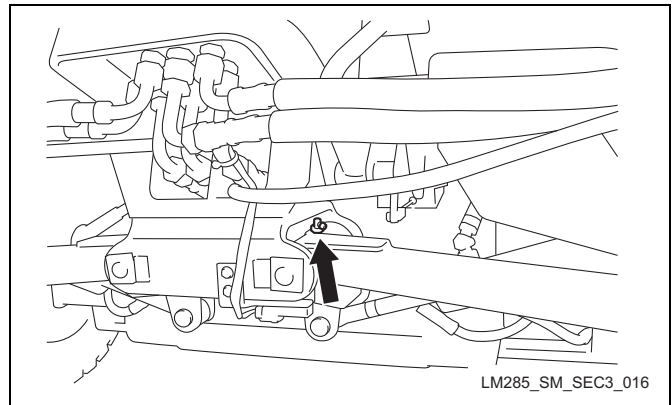

Figure: Maintenance standards and maintenance-13-a

Maintenance standards and maintenance

#4 and 5 mowers

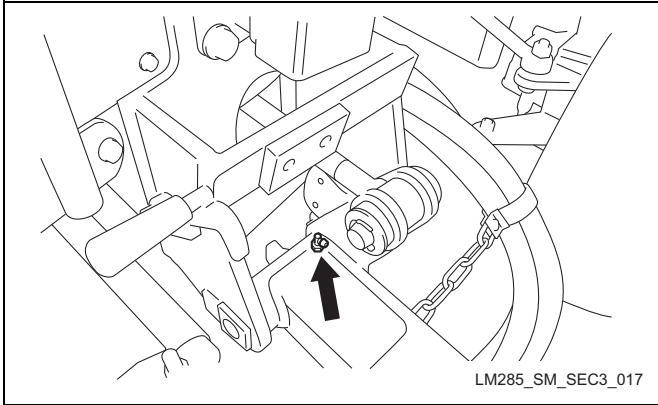

Figure: Maintenance standards and maintenance-14-a

Rear LH

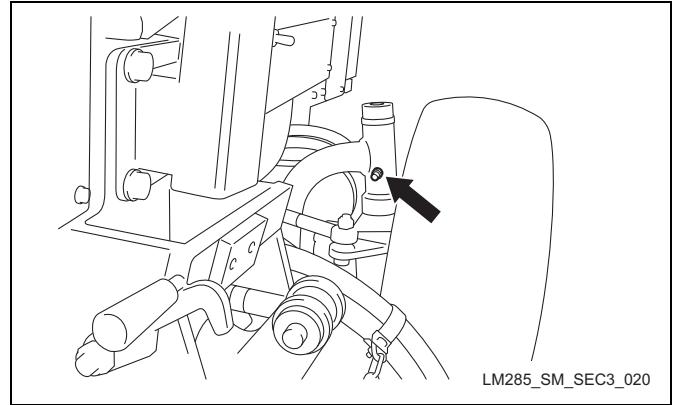

Figure: Maintenance standards and maintenance-17-a

6. Idle lever fulcrum

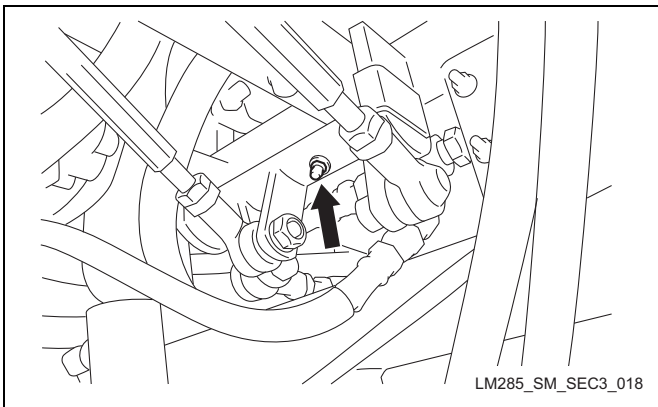

Figure: Maintenance standards and maintenance-15-a

Rear RH

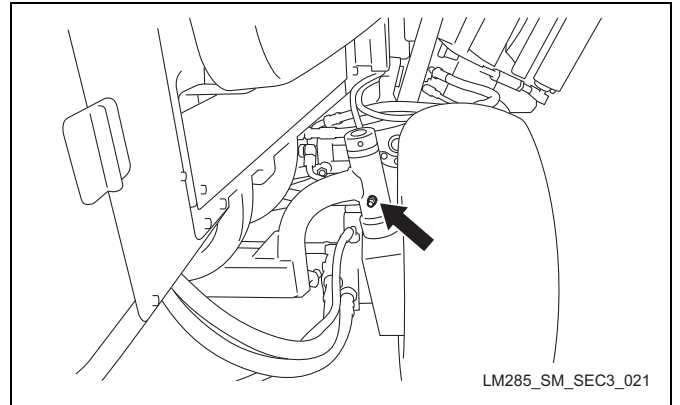

Figure: Maintenance standards and maintenance-18-a

7. Pivot

Jack up and then grease.

Rear center

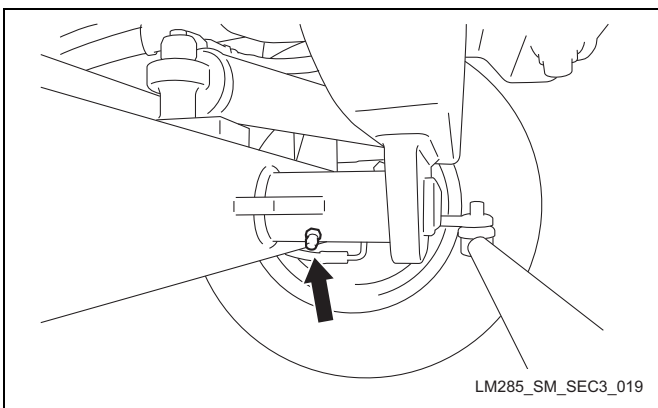

Figure: Maintenance standards and maintenance-16-a

8. Piston pump (under the seat)

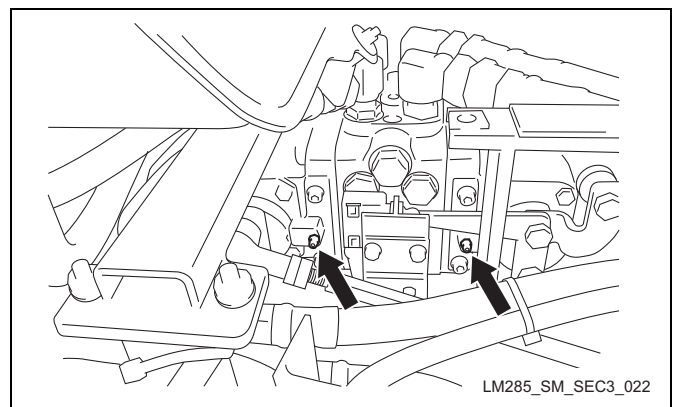

Figure: Maintenance standards and maintenance-19-a

Maintenance standards and maintenance

9. Unload lever fulcrum

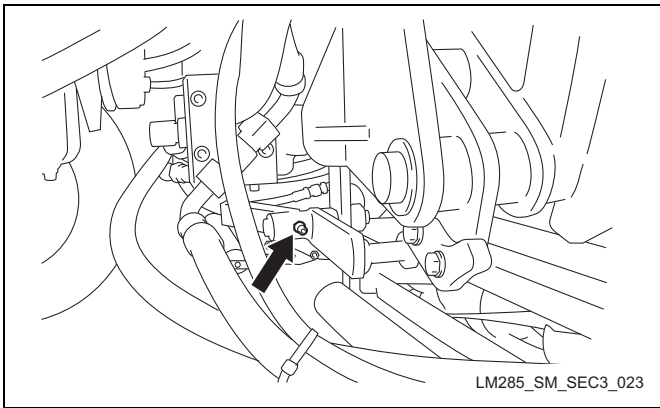

Figure: Maintenance standards and maintenance-20-a

12. Brake lever axle

One point each in the RH & LH brakes

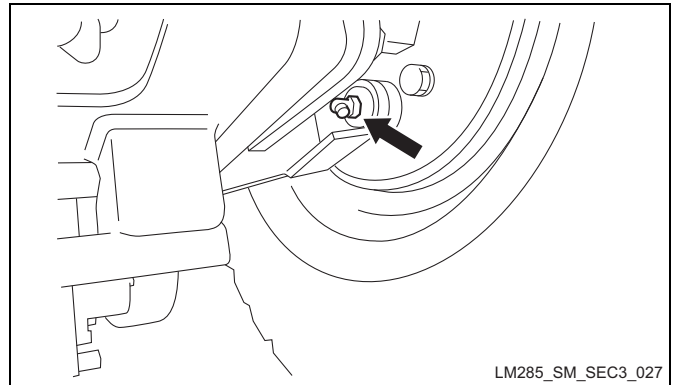

Figure: Maintenance standards and maintenance-23-a

10. Traveling pedal fulcrum

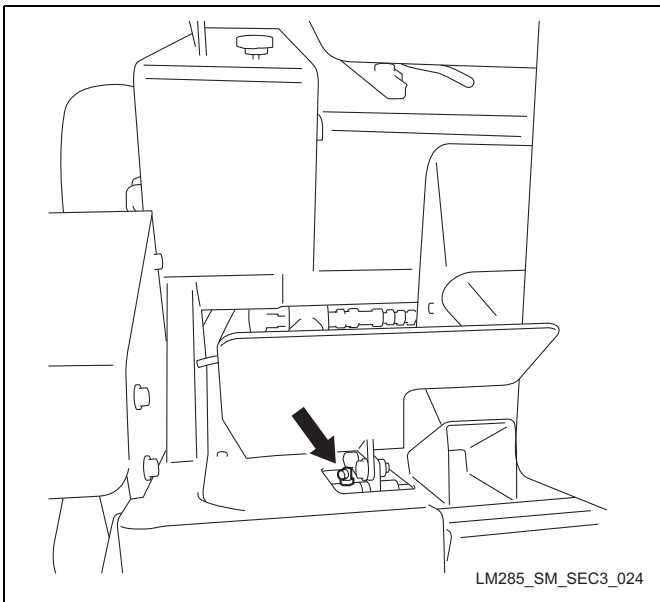

Figure: Maintenance standards and maintenance-21-a

11. Traveling pedal axle fulcrum

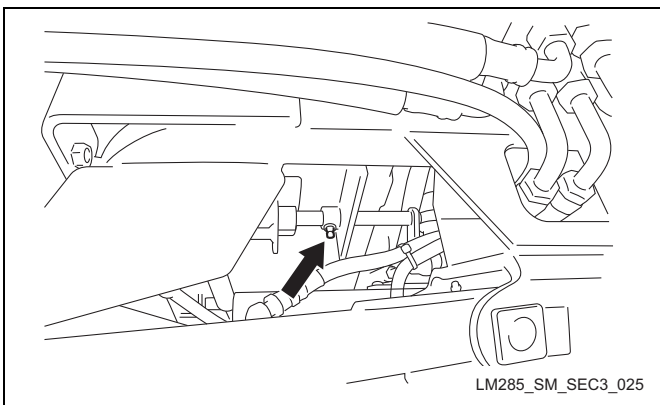

Figure: Maintenance standards and maintenance-22-a

Maintenance	4-2
Specifications	4-2
Special tools	4-3
General inspection and repair	4-3
Cooling system	4-3
Air cleaner	4-4
Fuel tank	4-4
Inspection and repair of each section	4-4
Cooling system	4-4
Air cleaner	4-5
Fuel filter	4-6
Fuel pipe	4-6
Engine oil	4-7
Engine oil filter	4-9
Radiator	4-9
Removal and installation of each section	4-10
Engine	4-10
Radiator	4-13

Engine

Maintenance

Kubota D1105-T (Diesel turbo) engine is mounted on this equipment.

For details, refer to the owner's and service manual of the engine.

Danger

Observe the following safety instructions for safe inspection and maintenance.

1. Move the machine to a level surface to prepare for adjustment and maintenance.

Apply the parking brake, stop the engine and remove the key. Make sure that each part has completely stopped moving before starting the procedures for adjustment, maintenance and so on.

2. Keep away from moving parts. Avoid adjustment as much as possible while the engine is running. Keep people away from the area.

3. Use an appropriate chain block, hoist and jack as needed. Securely support the lifted machine with a jack stand or an appropriate block.
4. Use only BARONESS genuine parts for replacement and accessories.
5. Do not start the engine in an enclosed room since poisoning by carbon monoxide may occur.
6. Do not touch the exhaust system while the engine is running or right after the engine has stopped. Its high temperature may cause a burn.
7. Keep flames away from the battery. Batteries emit hydrogen gas and mishandling may ignite it and cause an explosion.
8. The electrolytic solution in the battery is sulfuric acid. Contact with the electrolytic solution (sulfuric acid) may cause blindness or burns. Also, if it comes into contact with the vehicle, it may damage it.

Specifications

Model	D1105-T-E3B
Type	Vertical 4-cycle liquid cooled Diesel
Number of cylinders	3
Bore and stroke	78.0 mm × 78.4 mm (3.07" × 3.09")
Displacement	1,123 cc (68.53 cu.in.)
Dry weight	89.0 kg (196.04 lbs)
Output	24.5 kW / 3,000 rpm (33.3 PS / 3,000 rpm)
Maximum no-load speed	3,200 rpm
Minimum no-load speed	1,400±50 rpm
Combustion system	E-TVCS (Swirl chamber type)
Intake system	Turbocharged (Turbo charged)
Direction of rotation	Counterclockwise (viewed on flywheel)
Injection pump type	Bosch MD type pump
Governor	Flyweight type mechanical governor
Injection nozzle type	Denso OPD mini nozzle
Injection order	1 (Gear case side)-2-3 (Flywheel side)
Compression ratio	23 : 1
Fuel for use	Diesel light oil No.2-D (ASTM D975)
Lubricating device	Forced lubrication by trochoid pump
Lubricating oil	Oil classified as CF-grade or higher under the API service classification SAE viscosity classification 10W-30

Amount of lubricating oil (including the amount in the filter)	3.1 L (0.82 U.S.gals)
Thermostat opening valve temperature	Temperature at the beginning of open :71 °C Temperature of full open :85 °C
Amount of coolant water (including the amount in the reserve tank)	6L (1.59 U.S.gals)
Starter motor	12 V, 1.4 kW
Charging generator	12 V, 40 A

*unit conversion : HP = 0.746 kW, PS = 0.7355 kW

Special tools

No special tools are needed.

General inspection and repair

Cooling system

Liquid cooled engine

The water-cooled type cooling device consists of water jacket, radiator, water pump, thermostat, cooling fan, radiator hose etc. to keep the engine at the proper temperature.

To prevent the engine from overheating, always keep the radiator, oil cooler, radiator cover and other external surface clean.

Reference: Refer to the owner's manual for the cleaning cycle, procedure and so on.

Warning

In case that the engine overheats, steam may blow out from the radiator and/or the reserve tank and cause burns.

Caution

Do not stop the engine suddenly. Stop it after terminating the load and implementing cooling operation like idling etc.

Important

Starting the engine with a dirty radiator, oil cooler and radiator cover may cause the engine to overheat and become faulty. It may also cause failure of the hydraulic system.

Important

Do not clean the engine with a pressure washer. Water may enter its fueling system.

1. Move this equipment to a level surface. Apply the parking brake, stop the engine and remove the key.

Warning

Do not touch the engine and exhaust system. Their high temperature may cause burns. Let them cool sufficiently before performing work.

Caution

Cool the engine and the radiator sufficiently and then perform work.

Important

Loosen the cap slowly to the first stop and terminate the pressure completely at that time. And then turn it again to remove.

2. Uncap the radiator and confirm it is filled with the coolant water up to the cap level.
3. In the case that it is equipped with a reserve tank, confirm that the coolant water level is between FULL and LOW of the reserve tank.
4. In the case that the amount of the coolant water in the radiator and the reserve tank is not sufficient, refill with clean water like tap water etc.

Engine

Air cleaner

A dirty air cleaner element could cause the engine to malfunction. Clean it properly to prolong the engine life.

Important

A properly maintained air cleaner protects the parts inside the engine from dust particles in the air.

If cautionary notes on handling the air cleaner are not strictly observed, dirt and dust may be drawn into the engine and mix with the oil. Dirt in the oil forms a composite with abrasibility, and will wear out the rotating parts rather than protecting them.

Be sure to inspect and clean the air cleaner.

Reference: Cleaning cycle, procedures and the like of are described in the Owner's manual.

Fuel tank

Danger

Handle fuel carefully since it is highly flammable. Always fill fuel outside and make sure there are no flames present during work. Do not open the fuel tank lid while the engine is running or is still hot. Feed fuel before starting work. Do not start the engine when fuel has been spilled. Start the engine only after moving it some distance away from any spilled fuel, and properly treat the spilled fuel. Securely close the lid of the fuel tank and fuel container.

Checking of the fuel line and connection

Check the fuel line and its connection regularly. Check for deterioration, damage, leakage or poor connections, and replace the hose, stopper and connector part as appropriate.

Draining of fuel and cleaning of the fuel tank

Important

Make sure that fuel is drained outside.

Drain fuel and clean the fuel tank regularly. Drain fuel and clean the fuel tank if the fuel system is dirty or if equipment is to be stored for a long time.

Use a pure solvent such as kerosene to clean the fuel tank and fuel hose. Sediment causes the fuel tank to get dirty.

Muffler

Warning

Do not touch the engine or exhaust system. The high temperature may cause injury. Start work only after they have cooled down.

Important

Do not clean the engine with a pressure washer. Water may penetrate into the fueling system.

Check the welded part of the muffler fitting bracket and muffler adaptor for cracks or damage. Check for cracks in the muffler joint, loosening of inner parts, or cracks of welded parts. Replace if broken.

Inspect and clean the area around the muffler and make sure it is free from scraps or dust.

Inspection and repair of each section

Cooling system

Clean the engine section, oil cooler, radiator and radiator cover every day. Clean them more frequently if they are very dirty.

Inspect the tension of the fan belt. Remove the accumulated clippings etc. especially around the V belt and the engine immediately. If not implemented, they may cause a fire.

Cleaning of the cooling system

The cooling system may be clogged with clippings, straw dust and so on during mowing dry grasses or long operation in dirty air. The operation with a clogged cooling system may cause overheat and damage the engine.

To reduce overheat risk and to prevent accumulated dust from catching fire, remove the dust around the engine periodically after the engine cools down.

Caution

Clean with a brush or compressed air. Do not use water for cleaning engine parts because water may enter the fueling system. Use a brush or dry cloth.

Cleaning of the radiator, oil cooler and radiator cover

Surely remove the dust on the radiator, oil cooler and radiator cover.

During operation in dusty places, remove dust frequently.

⚠ Caution

Operation without cleaning may cause the engine overheat and adhesion. It may also cause failure of hydraulic equipments.

Important

Do not clean the radiator and oil cooler with such a hard tool as a paddle, screwdriver and so on. It may damage the special fin and tube and cause decreasing the cooling ability and leakage of coolant water.

Open the radiator cover (1), loosen the knob (3) of the oil cooler (2) and tilt the oil cooler (2). Clean the radiator cover (1), the oil cooler (2) and the both sides of the radiator (4) with a brush or compressed air in a careful manner.

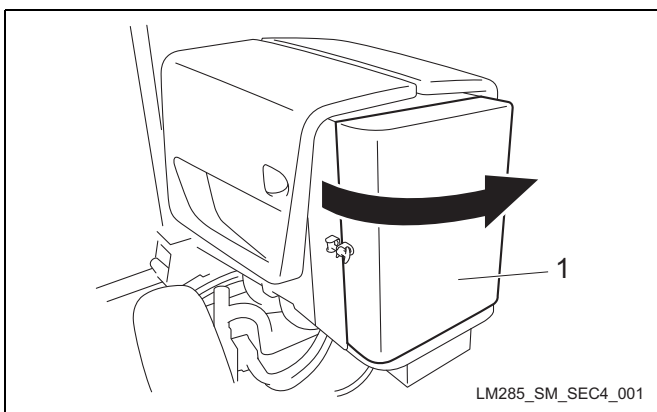

Figure: Engine-1-a

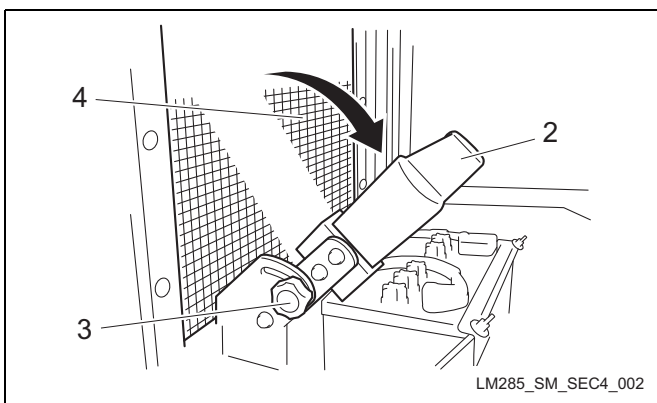

Figure: Engine-2-a

1	Radiator cover
2	Oil cooler
3	Knob
4	Radiator

Fan and fan belt

⚠ Caution

After removing the protective cover during the inspection and maintenance work, put it back in place and surely install it. The cover protects the fan and belt. Operation without the protective cover may cause damage or failure.

Important

Looseness and damage of the belt and damage of the fan may cause overheat and a weak battery.

Inspection of the fan and fan belt should be implemented at the state of the engine stop and before starting it.

1. According to the periodical inspection list, confirm that the belt (1) is not cracked and chipped and that the blade (2) of the fan is not damaged or cracked. If damaged, replace it with a new one. Surely install the protective cover if it used.
2. The adequate flexure is about 10 mm (0.39 in) with 98.07N (10 kgf, 22.05 lbf) when pressing the center of the belt (1) with a finger.
3. In the case that the flexure is too large, loosen the nut (4) and the bolt (5) fastening the alternator (3) and move the alternator (3) for adjustment. After adjustment, surely tighten the nut (4) and the bolt (5).

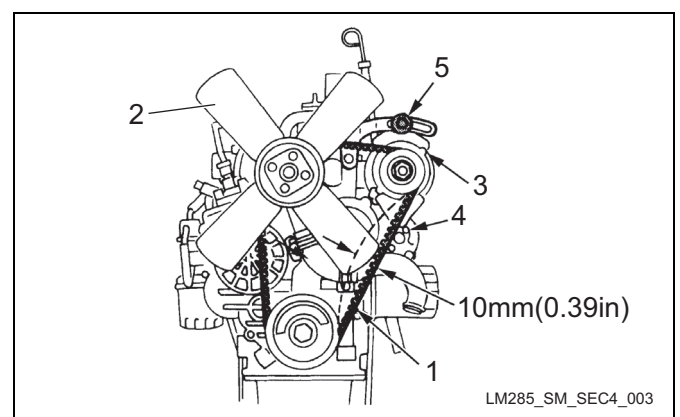

Figure: Engine-3-a

Air cleaner

The air cleaner is a device that removes dust contained in the suctioned air, thereby reducing wear of cylinder liners and piston rings to keep the engine in good condition. A dirty air cleaner element may cause malfunction of the engine.

Clean the air cleaner element before use and replace it every 200 hours. Cleaning and replacement need to be

Engine

done at shorter intervals if the contamination is heavy. Replace the air cleaner element after one year of use regardless of the specified hours

Cleaning and replacement of the air cleaner element

1. Remove the two clips (2), the air cleaner cap (3) and the air cleaner element (1).
2. Taking care not to damage the element (1), tap on the solid part of the element (1) or blow air to its inside to remove dust and scraps. If it is extremely dirty or its replacement time has arrived, replace it with a new one.
3. Install the air cleaner element (1) to the air cleaner body (4).
4. Install the air cleaner cap (3) and fix it surely with the clips (2).

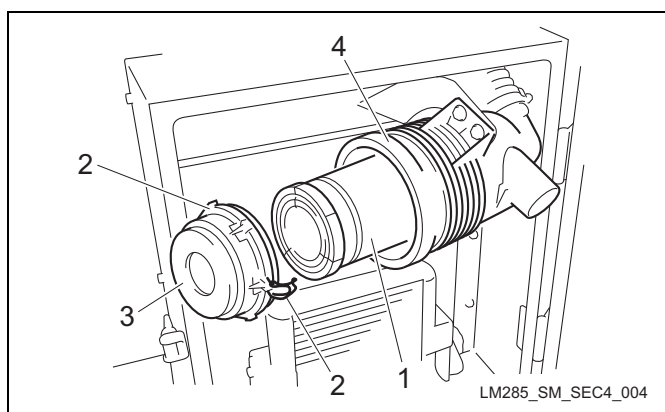

Figure: Engine-4-a

1	Air cleaner element
2	Clip
3	Air cleaner cap
4	Air cleaner body

Fuel filter

Inspection and replacement of the fuel filter

Remove the rubber catch small (1), open the bonnet COMP right (2) and prop it with the bonnet stay (3).

Replace the fuel filter (4) every 500 hours or immediately regardless of the specified hours if the flow of fuel is bad.

The fuel filter cannot be disassembled for cleaning. Install it taking care of the direction of the filter.

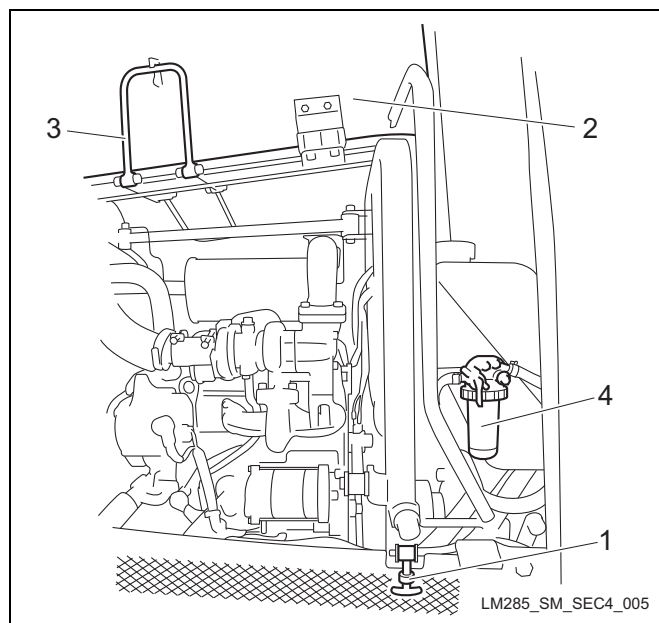

Figure: Engine-5-a

1	Rubber catch small
2	Bonnet COMP right
3	Bonnet stay
4	Fuel filter

Fuel pipe

Inspection and replacement of the fuel pipe

⚠ Danger

A damaged fuel pipe may cause fuel leakage and may catch fire.

For tightening inspection of the fuel pipes (1) and the tightening bands (2) of the fuel pipes, first check after 50 hours and then every 100 hours or every 6 months whichever comes first.

1. If the tightening bands (2) are loose, tighten them surely, applying oil to the threads.
2. If the fuel pipes (1) and the tightening bands (2) are damaged and/or the fuel pipes are not surely installed, replace, repair and service them soon.
3. The fuel pipes (1) made of rubber are consumables which deteriorate even if they are not used. Replace with new ones every 2 years. Also at that time, replace the tightening bands (2) with new ones and tighten surely.

Reference: Manual air-bleeding is not needed since this vehicle is equipped with an auto air-bleeding device.

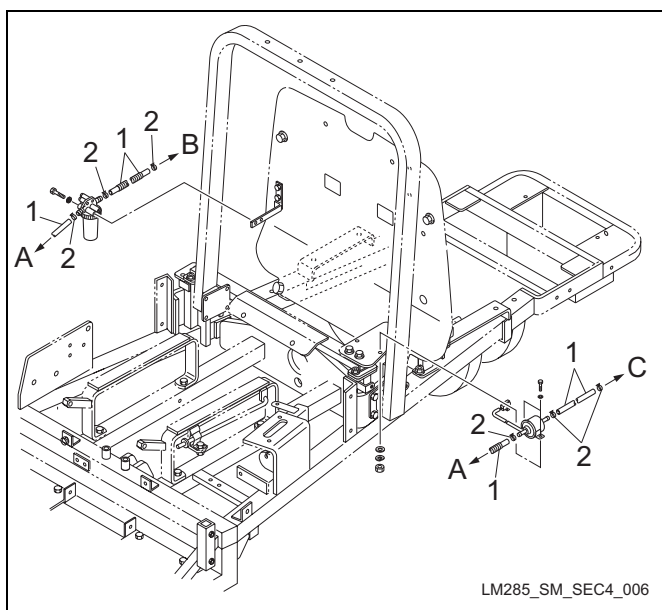

Figure: Engine-6-a

1	Fuel pipe
2	Tightening band

Engine oil

Recommended oil

Do not use special additives.

Use oil classified as CF grade or better if the oil is Kubota genuine oil. Use D10W30 super CF (for all seasons) below 15 deg C and D30 super CF or D10W30 super CF at 15 def C and above.

Important

Do not mix different kinds of engine oil.

Use oil classified as API Service Grade CF or better with SAE viscosity according to your ambient temperature. The amount of engine oil is 3.1 L (0.82 U.S.gals).

Inspection of and refilling the engine oil

1. Keep the engine horizontal and fully insert the oil level gauge (1) to check the amount of oil. The amount is appropriate if the gauge indicates between the upper limit (2) and the lower limit (3).

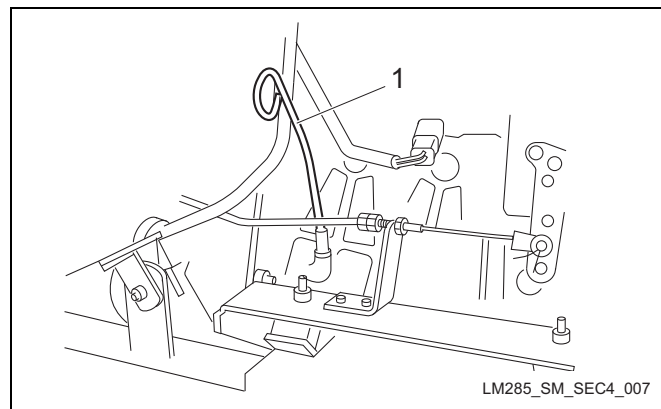

Figure: Engine-7-a

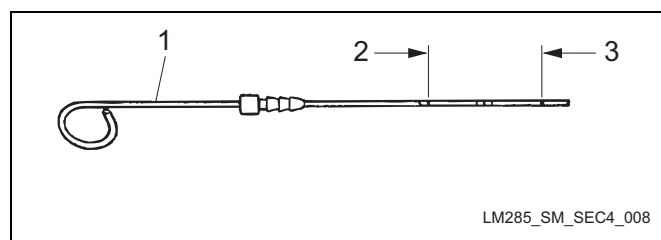

Figure: Engine-8-a

1	Oil level gauge
2	Upper limit
3	Lower limit

2. Refill if the oil is low, and change if it is dirty.
3. Inspect the oil level 10 to 20 minutes after the engine has stopped. Take care to avoid having excess engine oil which may damage or cause problems with the engine.
4. Refill the engine oil through the oil filler cap (1).

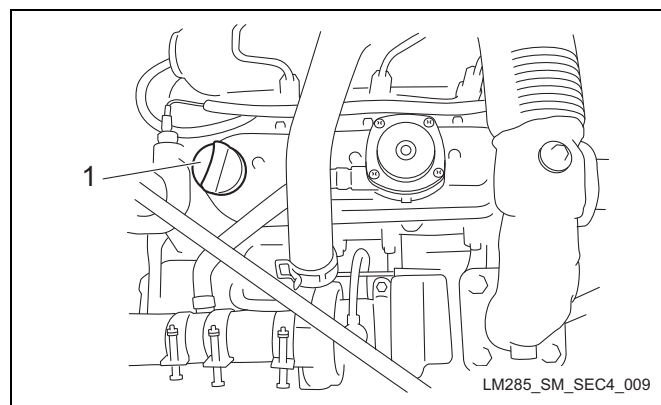

Figure: Engine-9-a

1	Oil filler cap
---	----------------

Engine

- It takes some time for the refilled engine oil to go down to the oil pan.
- Recheck the amount of oil 10 to 20 minutes after you have refilled the oil.

Change of the engine oil

Change of the engine oil

First time	After 50 hours of operation
From the second time onward	Every 100 hours of operation

Change of the oil filter

First time	After 50 hours of operation
From the second time onward	Every 100 hours of operation

Amount of the engine oil

For oil change only	3.1 L (0.82 U.S.gals)
When changing together with the filter	3.1 L (0.82 U.S.gals)

Viscosity of the engine oil

Normal (outside air temperature of 15 deg C or above)	SAE30、SAE10W-30
Winter season (outside air temperature of below 15 deg C)	SAE10W-30

Grade of the engine oil

API Service Grade CF or higher quality for a diesel engine

Warning

When changing engine oil, drain into a container and discard it according to local laws and regulations.

Caution

Take care to avoid hot oil touching your skin, which may cause burns.

Always check the amount of engine oil (oil surface) to ensure it is between the upper limit and the lower limit of the oil level gauge as specified.

Securely screw in the cap of the oil level gauge and oil filler hole. Insufficiently screwing of the cap or a defective seal will fail to maintain negative pressure in the crankcase, which may raise the oil level and result in the emission of white smoke or break the engine.

Inspect the oil level regularly. Change after first 50 hours of operation and for every 100 hours of operation thereafter. Increase the frequency of oil change if the engine oil gets dirty, or the engine is operated in a dusty environment, worked hard or operated at high temperature. Also change the oil filter after first 50 hours of operation and for every 100 hours of operation thereafter.

- Move the machine to a level surface, stop the engine, remove the drain plug (1) while the engine oil is still warm, and drain the engine oil into a container.

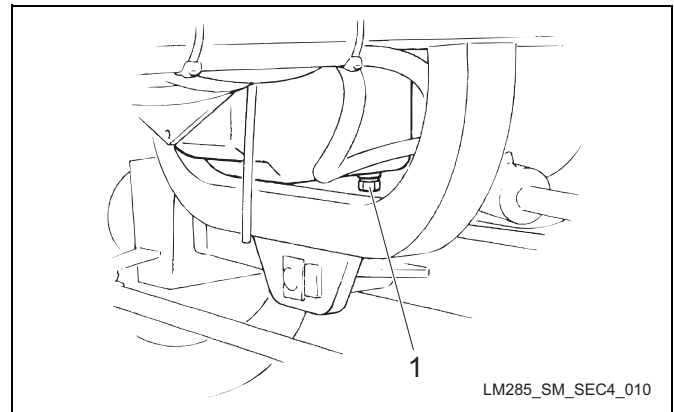

Figure: Engine-10-a

1 Drain plug

- Fit the drain plug (1) and pull out the oil level gauge (1). Fully insert the oil level gauge (1) to check the amount of oil.

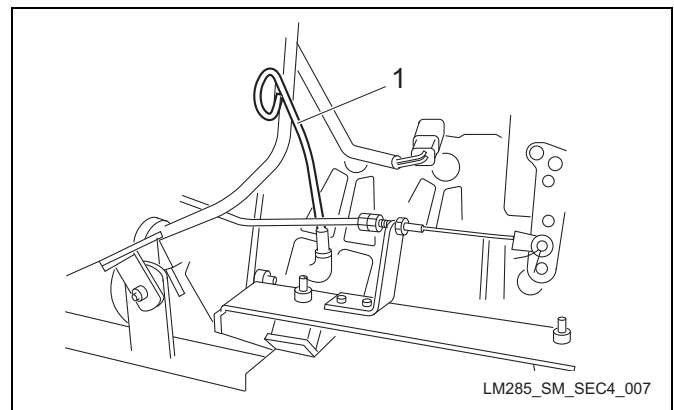

Figure: Engine-11-a

1 Oil level gauge

3. Feed the new engine oil through the oil filler (1) until the oil surface comes between the upper and lower limits of the oil level gauge.

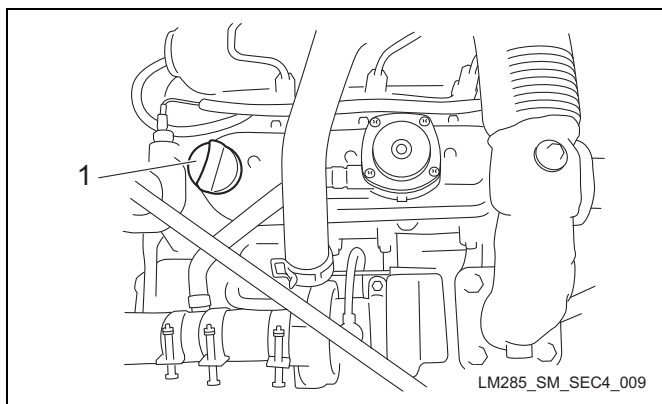

Figure: Engine-12-a

1	Oil filler cap
---	----------------

4. Replace the cap of the oil filler.

Engine oil filter

Change of the engine oil filter

⚠ Caution

Take care to avoid hot oil touching your skin, which may cause burns.

1. Remove the old oil filter (1).
2. Lubricate the gasket of the new oil filter (1) lightly with engine oil, and screw in the oil filter until the gasket touches the adaptor. Tighten for a further 1/2 to 3/4 turn from there with a wrench.

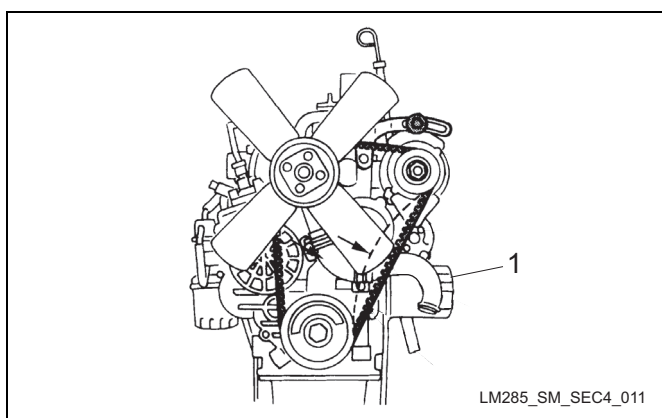

Figure: Engine-13-a

1	Oil filter
---	------------

3. Pull out the oil level gauge (1) and feed new proper oil (recommended oil) little by little. When checking the oil level, screw in the oil level gauge until it reaches the bottom and then remove to check. Start the engine and check for any oil leakage.

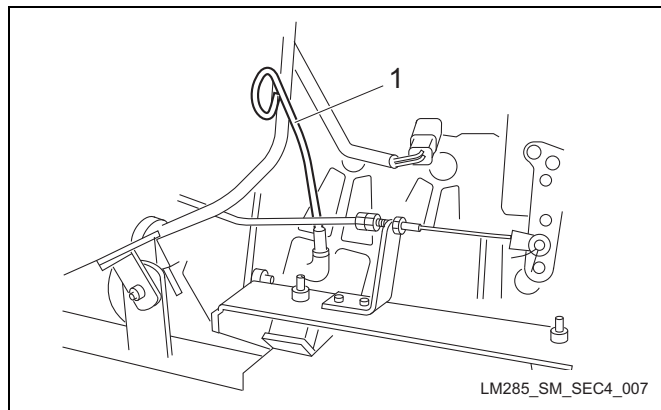

Figure: Engine-14-a

1	Oil level gauge
---	-----------------

Radiator

Change of the coolant water

⚠ Warning

When changing coolant water, drain into a container and discard it according to local laws and regulations.

⚠ Warning

Do not touch the radiator and the coolant water during the engine operation or shortly after the engine stop. High temperature of those may cause burns. Open the radiator cap after the radiator cools down adequately.

1. Remove the radiator cap (1).

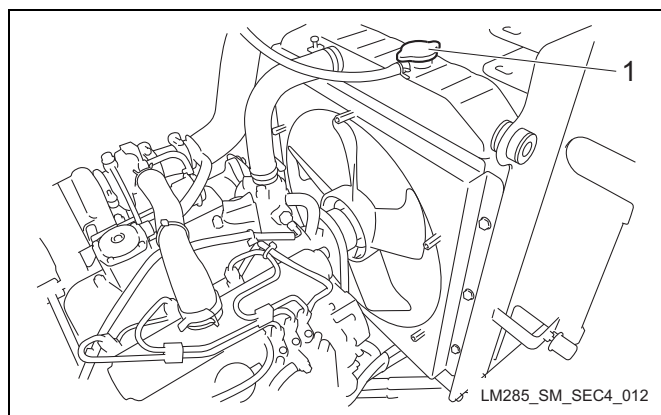

Figure: Engine-15-a

Engine

1	Radiator cap
---	--------------

- Open the drainage cock (1) in the lower portion of the radiator and drain water into a container (2).

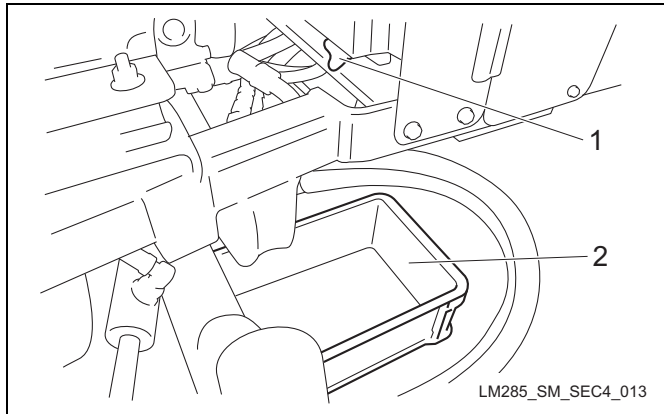

Figure: Engine-16-a

1	Drainage cock
2	Container

- Discharge the coolant water in the reserve tank and clean the inside of the tank.

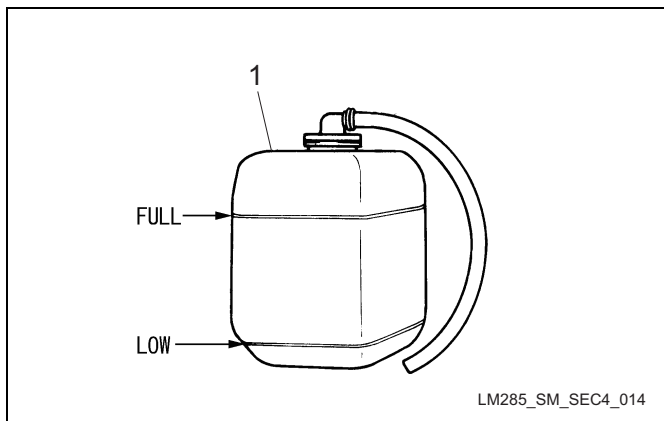

Figure: Engine-17-a

1	Reserve tank
---	--------------

- Make mixed liquid of antifreeze and pure water in a container like a bucket in consideration of the coolant water amount and freezing temperature and stir it well.
- Close the drainage cock and feed the mixed liquid through the radiator feed-water inlet up to the inlet level. Feed it also into the reserve tank so that the level will be between FULL and LOW. The amount of the coolant water should be 6 L (1.6 U.S. gals) including the reserve tank.
- Operate the engine for about 10 minutes to circulate it and bleed air.

- Refill the mixed liquid so that the level of the coolant water in the reserve tank will be between FULL and LOW.

⚠ Caution

Coolant water may vary depending on the specifications.

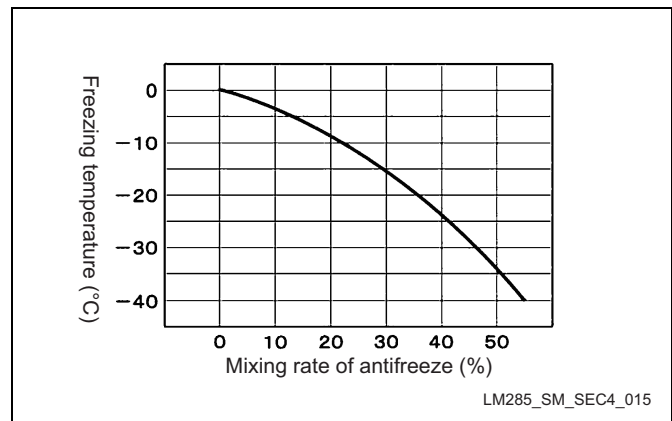

Figure: Engine-18-a

Removal and installation of each section

Engine

Removal of the engine

- Remove the minus plug of the battery.
- Remove the rear cover. (Refer to “Removal of rear cover” (Page 7-18))

- Remove the bolts (1), S washers (2) and washers (3) and then remove the side cover right (4) and the side cover left (5) together with the stays (6).

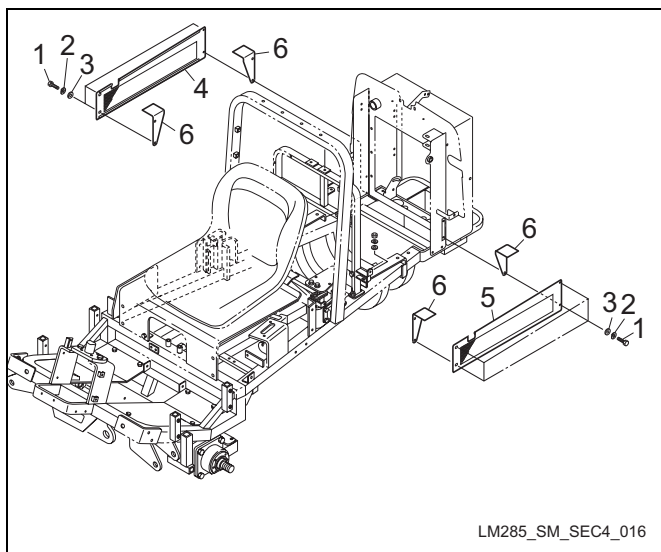

Figure: Engine-19-a

1	Bolt
2	S washer
3	Washer
4	Side cover right
5	Side cover left
6	Stay

- Remove the radiator. (Refer to “Removal of the radiator” (Page 4-13))
- Remove the split pin (2) from the speed adjustment lever (1) of the engine and then remove the washer (3) and the flat head pin (4) and then remove the throttle wire (5).

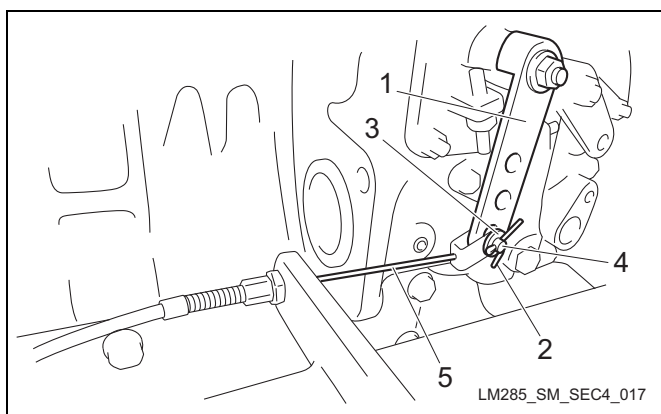

Figure: Engine-20-a

1	Speed adjustment lever
2	Split pin
3	Washer
4	Flat head pin
5	Throttle wire

Important

Exercise care not to let the removed parts enter the inside of the engine.

- Remove the four nuts (1) and then remove the muffler together with the exhaust flexible pipe (2).

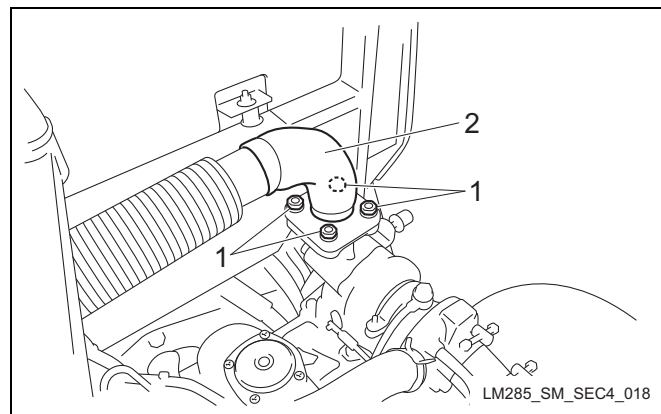

Figure: Engine-21-a

1	Nut
2	Exhaust flexible pipe

- Remove the wiring from the rotation sensor (1), the water temperature sensor for buzzer (2), the sensor for water temperature gauge (3) and the stop solenoid (4).

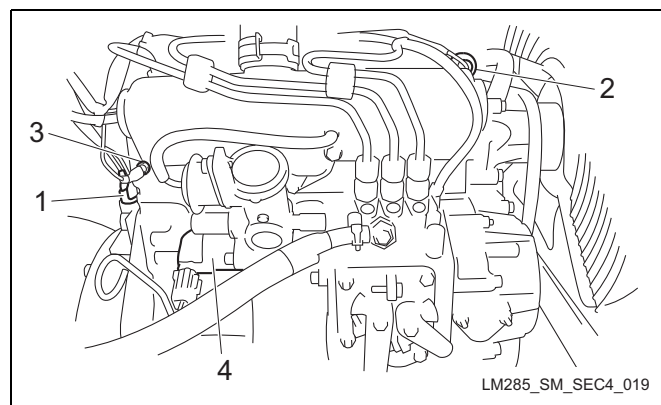

Figure: Engine-22-a

1	Rotation sensor
2	Water temperature sensor for buzzer
3	Sensor for water temperature gauge
4	Stop solenoid

Engine

8. Remove the earth wire (1).

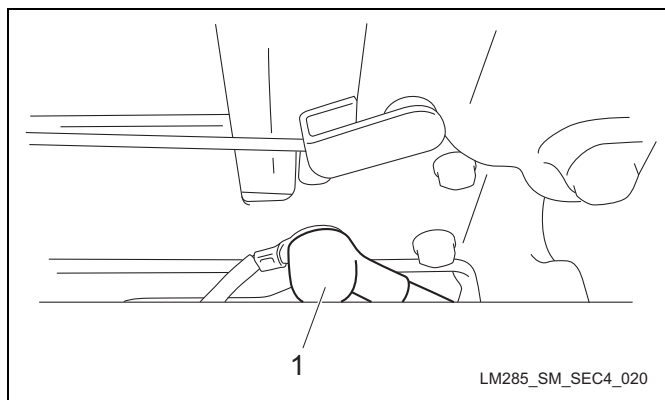

Figure: Engine-23-a

1	Earth wire
---	------------

9. Remove the glow wiring (1).

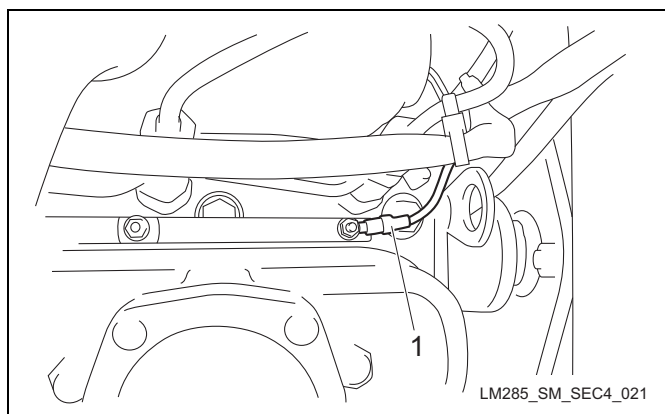

Figure: Engine-24-a

1	Glow wiring
---	-------------

10. Remove the alternator wiring (1), the starter wiring (2) and the hydraulic switch wiring (3).

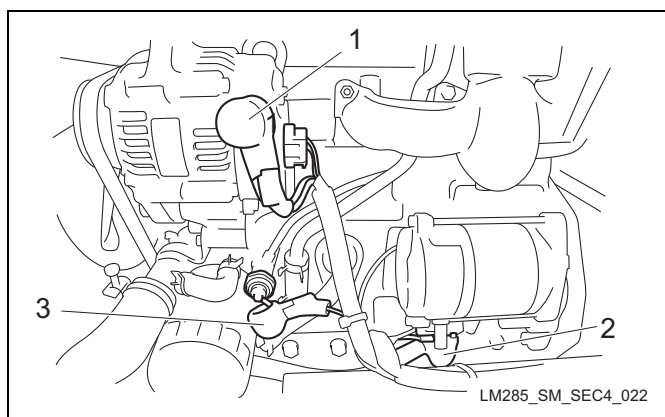

Figure: Engine-25-a

1	Alternator wiring
2	Starter wiring
3	Hydraulic switch wiring

11. Plug the fuel tube (1) to avoid fuel leakage.

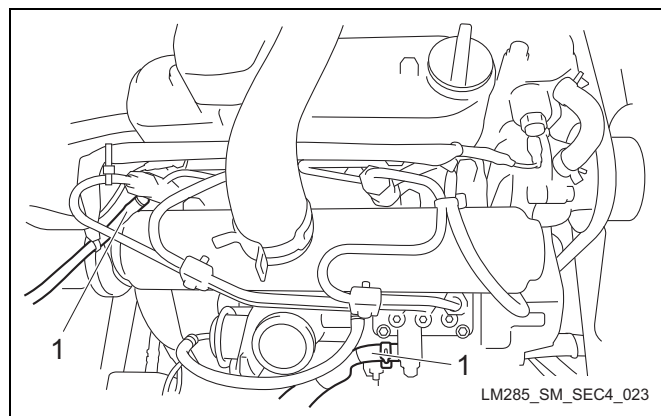

Figure: Engine-26-a

1	Fuel tube
---	-----------

12. Remove the bolts (1) and the nut (2) and then remove the torque rod (3).

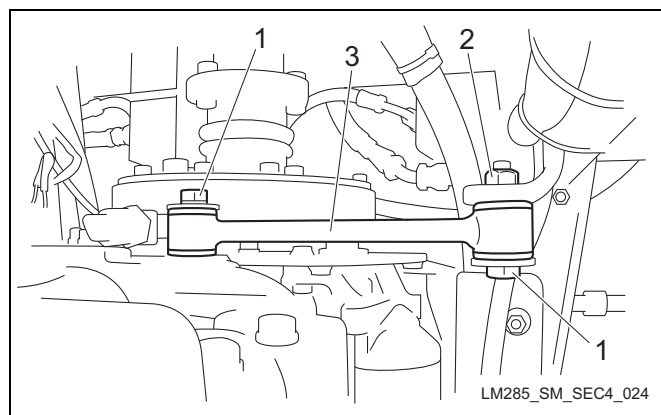

Figure: Engine-27-a

1	Bolt
2	Nut
3	Torque rod

13. Remove the bolts (1), the S washers (2) and the washers (3) and detach the joint mounting bracket (5) from the flywheel (4).

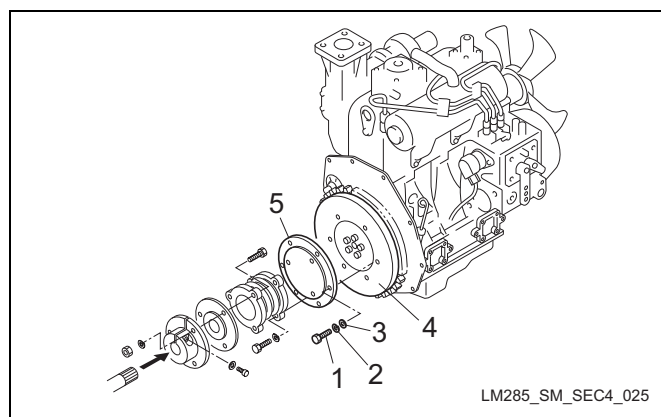

Figure: Engine-28-a

1	Bolt
2	S washer
3	Washer
4	Flywheel
5	Joint mounting bracket

- Remove the nuts (3) fastening the right and left engine bases (1) and the antivibration rubbers (2).

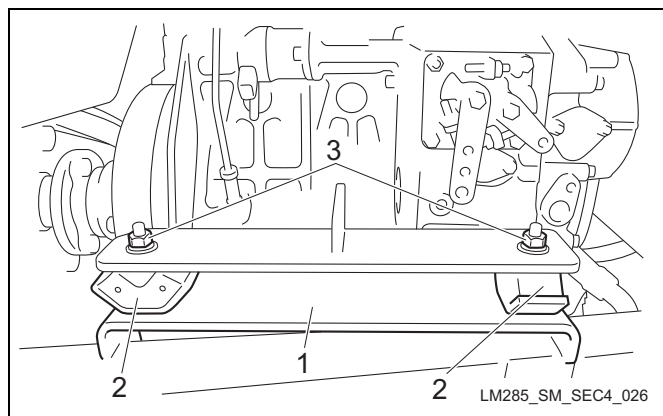

Figure: Engine-29-a

1	Engine base
2	Antivibration rubber
3	Nut

Important

Use adequately strong hooks and lifting brackets.

Important

Confirm that the wiring, hoses etc. are removed from the engine.

- Hook the lifting brackets (1) of the engine with the hooks (2) and lift the engine (3) to remove it.

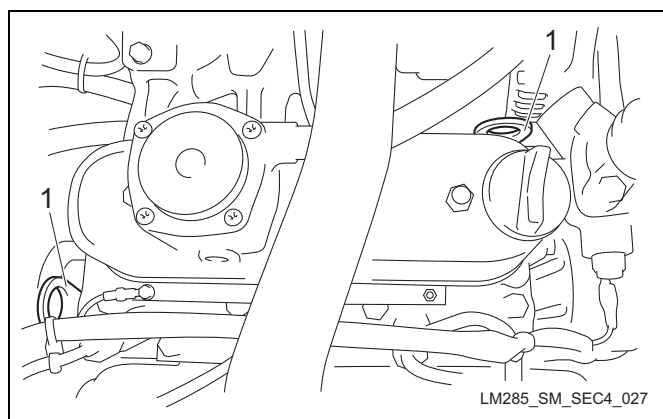

Figure: Engine-30-a

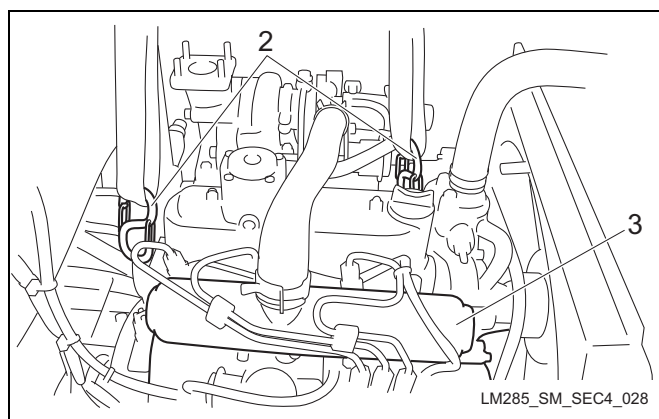

Figure: Engine-31-a

1	Lifting bracket
2	Hook
3	Engine

Installation of the engine

Caution

Refer to the tightening torques list. We are not responsible for failure due to abnormal tightening, excessive torque tightening and so on.

Important

Exercise care not to tuck down the wiring and hoses etc.

For the installation, reverse the removal procedure.

Radiator

Removal of the radiator

Warning

Do not touch the radiator, the coolant water, the engine and the muffler during the engine operation or shortly after the engine stop. High temperature of those may cause burns. Work after they cool down adequately.

- Remove the rear cover. (Refer to “Removal of rear cover” (Page 7-18))

Engine

- Remove the bolts (1) and the S washers (2) and then remove the radiator cover (3).

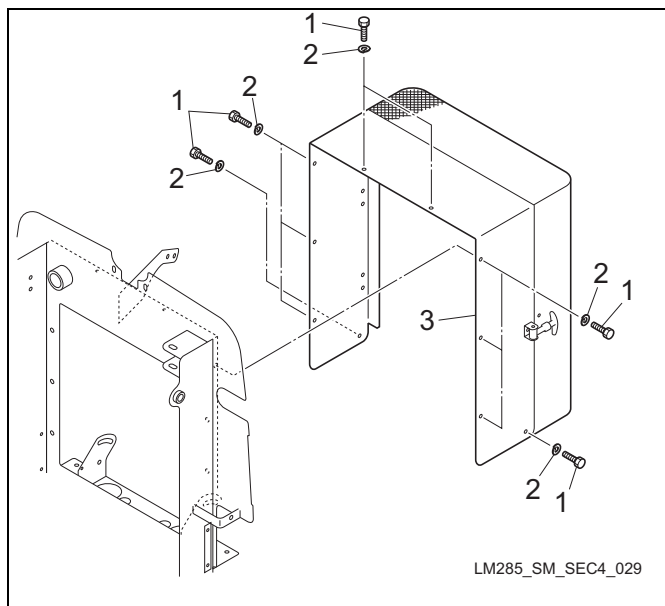

Figure: Engine-32-a

1	Bolt
2	S washer
3	Radiator cover

- Remove the bolts (1), the S washers (2), the washers (3) and the nuts (4) and then remove the bonnet mounting bracket (5).

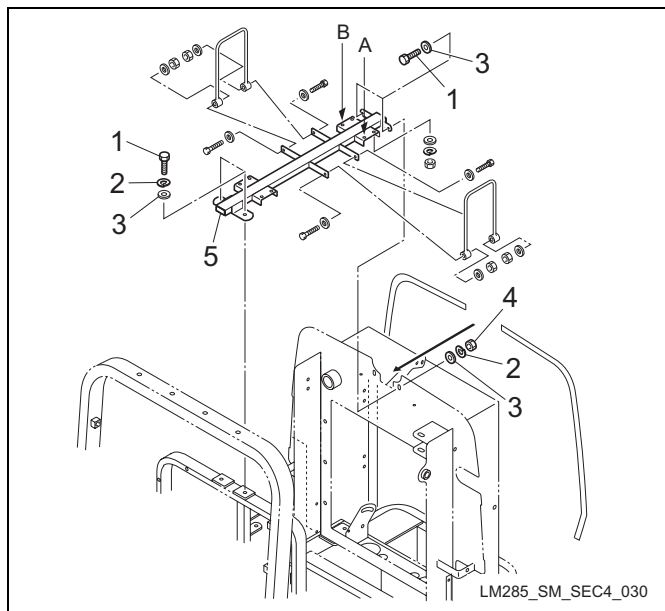

Figure: Engine-33-a

1	Bolt
2	S washer
3	Washer
4	Nut
5	Bonnet mounting bracket

- Remove the nuts (1), the S washers (2), the washers (3) and the bolts (4) and then remove the support bar (5).

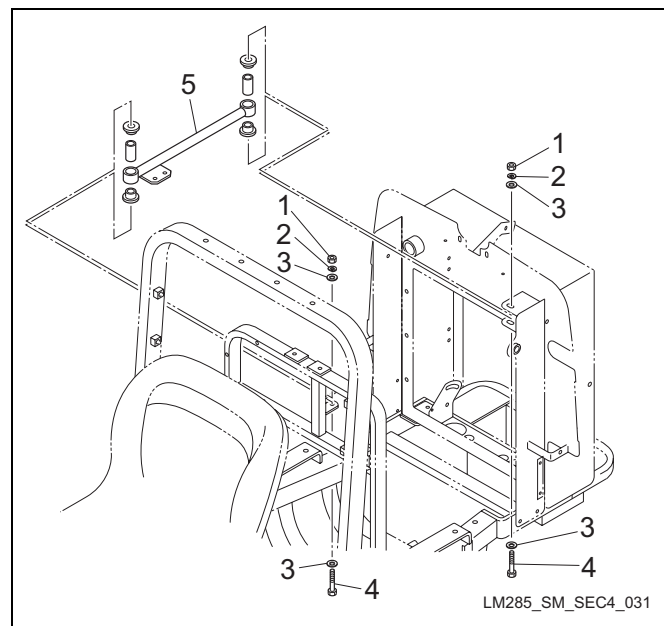

Figure: Engine-34-a

1	Nut
2	S washer
3	Washer
4	Bolt
5	Support bar

- Remove the nuts (1), the S washers (2), the washers (3) and the bolts (4) and remove the tail-pipe (5).

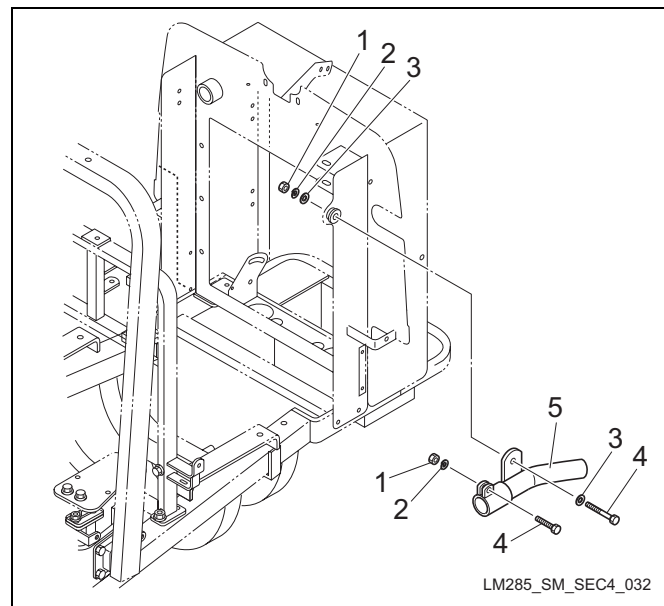

Figure: Engine-35-a

1	Nut
2	S washer
3	Washer
4	Bolt
5	Tail-pipe

6. Remove the bolts (1) and then remove the fan cover (2) and the shroud (3).

Warning

Do not touch the radiator and the coolant water during the engine operation or shortly after the engine stop. High temperature of those may cause burns. Open the radiator cap after the radiator cools down adequately.

7. Remove the radiator cap (4).

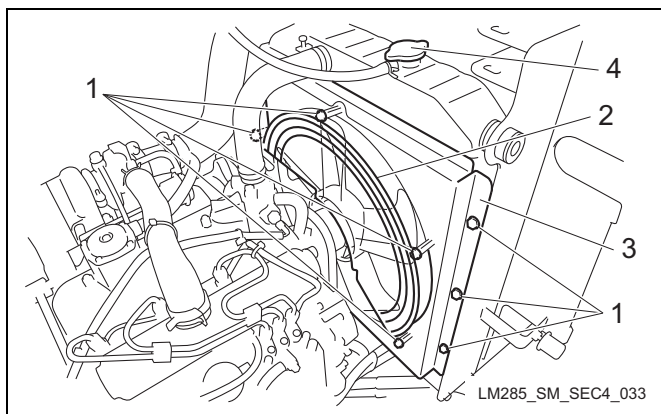

Figure: Engine-36-a

1	Bolt
2	Fan cover
3	Shroud
4	Radiator cap

Warning

When changing coolant water, drain into a container and discard it according to local laws and regulations.

8. Open the drainage cock (1) in the lower portion of the radiator and drain water into a container (2). After drainage, close the drainage cock and attach the radiator cap.

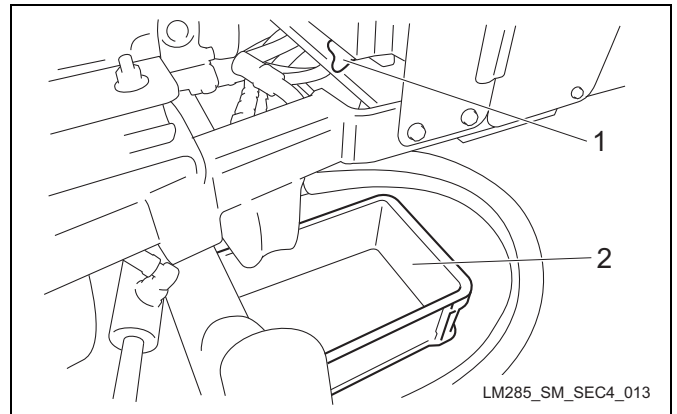

Figure: Engine-37-a

1	Drainage cock
2	Container

9. Loosen the hose band and remove the banner hose (1), the water hose upper (2), the water hose lower (3) and the overflow pipe (4) from the radiator.

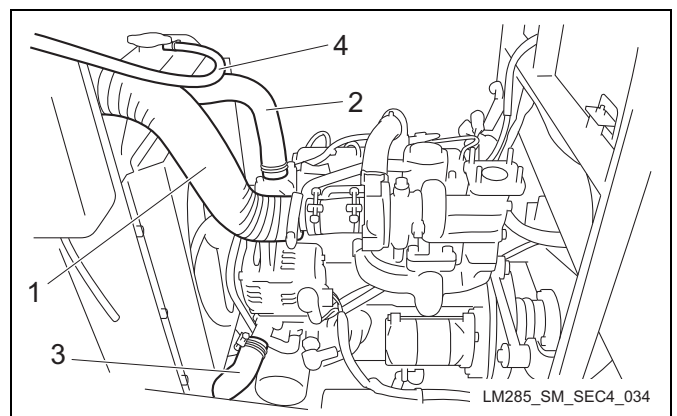

Figure: Engine-38-a

1	Banner hose
2	Water hose upper
3	Water hose lower
4	Overflow pipe

Engine

- Remove the bolts (3) fastening the radiator (1) and the radiator mounting bracket (2).

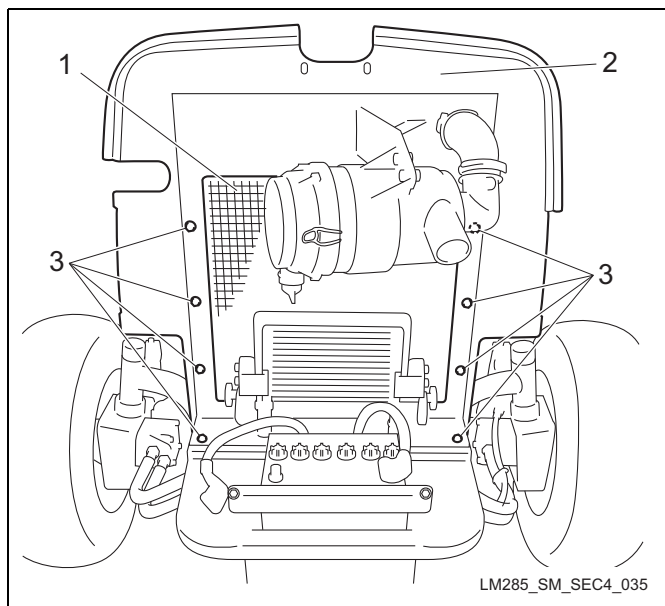

Figure: Engine-39-a

1	Radiator
2	Radiator mounting bracket
3	Bolt

- Tilt the radiator mounting bracket (1) backward and remove the radiator (2).

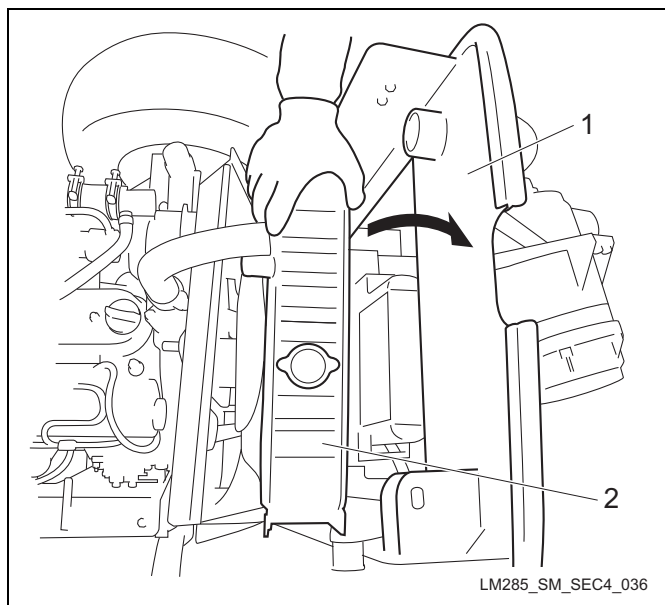

Figure: Engine-40-a

1	Radiator mounting bracket
2	Radiator

Installation of the radiator

Caution

Refer to the tightening torques list. We are not responsible for failure due to abnormal tightening, excessive torque tightening and so on.

Important

Refill coolant water. (Refer to the owner's manual of the engine.)

For the installation, reverse the removal procedure.

Maintenance	5-2	4-block valve	5-48
Specifications	5-3	Gear motor	5-50
Adjusted value	5-3	Raise/lower cylinder	5-51
Hydraulic equipment layout	5-4	Selector valve	5-53
Flow of hydraulic oil	5-6	Steering cylinder	5-57
General instructions	5-8	Oil cooler	5-58
Hydraulic hose	5-8	Manifold with emergency relief valve	5-58
Hydraulic fitting	5-9	Wheel motor	5-60
Towing	5-12	Manifold with solenoid valve	5-62
Neutral	5-12	Orbitrol	5-63
Depressurization	5-12	Hydraulic tank	5-64
Hydraulic circuit failure	5-12		
Hydraulic circuit flow	5-13		
Traveling circuit	5-13		
Raising/lowering circuit	5-15		
Steering circuit	5-17		
Reel rotation circuit	5-19		
Special tools	5-21		
Measurement method	5-23		
Note	5-23		
Traveling circuit	5-24		
Raising/lowering circuit	5-32		
Steering circuit	5-34		
Charge circuit	5-36		
Reel rotation circuit	5-38		
Adjustment	5-39		
Selector valve	5-39		
General inspection and repair	5-40		
Note	5-40		
Hydraulic hose, piping	5-40		
Hydraulic oil	5-40		
Bleeding	5-41		
Inspection and repair of each section	5-42		
Hydraulic oil	5-42		
Hydraulic oil filter	5-43		
Selector valve	5-44		
Removal and installation of each section	5-44		
Piston pump	5-44		

Hydraulic system

Maintenance

This chapter describes the main inspection and maintenance methods of the LM285 hydraulic system. Refer to the LM285 Owner's manual and parts catalog for daily inspection, maintenance and handling of this machine.

In addition, hydraulic equipment cannot basically be disassembled for maintenance with a view to maintaining performance. For components specified for repair by manufacturers, procedures for disassembly and maintenance are not described. Contact either the dealer or us for repair. Note that disassembly and maintenance may constitute a waiver of product warranty.

Danger

Follow the instructions below for safe inspection and maintenance.

1. Move the equipment to a level surface to prepare for adjustment and maintenance. Apply the parking brake, stop the engine and remove the key. Make sure that each part has completely stopped its motion before starting procedures for adjustment, maintenance and so on.
2. Keep away from moving parts. Avoid adjustment as much as possible with the engine running. Keep people away from the area.
3. Use an appropriate chain block, hoist and jack as needed. Securely support the lifted machine with a jack stand or an appropriate block.
4. Use BARONESS genuine parts for replacement and accessories.
5. Never start the engine in an enclosed room, or poisoning by carbon monoxide may occur.
6. Never touch the exhaust system while the engine is running or right after the engine has stopped. Its high temperature may cause a burn.
7. Keep flames away from the battery. Batteries emit hydrogen gas, and mishandling may ignite it and cause an explosion.
8. The electrolytic solution in the battery is sulfuric acid. Contact with the electrolytic solution (sulfuric acid) may cause blindness or a burn. Also, if it comes into contact with the vehicle, it may damage it.

Specifications

Adjusted value

Selector valve cam	Motors stop at the height of more than 400mm (15.75in) from the ground to the outer end of #4 and 5 mower units..	#4 and 5 mower arm fulcrums
--------------------	-------------------------------------------------------------------------------------------------------------------	-----------------------------

Adjustment of the selector valve cam

Refer to “Adjustment” (Page 5-39) for adjustment method.

HST Piston pump Displacement High-pressure relief set pressure Charge relief set pressure Gear pump (Charge) Displacement Gear pump (Mower) Displacement	DAIKIN PV-1616AR 0 – 23.0 cm ³ /rev (0 – 1.40 in ³ /rev) 20.6 MPa (2,987.67 psi) 0.4 – 0.5 MPa (58.01 – 72.51 psi) 14 cm ³ /rev (0.85 in ³ /rev) 11 cm ³ /rev (0.67 in ³ /rev)
Wheel motor Front wheel motor Displacement Rear wheel motor Displacement	EATON orbit motor 2-200BS4S 195 cm ³ /rev (11.90 in ³ /rev) 2-200BS4S 195 cm ³ /rev (11.90 in ³ /rev)
Reel motor MB4AK379(STD) displacement MB6AK379(OP) displacement	EATON MB gear motor 16.0 cm ³ /rev (0.98 in ³ /rev) 22.2 cm ³ /rev (13.55 in ³ /rev)
Steering control unit Orbitrol Displacement Relief set pressure Flow divider Prior flow	USB070A08GCD with EATON VD5XMED UBS070A08GCD 69.0 cm ³ /rev (4.21 in ³ /rev) 6.9 MPa (1,000.73 psi) VD5XMED 7 L/min (1.85 US gallons/min)
4-block valve Relief set pressure Prior flow	SANYO ASV50 13.7 MPa (1,986.95 psi) 6 L/min (1.59 US gallons/min)
Relief valve Relief set pressure	SANYO BRV15 17.2 MPa (2,494.56 psi)
Hydraulic tank capacity (Oil gauge center)	24 L (3.34 US gallons)
Hydraulic line filter (Cartridge type)	10 μm
Hydraulic oil	Equivalent of Shell Tellus 46 (ISO VG46)

Hydraulic system

Hydraulic equipment layout

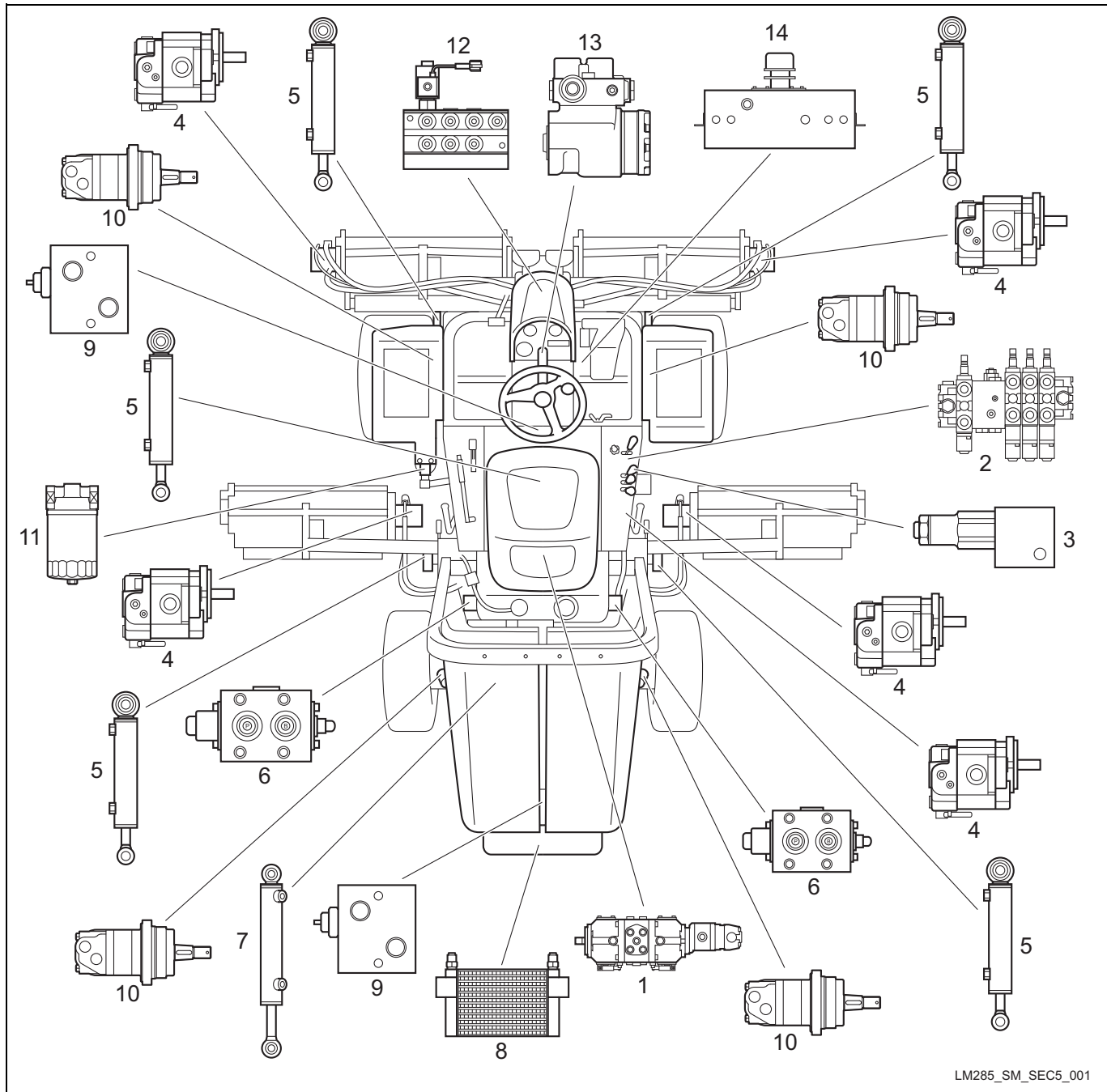

Figure: Hydraulic system-1-a

1	Piston pump
2	4-block valve
3	Relief valve
4	Gear motor (#1 to 5)
5	Raise/lower cylinder (#1 to 5)
6	Selector valve
7	Steering cylinder
8	Oil cooler
9	Manifold with emergency relief valve
10	Wheel motor
11	Hydraulic filter

12	Manifold with solenoid valve (Valve module)
13	Orbitrol
14	Hydraulic tank

1. **Piston pump**

This is to convert mechanical energy of the motor to fluid energy through reciprocal movement of the piston. It is positioned in front of the engine and at the center of main body.
2. **4-block valve**

It combines three valves for reel unit raising/lowering with a valve for reel motor rotation and is positioned within arm's reach on the right side of the seat.
3. **Relief valve**

It is installed in 4-block valve. To protect the mechanism, it automatically opens and lets off the fluid when the pressure comes up to a certain level and it closes when the pressure is reduced.
4. **Gear motor**

This is to convert fluid energy from the pump to mechanical energy (rotational movement) with two gears in order to rotate a reel cutter. It is positioned in each reel unit.
5. **Raise/lower cylinder**

This is to convert fluid energy from the pump to mechanical energy (reciprocal movement) for raising/lowering of the mower unit. It is positioned in the arm of each reel unit.
6. **Selector valve**

It switches between rotation and stop of the gear motor by switching the direction of fluid flow. It is positioned inside of #4 and 5 reel units.
7. **Steering cylinder**

The control valve, which works directly with the steering, controls the flow direction of oil from the hydraulic pump for turning left and right. The steering cylinder is positioned between the rear tires.
8. **Oil cooler**

This is to cool high temperature oil. It is positioned at the end of the main body, behind the engine.
9. **Manifold with emergency relief valve**

It has oil pathways inside and connecting ports outside. It enables tow by opening the relief valve when a trouble develops. They are positioned in front of and below the seat and between the rear tires.
10. **Wheel motor**

This is to convert fluid energy from the pump to mechanical energy (rotational movement) and directly drive the vehicle body. They are positioned at each wheel.
11. **Hydraulic filter**

It removes dirt and dust etc. from the fluid. Without this important filter, a big trouble may develop. It is positioned behind the left hand footstep.
12. **Manifold with solenoid valve**

It has oil pathways inside and connecting ports outside. It operates rotation and stop of reel cutters. It is positioned at the center under the front cover.
13. **Orbitrol**

It is a power-steering unit for all hydraulic system, which switches internal valves by rotary input of steering wheel and sends oil from the hydraulic pump to the steering cylinder. It is positioned at the center under the front cover.
14. **Hydraulic tank**

It stores extra hydraulic oil and reduces its temperature. It is positioned between the seat and the steering wheel and under them.

Hydraulic system

Flow of hydraulic oil

Flow of oil during forward traveling

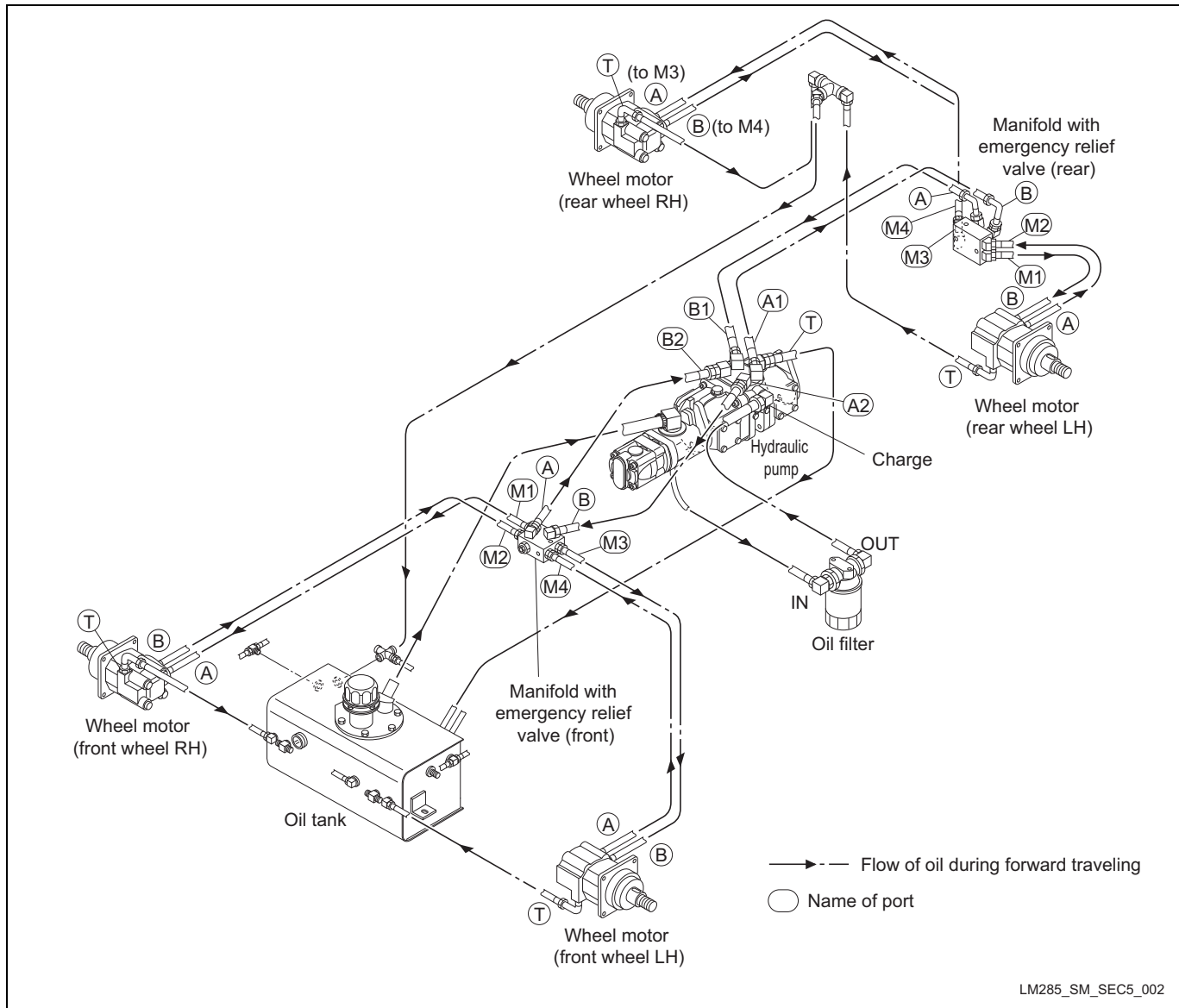

Figure: Hydraulic system-2-a

Hydraulic system

Flow of oil during raising mowers and during counter-clockwise turning by power steering.

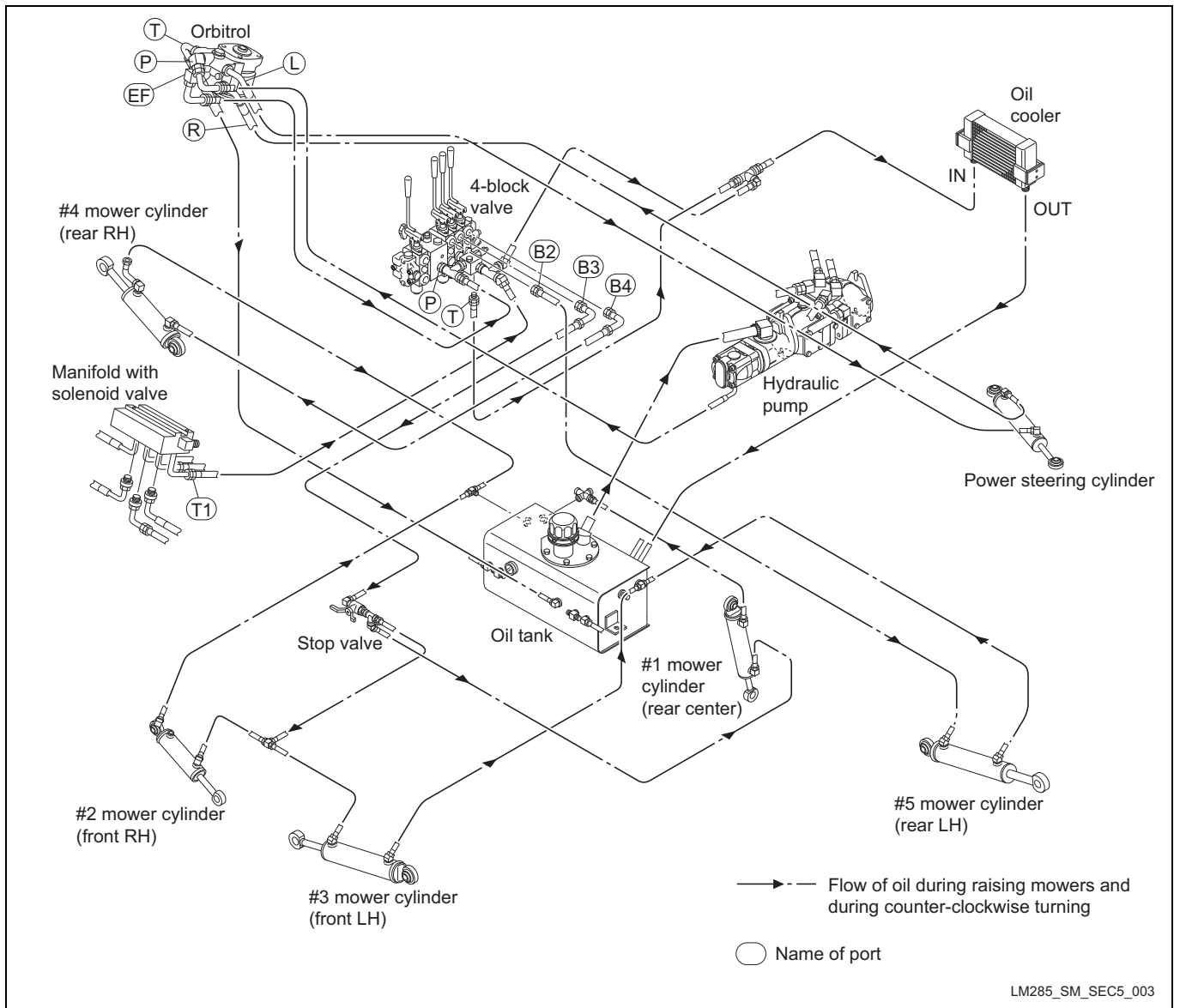

Figure: Hydraulic system-3-a

Hydraulic system

Flow of oil during mowing

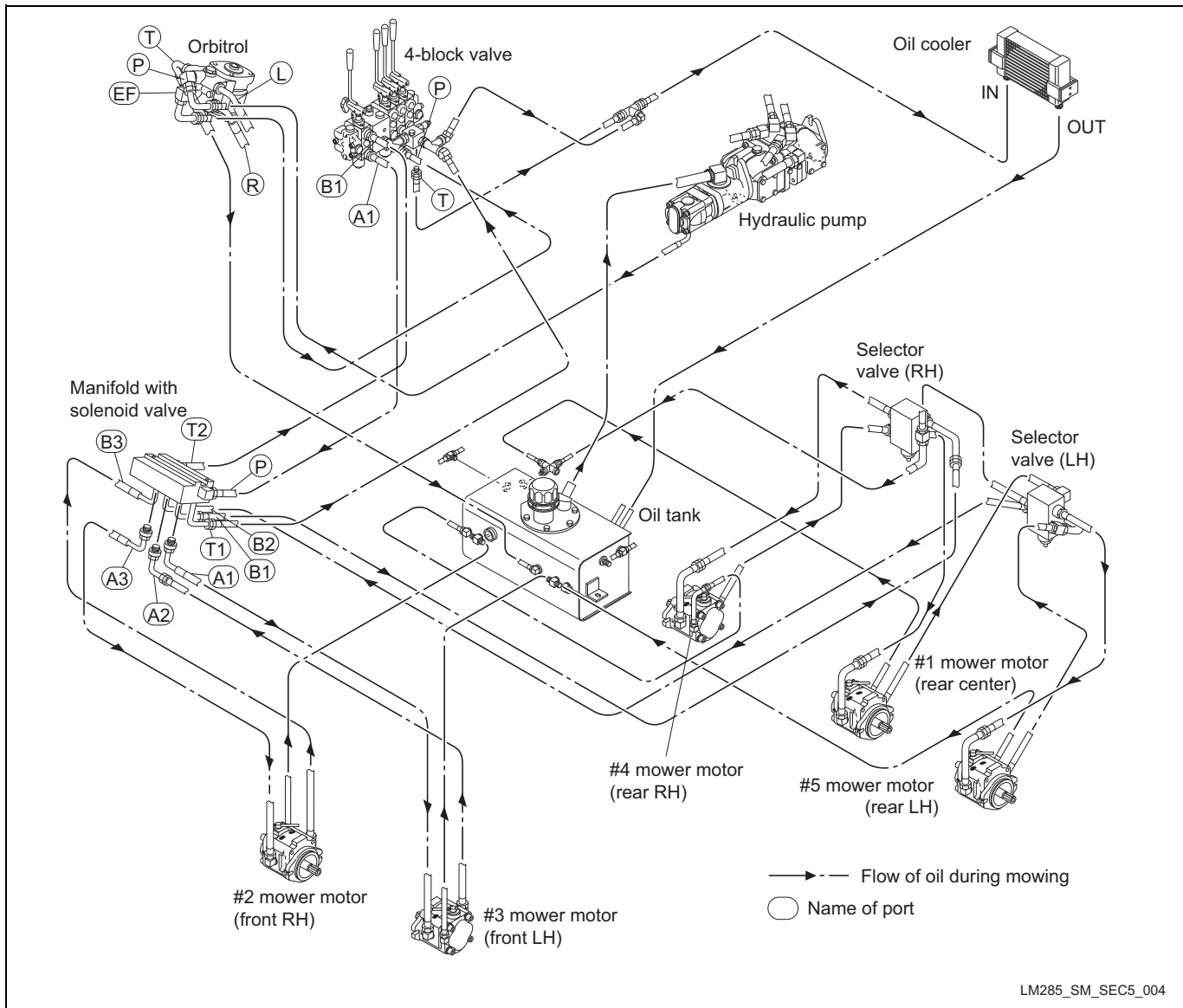

Figure: Hydraulic system-4-a

General instructions

Warning

Be sure to depressurize the hydraulic system before maintaining or repairing it.

Stop the engine, and lower or support the work machine and mower unit.

When checking for pinhole leakage of the hydraulic circuit or oil leakage of the nozzle, search for a leakage point using something like paper or cardboard, never with your bare hands. Be careful about high-pressure oil which may pierce your skin, resulting in physical injury.

Hydraulic hose

Hydraulic hoses are subjected to excessive load when weathered, exposed to the sun or chemicals, stored in a very hot storage environment, or handled roughly during operation or maintenance work. These factors may cause damage to hoses or facilitate their deterioration. Since a hydraulic hose is more sensitive to external conditions than other components, check it frequently for damage, deterioration or the like of.

When replacing the hydraulic hose, check that the hose is straight (not twisted before fitting).

When replacing the hydraulic hose, use two wrenches. First, support the hose at a designated point with the first wrench. Next, fasten the hose swing nut to the fitting with the second wrench.

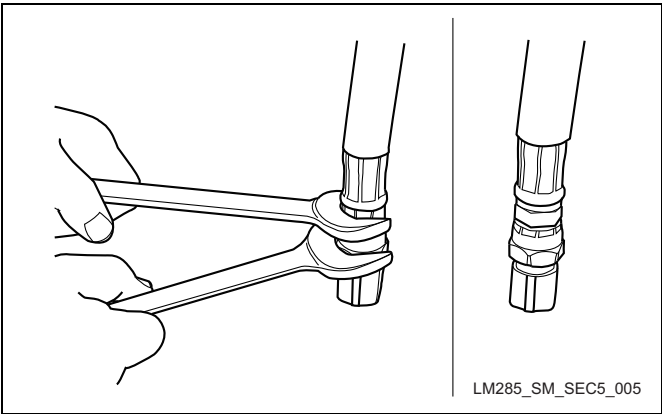

Figure: Hydraulic system-5-a

Hydraulic fitting

Bite type tube fitting

■ Preliminary tightening (Preset)

1. Directly cut the tube at the designated length.

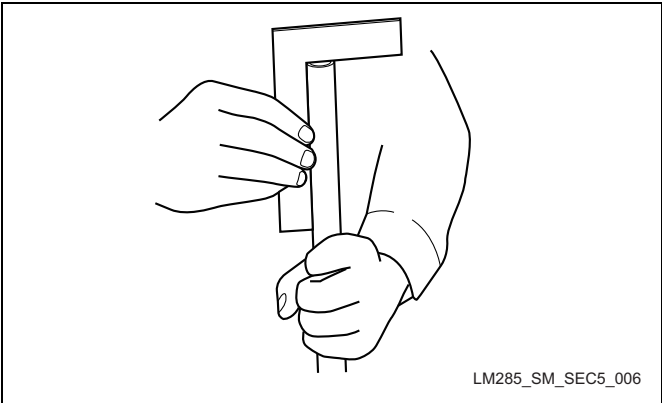

Figure: Hydraulic system-6-a

2. Remove burrs on the inside and outside of the tube with a file or the like of.

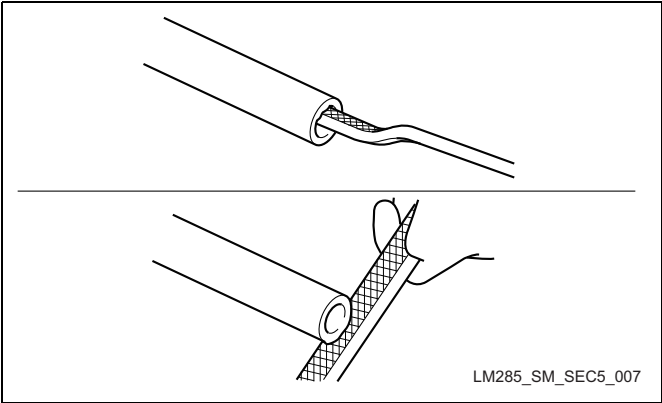

Figure: Hydraulic system-7-a

3. Insert the nut and sleeve into the tube. Note the direction of the sleeve.

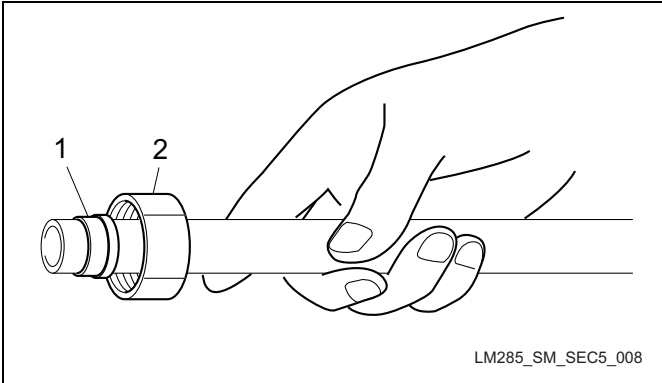

Figure: Hydraulic system-8-a

1	Sleeve
2	Nut

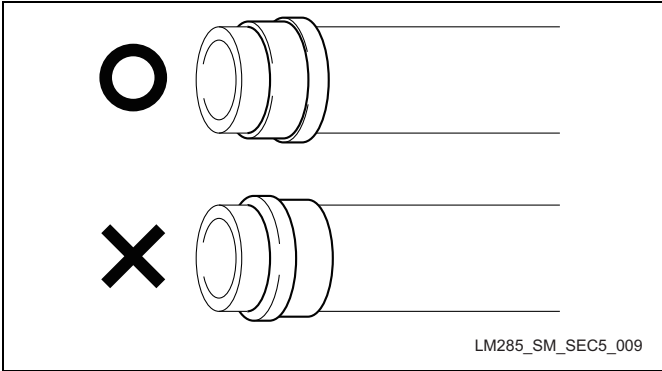

Figure: Hydraulic system-9-a

4. Fix the temporary tightening jig onto the vice and apply hydraulic oil to the threads, tapered part, and sleeve.

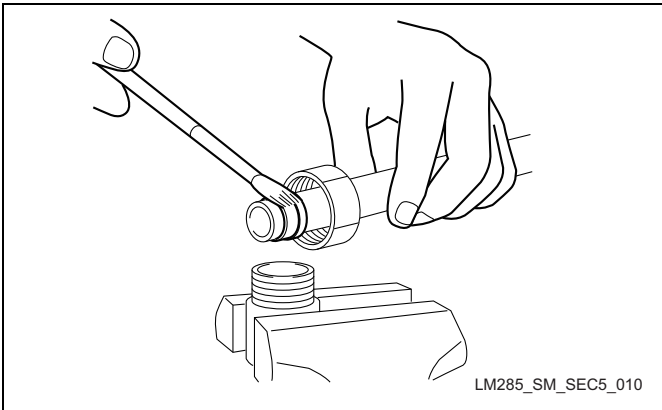

Figure: Hydraulic system-10-a

Hydraulic system

- Put the tube end onto the hole bottom of the temporary tightening jig and tighten the nut slowly to the point where the tube can no longer be rotated by hand. This point is called the “zero point.”

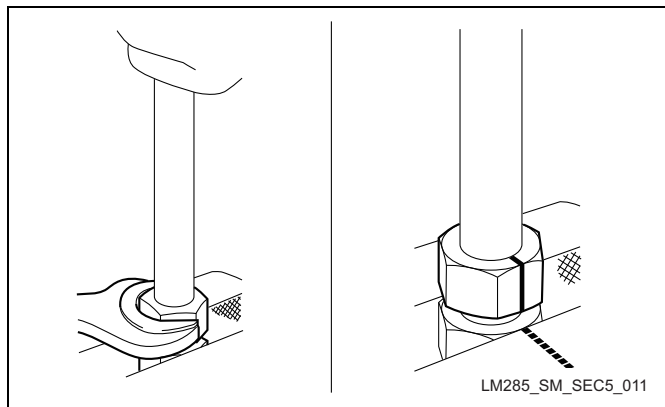

Figure: Hydraulic system-11-a

- Matchmark the zero point and further tightening of 3/4 to one turn will cause the sleeve to bite into the tube.

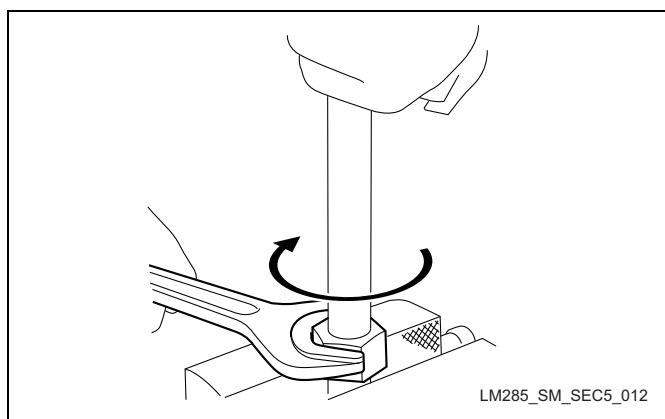

Figure: Hydraulic system-12-a

- Fasten the nut and check that the sleeve end is a few mm apart from the tube end and the sleeve will not move in axial direction (it is allowed to move in the circumferential direction).

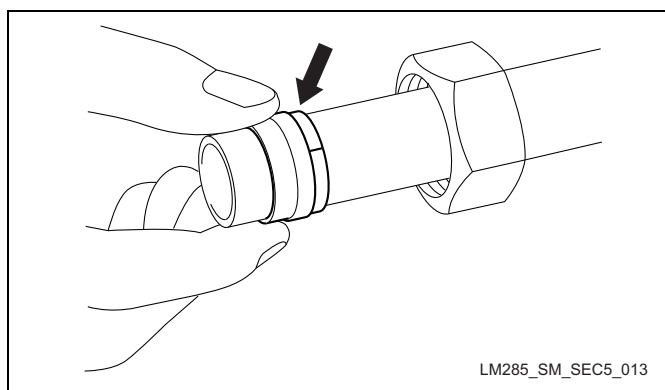

Figure: Hydraulic system-13-a

■ Final tightening (Reset)

Fit the preliminary tightened tube onto the fitting body. Tighten with a spanner to the point where some resistance

is suddenly felt, then further tighten with the nut for a 1/4 turn.

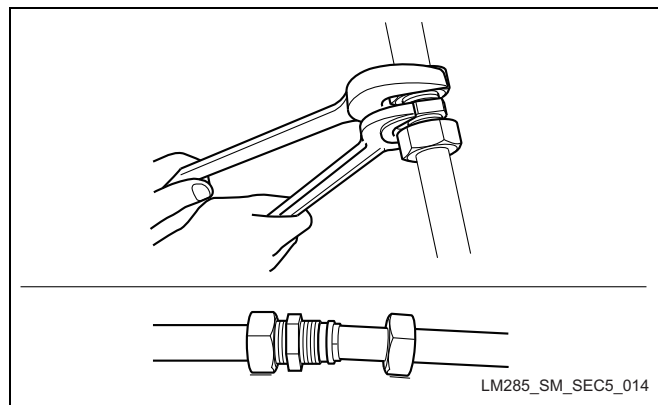

Figure: Hydraulic system-14-a

Reference: Reference: For direct tightening, use the fitting body to follow procedures 1 to 5 when using a temporary tightening jig, and set the zero point. Further tighten for 1/4 to one turn from the zero point.

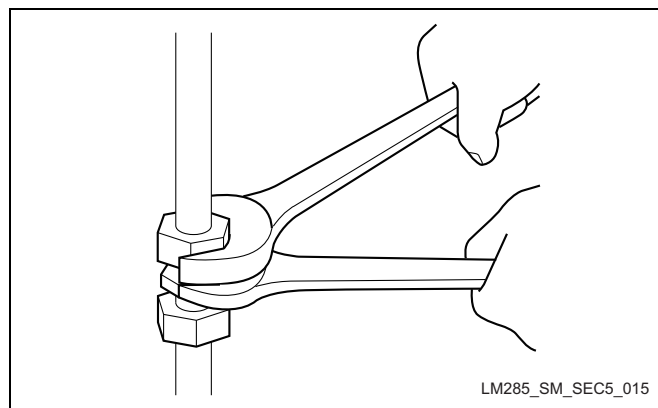

Figure: Hydraulic system-15-a

■ Reuse of piping

Bite type fitting can be reused if an inspection finds no flaw or other damage on the sleeve surface. Done properly, disassembly and retightening can be carried out up to five times or so.

Fitting with parallel pipe threads (O ring sealing system)

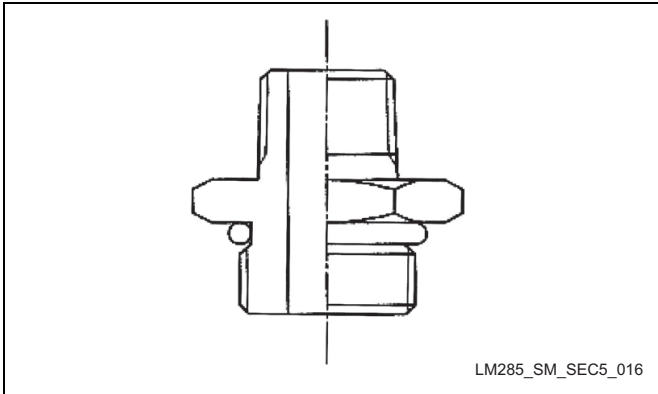

Figure: Hydraulic system-16-a

1. Check to see if the O ring is properly fitted to the groove of the main body.
2. Check to see that the thread part, seat surface of O ring port and O ring are free from flaws or foreign matter.
3. Before fitting, apply hydraulic oil or grease to the O ring.
4. For fitting, screw in by hand till the main body touches the other side lightly, then tighten securely with a tool such as a spanner.

■ Adjustable joint

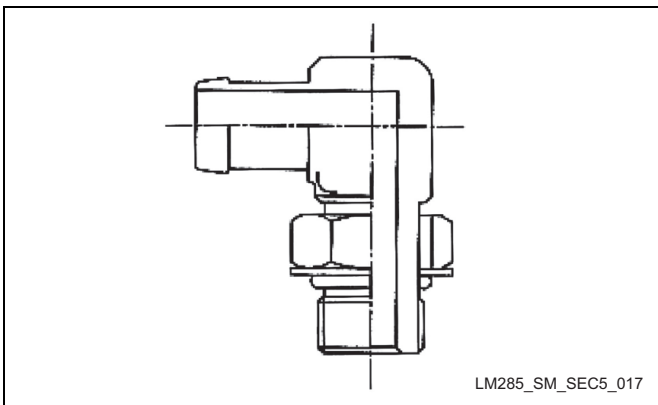

Figure: Hydraulic system-17-a

1. Check to see if the lock nut (2), washer (3), and O ring (4) are in the correct position. The correct position is where the washer is pressed onto the upper end of the groove of the main body (1).

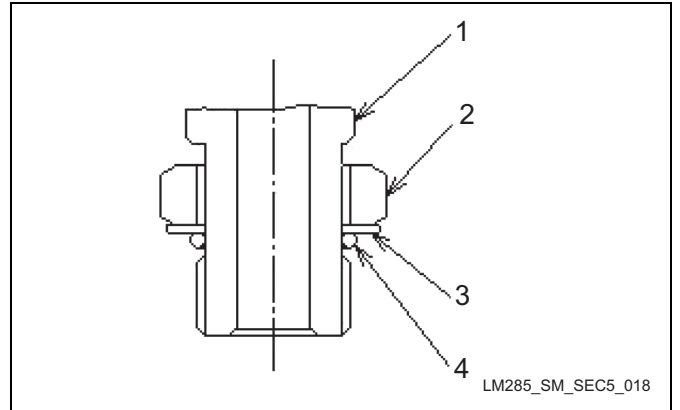

Figure: Hydraulic system-18-a

1	Main body
2	Lock nut
3	Washer
4	O ring

2. Check to see that there is no foreign matter on the thread part, seat surface of the O ring port (2), or O ring (1). Before fitting, apply hydraulic oil or grease onto the seat surface (2) and O ring (1).

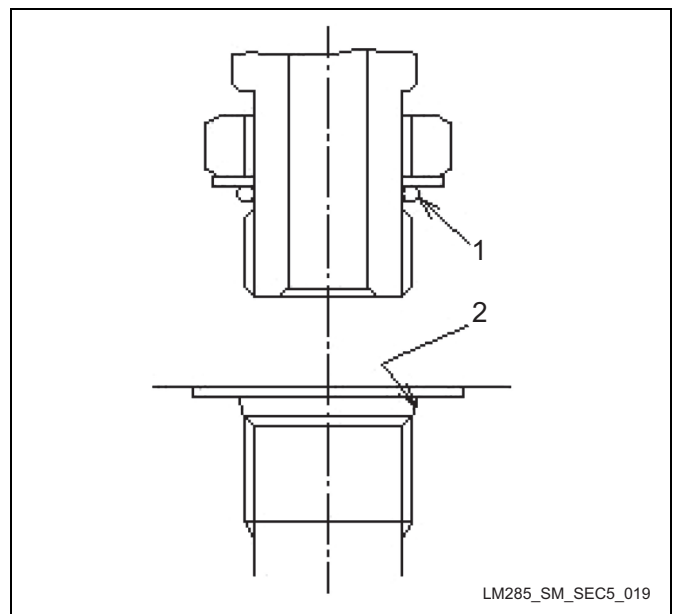

Figure: Hydraulic system-19-a

1	O ring
2	Seat surface

Hydraulic system

Caution

Be careful never to turn more than once. Turning more than once will worsen the fit between the other port and the thread of the lock nut, and reduce the strength of the thread.

Too much penetration of the washer into the other port will cause the washer to deform, leading to the leakage of oil.

Forced fitting results in too much load on the main body and nut, and may cause deformation. Be sure to follow the fitting procedures.

3. To fit, screw in the main body by hand till the washer face touches lightly, and turn from that position in the loosening direction to the preset position.
4. After fitting the opposite screw, tighten the lock nut while holding the main body with a spanner to ensure that the preset position does not change.

Towing

Important

Going over the limit of towing may lead to the failure of hydraulic equipment. Also, if the machine is towed at high speed, the wheel may cease its motion. Stop towing in case of wheel lock. Resume towing at low speed after the pressure has been stabilized.

In the event of loss of mobility due to engine trouble or the like of, movement is possible through towing or hand driving. Take the shortest route when towing or hand driving the machine. Transport on a trailer if you have to transport the machine a long way. For the towing method, see the Owner's manual.

Neutral

If the machine goes forward or in reverse without pressing on the forward/reverse pedals, the neutral is not working. Adjust accordingly.

Refer to the Owner's manual for adjustment of the neutral.

Depressurization

Be sure to depressurize the hydraulic system before inspecting and repairing it. For depressurizing, move the machine to a level place. Apply the parking brake and lower the work machine and mower unit. Then, stop the engine and remove the key. To depressurize the hydraulic circuit, set the forward/reverse pedals and all the drives of

the operating machine in the neutral position. To depressurize the steering circuit, turn the steering wheel from side to side.

Hydraulic circuit failure

The hydraulic traveling circuit of this equipment is made up of a closed circuit. In the event of failure of the hydraulic equipment of the hydraulic circuit, debris and contaminant from the faulty hydraulic equipment will circulate to every part of the circuit. Since this contaminant causes damage to other hydraulic equipment, such debris and contaminant must be removed to prevent further failure of other hydraulic equipment.

In the event that failure of hydraulic equipment is found in the hydraulic circuit, remove hydraulic hoses and piping of the whole hydraulic circuit and clean them well with kerosene and so on. Drain all the hydraulic oil from hydraulic tank and hydraulic equipment other than the hydraulic hoses and piping and clean well.

We recommend to replace the hydraulic oil, hydraulic oil filter and defective hydraulic equipment with new ones.

Hydraulic circuit flow

Traveling circuit

Forward

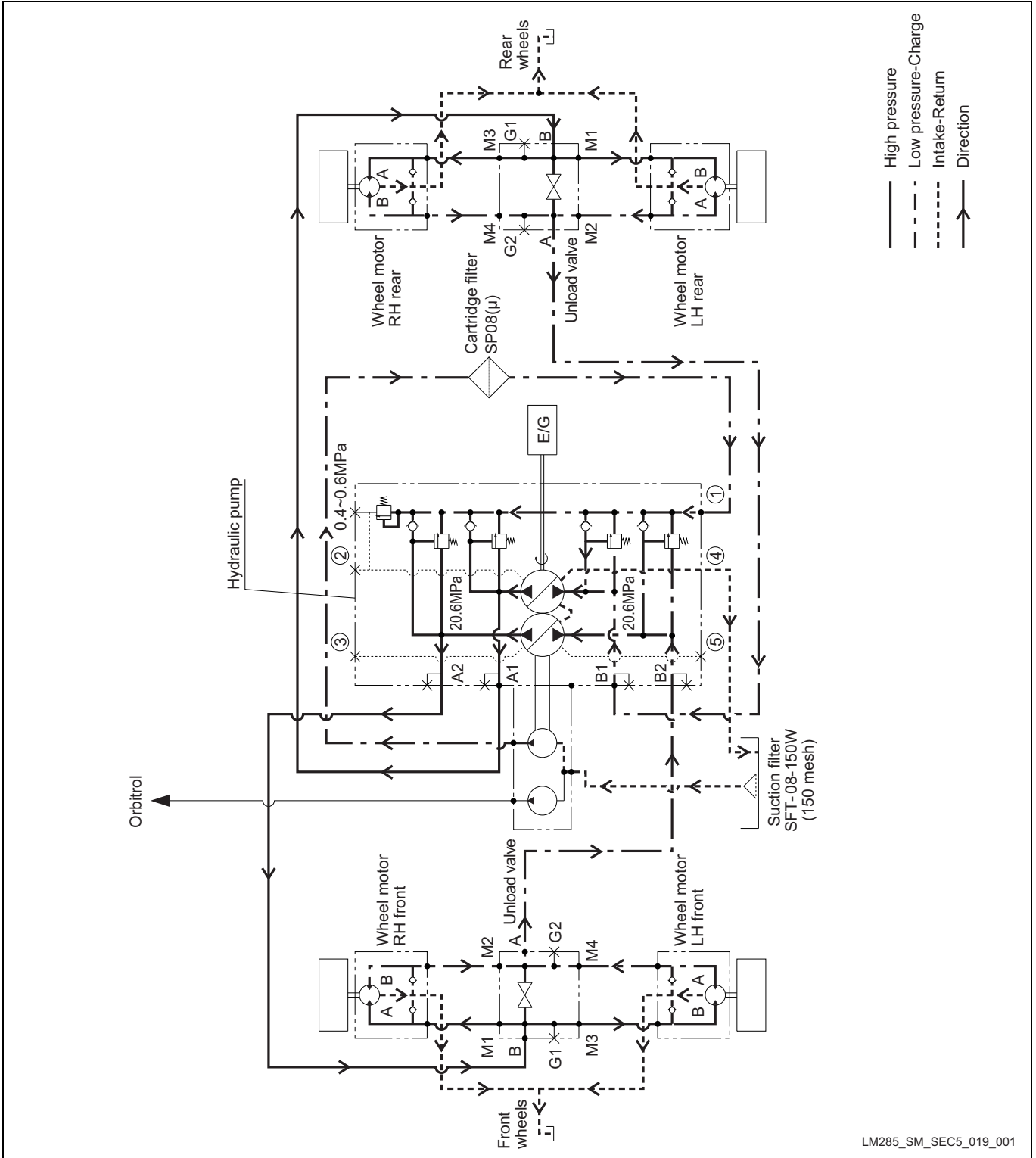

Hydraulic system

Reverse

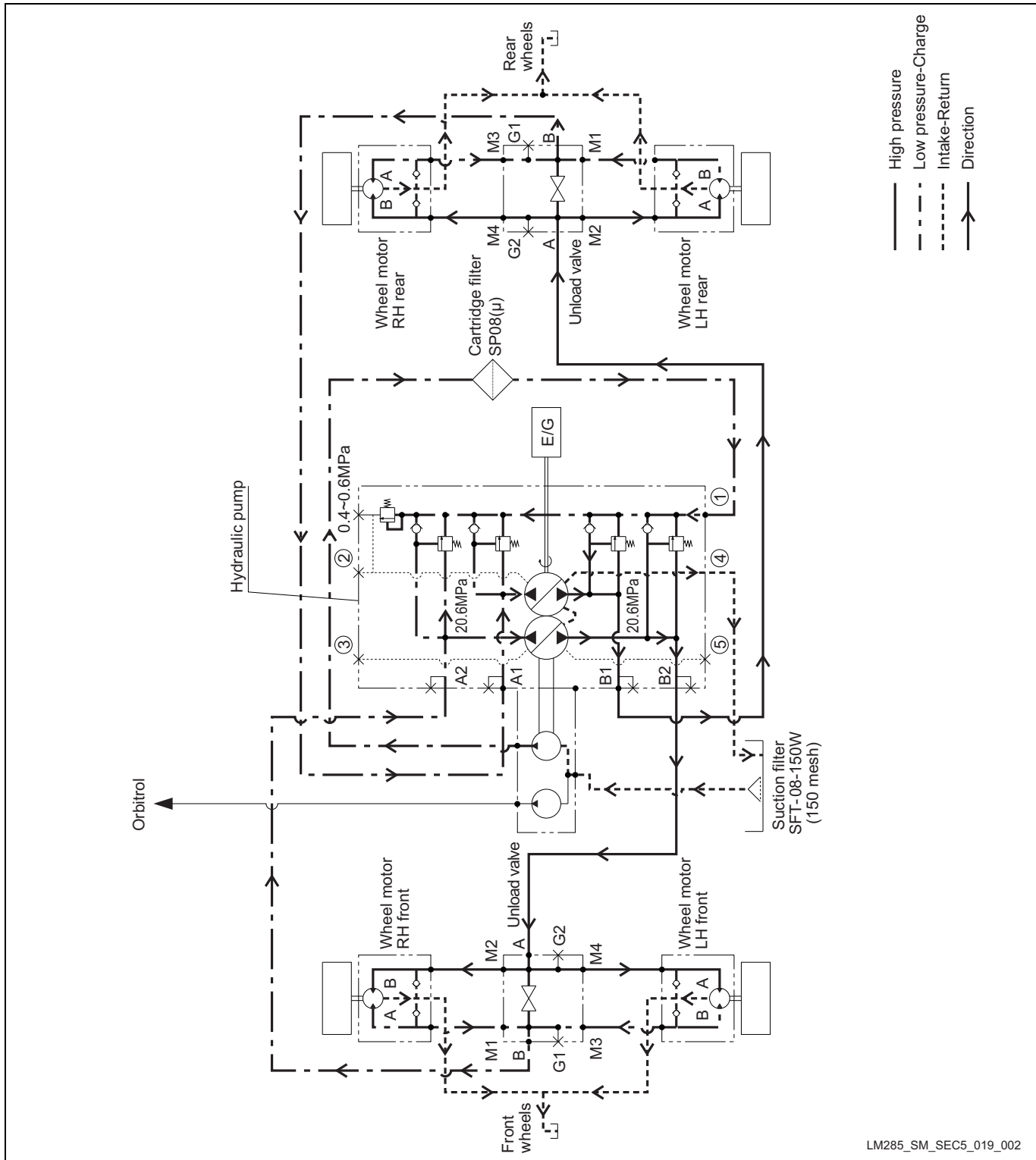

Figure: Hydraulic system-21-a

Raising/lowering circuit

Raising/lowering cylinder Raising

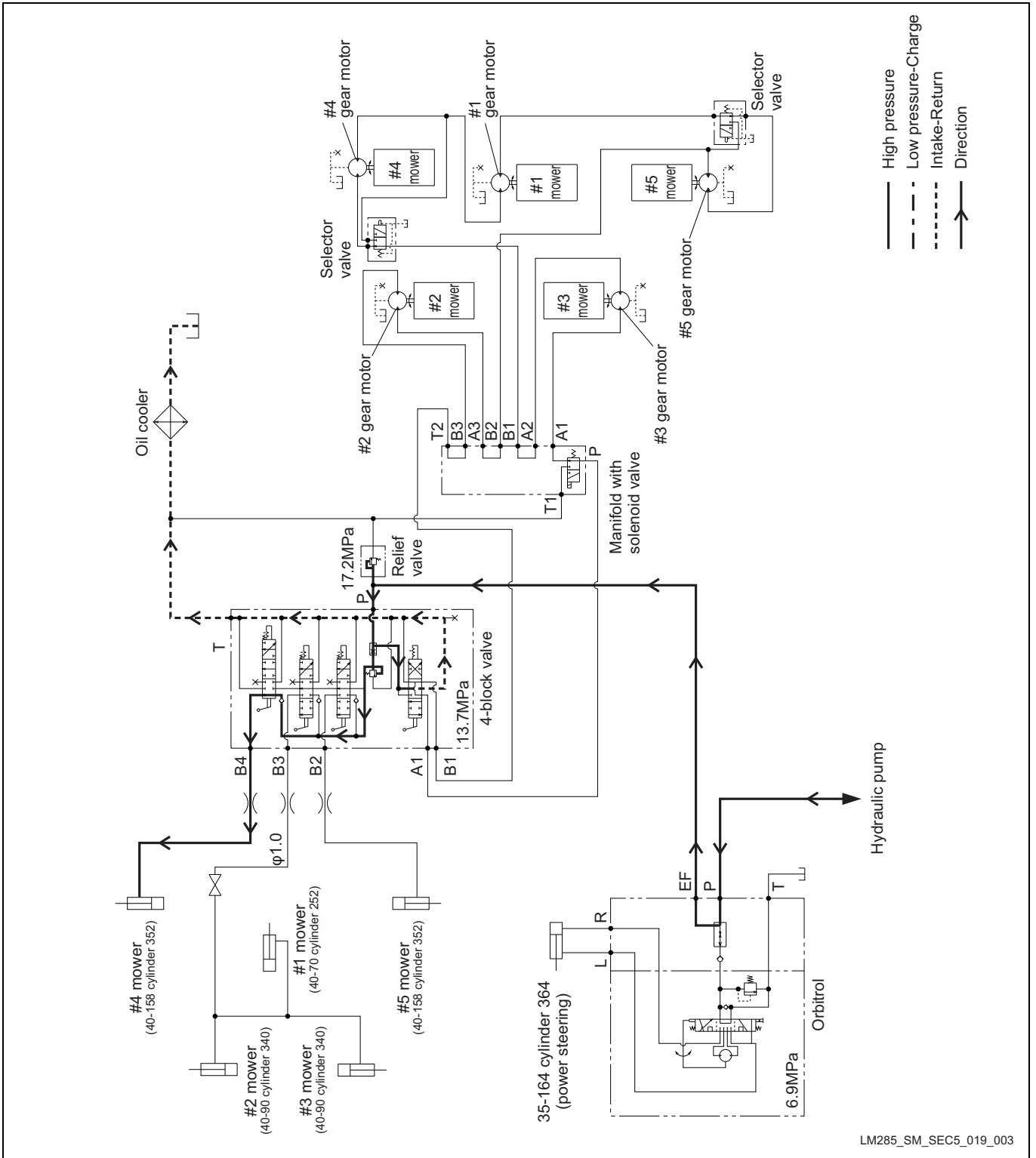

Figure: Hydraulic system-22-a

Hydraulic system

Raising/lowering cylinder Lowering

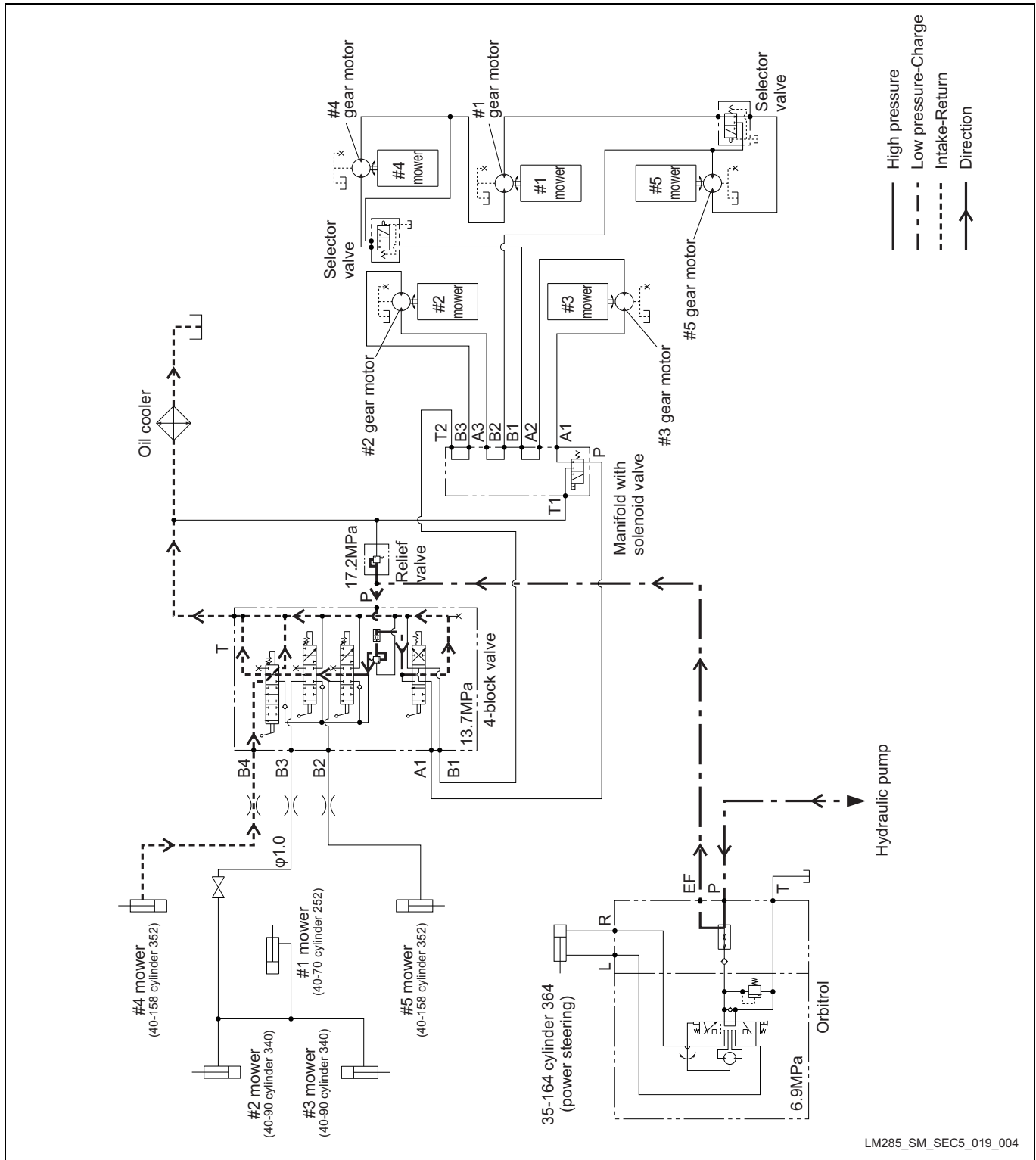

Figure: Hydraulic system-23-a

Steering circuit

Steering cylinder Counter-clockwise turning

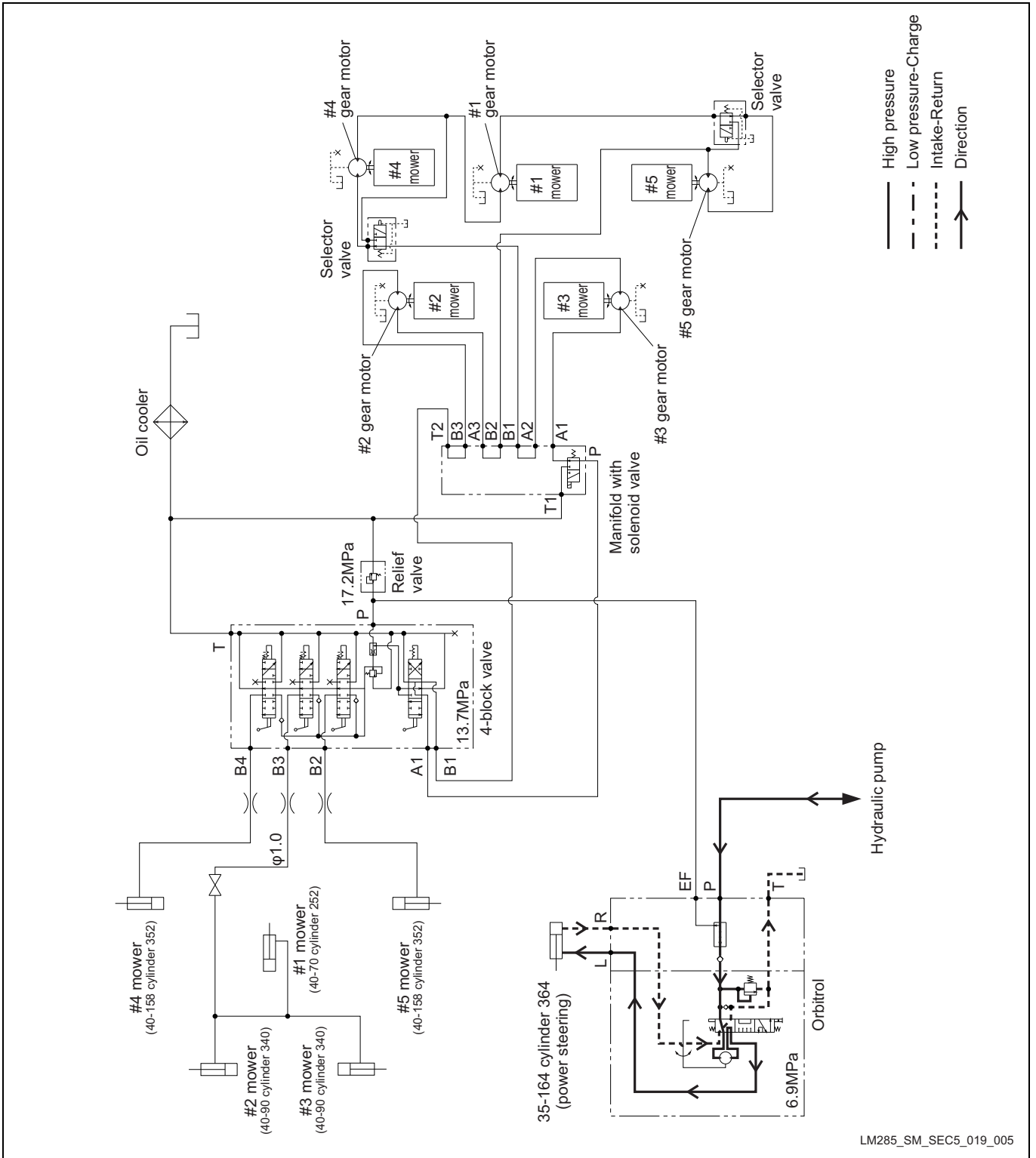

Figure: Hydraulic system-24-a

Hydraulic system

Steering cylinder Clockwise turning

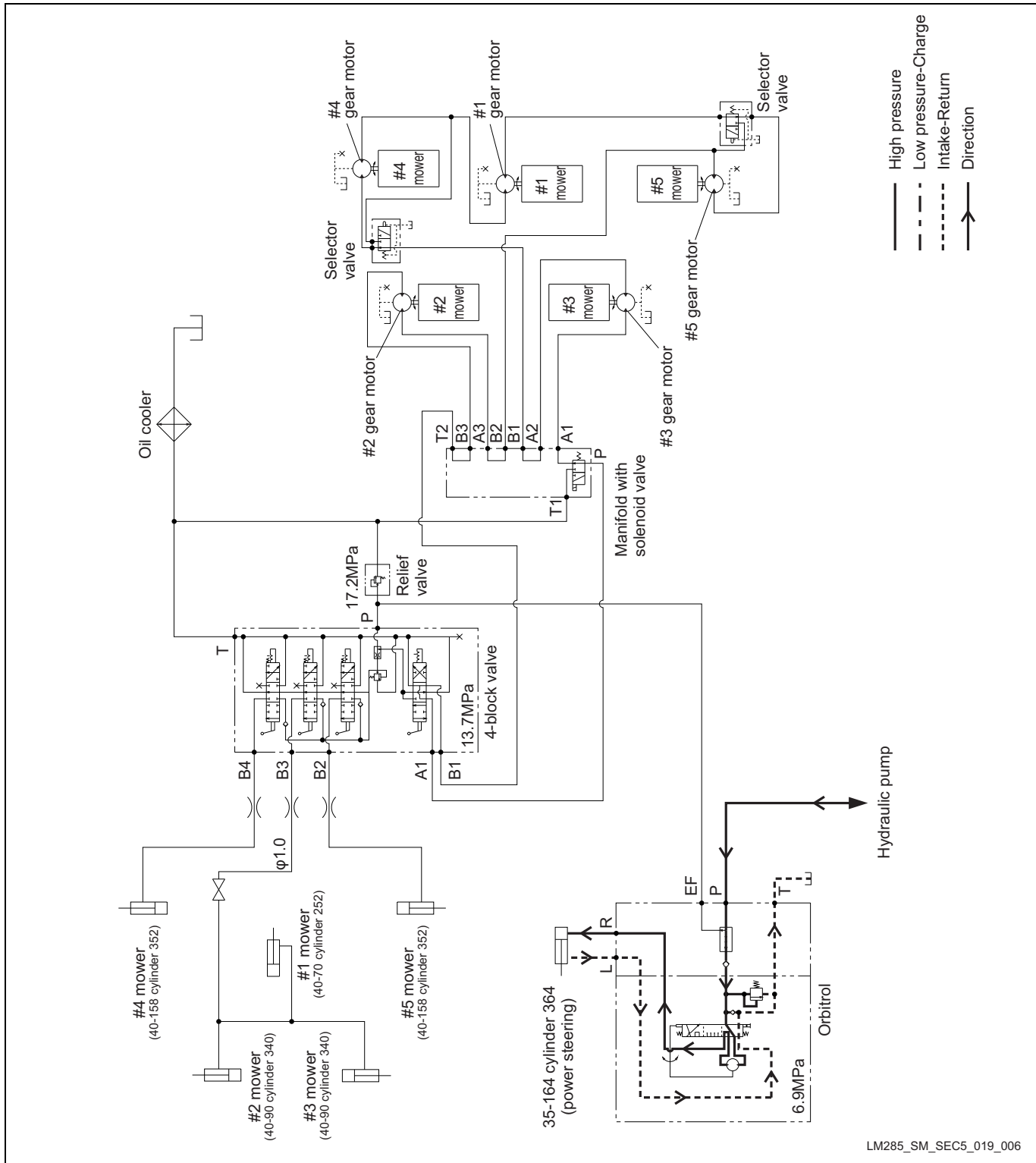

Figure: Hydraulic system-25-a

Reel rotation circuit

Reel positive rotation (operation)

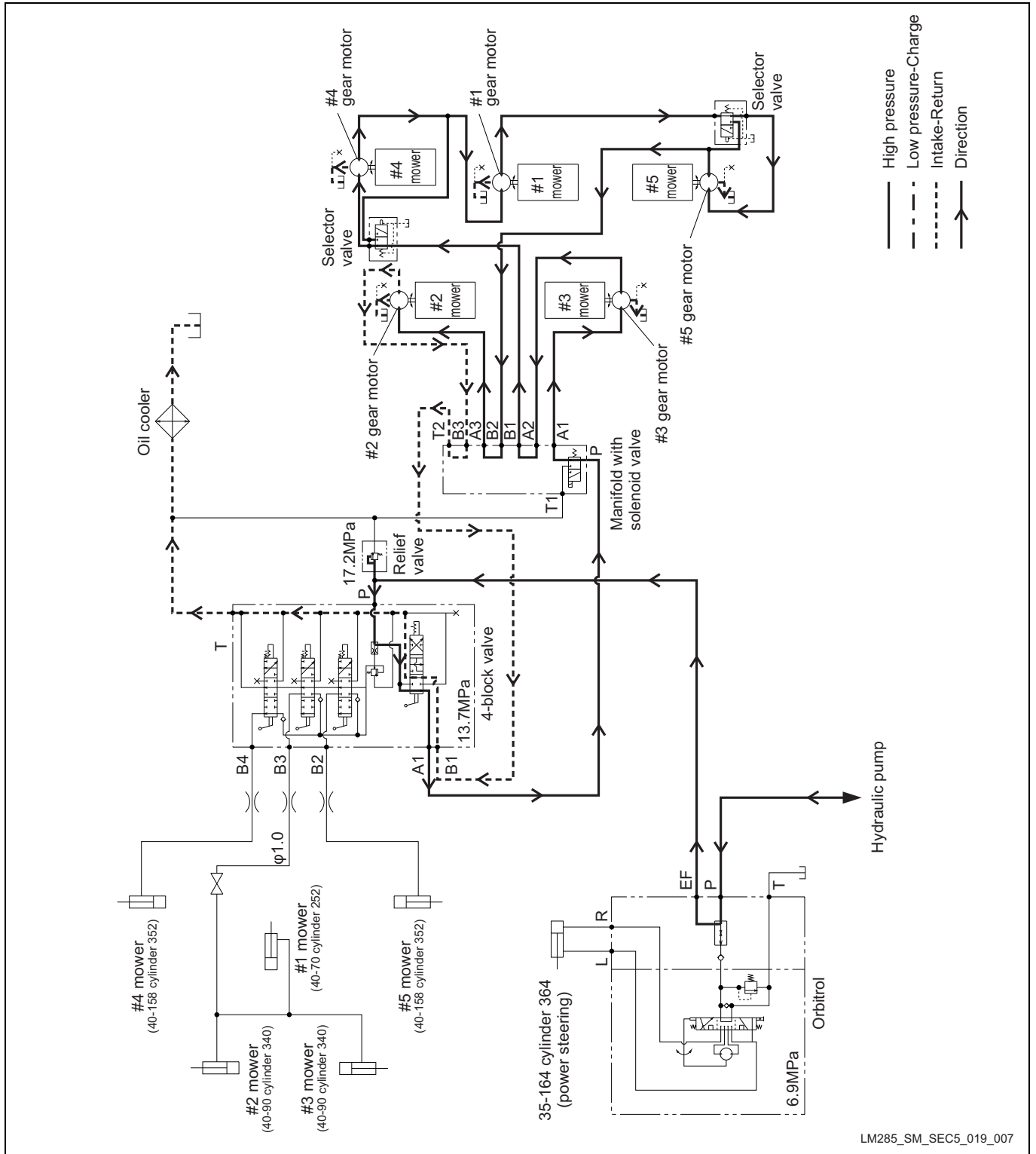

Figure: Hydraulic system-26-a

Hydraulic system

Reel negative rotation (lapping)

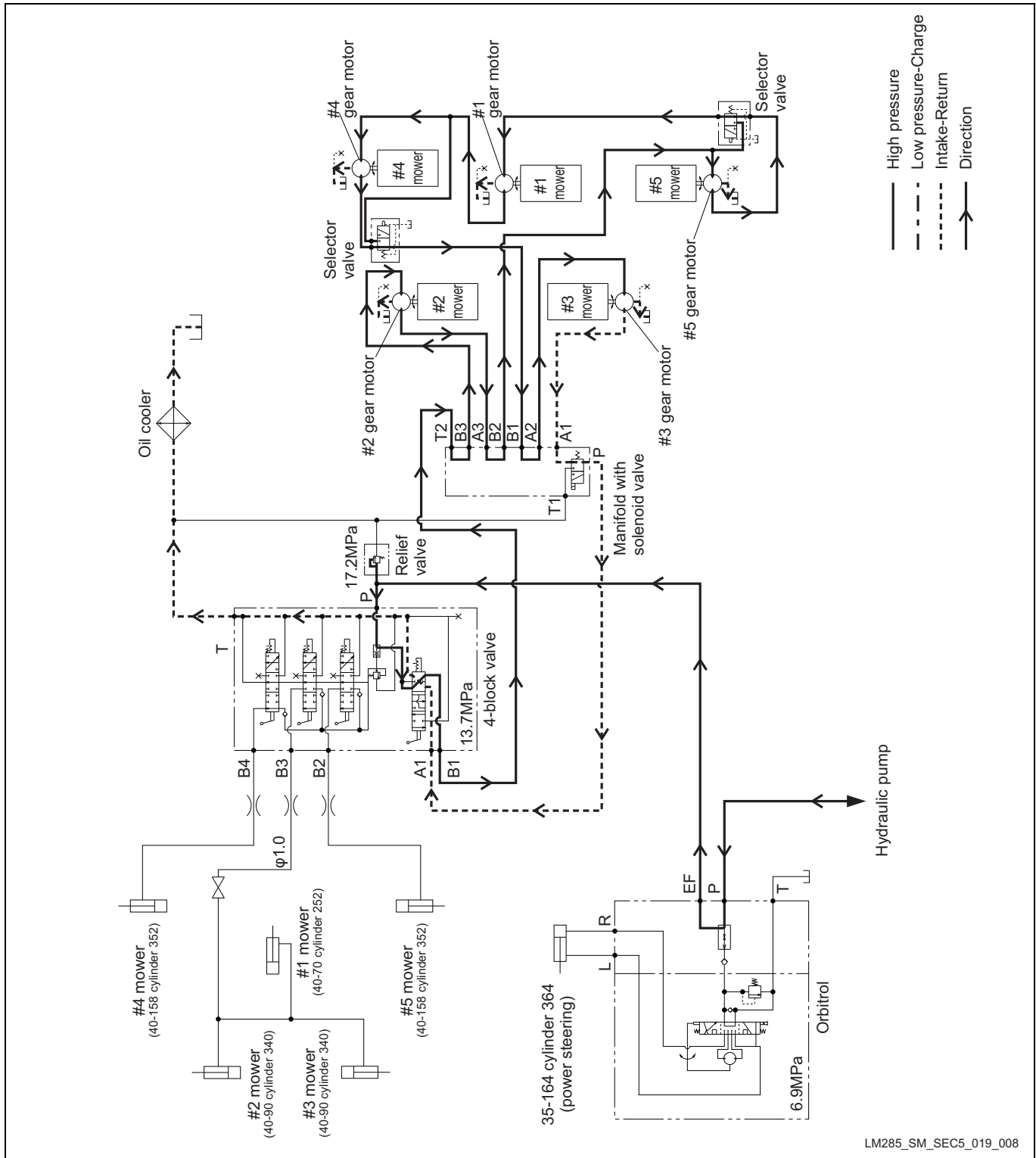
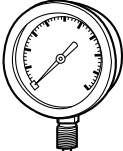

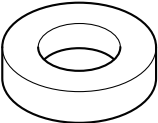
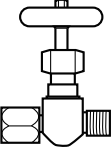
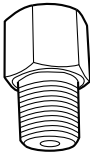
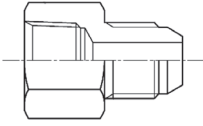
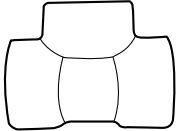
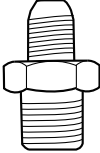
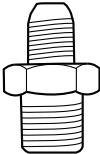
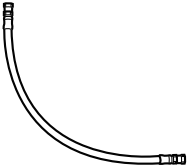
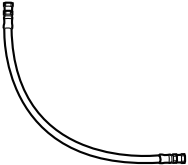
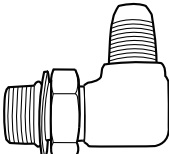

Figure: Hydraulic system-27-a

Special tools

<p>Pressure gauge for high-pressure measurement</p>  <p>LM285_SM_SEC5_020</p>	<p>K4701000010</p>	<p>Pressur: For 0 - 35 MPa For 0 - 5,076.40 psi For 0 - 350.90 kgf/cm²</p> <p>Used mainly for measurement of the pressure on the high side.</p>
<p>Pressure gauge for low-pressure measurement</p>  <p>LM285_SM_SEC5_020</p>	<p>K4701000020</p>	<p>Pressure: For 0 - 15 MPa For 0 - 2,175.60 psi For 0 - 152.96 kgf/cm²</p> <p>Used mainly for measurement of the pressure on the low side.</p>
<p>Pressure gauge for ultralow-pressure measurement</p>  <p>LM285_SM_SEC5_020</p>	<p>K4701000030</p>	<p>Pressure: For 0 - 5 MPa For 0 - 725.20 psi For 0 - 50.99 kgf/cm²</p> <p>Used mainly for measurement of the pressure on the ultralow side.</p>
<p>Packing for pressure gauge</p>  <p>LM285_SM_SEC5_023</p>	<p>K4701000050</p>	<p>Used by inserting between the pressure gauge and the joint for the pressure gauge.</p>
<p>Gauge valve</p>  <p>LM285_SM_SEC5_024</p>	<p>K4701000060</p>	<p>Used for temporarily blocking fluid of measurement for pressure gauge maintenance, inspection, repair etc.</p>
<p>Joint for pressure gauge</p>  <p>LM285_SM_SEC5_025</p>	<p>K4701000040</p>	<p>Used as a joint for pressure piping.</p>

Hydraulic system

<p>Female connector 1015-04</p>  <p>LM285_SM_SEC5_026</p>	<p>K3009000290-Y</p>	<p>Used as a connector when fitting the hydraulic hose to the pressure gauge.</p>
<p>Cast iron screw T shape fitting PT3/8 PF3/8</p>  <p>LM285_SM_SEC5_027</p>	<p>K3204000042-Y</p>	<p>Used when pressure gauge used between hydraulic hoses.</p>
<p>Special adapter PF1/4 PT3/8</p>  <p>LM285_SM_SEC5_028</p>	<p>K3009000042-Y</p>	<p>Used for extension of screw T shape fitting for pressure measurement.</p>
<p>Special adapter 1013-9</p>  <p>LM285_SM_SEC5_028</p>	<p>K3009000010-Y</p>	<p>2 pieces used for extension of screw T shape fitting for pressure measurement.</p>
<p>WP280-6 Hose 1-600</p>  <p>LM285_SM_SEC5_030</p>	<p>K3107210600</p>	<p>Used as a hydraulic hose for measurement of high-pressure to ultralow-pressure.</p>
<p>WP210-9 Hose 1-490</p>  <p>LM285_SM_SEC5_030</p>	<p>K3105310490</p>	<p>Used as a hydraulic hose for measurement of high-pressure to ultralow-pressure</p>
<p>90 Adjuster elbow 1086-9</p>  <p>LM285_SM_SEC5_032</p>	<p>K3008000032-Y</p>	<p>Used for extension when pressure gauge fitted to pressure measurement port.</p>

Measurement method

Note

The most effective way of solving problems in the hydraulic system is to use a measuring instrument such as a pressure gauge for measurement.

Before hydraulic measurement

Important

Before concluding that the problem in the hydraulic system is caused by the hydraulic equipment, every part of the hydraulic system must be checked for issues related to oil fill, oil filter, loosening of fasteners, lack of adjustment and so on.

Note on hydraulic measurement

Warning

As mentioned in the testing procedure, the use of a pressure gauge not meeting the pressure measurement standard may result in damage to the pressure gauge or leakage of high-pressure oil. Be careful about high-pressure oil which may pierce your skin, resulting in physical injury.

Warning

Carry out hydraulic measurement with two or more persons. One person should be in the driver's seat to operate the machine and the other person should engage in measurement and recording.

Caution

When checking for pinhole leakage of the hydraulic circuit or oil leakage of the nozzle, search for a leakage point using something like paper or cardboard, never with your bare hands. Be careful about high-pressure oil which may pierce your skin, resulting in physical injury.

1. Always clean the machine before hydraulic measurement. Remember that the machine must always be kept clean for hydraulic measurement. Contamination may lead to clogging or breakage of the hydraulic circuit.
2. Review the measuring method before starting measurement.

3. Before measurement, check for maladjustment, clogging or breakage.
4. Warm up the hydraulic oil before starting hydraulic measurement.

Warning

Be sure to depressurize the hydraulic system before inspecting or repairing it.

5. When hydraulic equipment is removed, cap or plug it to prevent contamination of the hydraulic system.
6. When using a measuring instrument such as a pressure gauge, connect the in/out hoses correctly. Never connect the other way round to prevent breakage of the hydraulic system and measuring instrument.
7. Screw in the hydraulic fitting by hand till it touches the other side lightly, then fasten with a wrench.
8. Fit hoses and measuring instruments in such a way as to avoid contact with the driving part of the machine.
9. After connecting a measuring instrument, check the amount of oil in the hydraulic tank.
10. Check to see that the engine is in good condition. Carry out hydraulic measurement with the engine running at maximum speed.
11. In case there is any problem in the traveling circuit, carry out the following measurement.
 - [1] Charge relief valve pressure
 - [2] Traveling relieve valve pressure
12. In case there is any problem in the raise/ lower or steering circuit, carry out the following measurement.
 - [1] Relief valve pressure
 - [2] Oil leakage inside the hydraulic cylinder

Hydraulic system

Traveling circuit

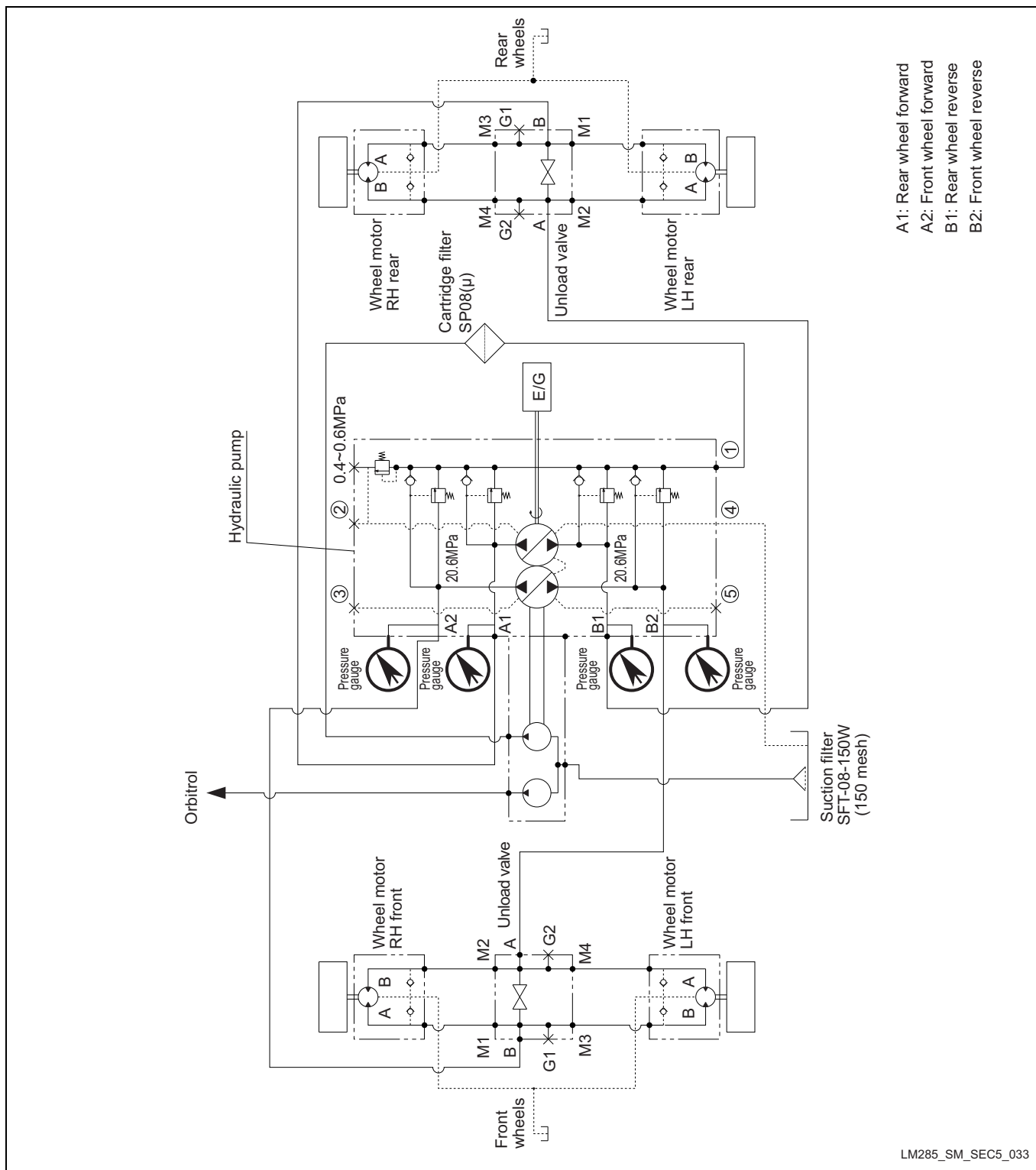

Figure: Hydraulic system-28-a

Front wheel

■ In the case of forward side

1. Pull the slide lever (1) and slide the seat (2) to the forward end.

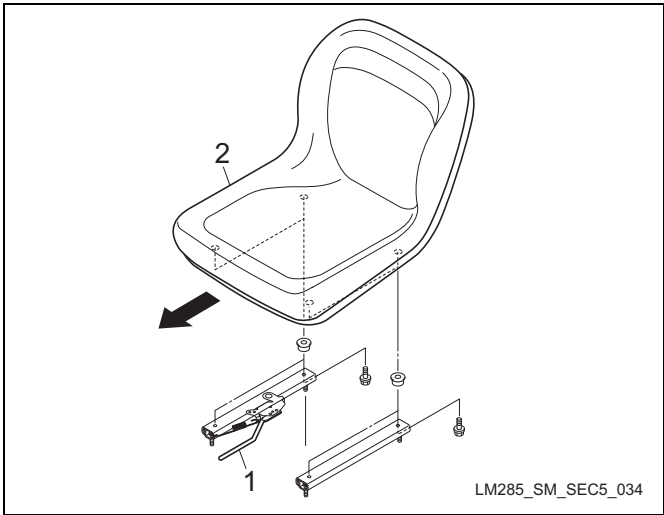

Figure: Hydraulic system-29-a

1	Slide lever
2	Seat

2. Remove the bolts (2), S washers (3) and washers (4) behind the seat, which fasten the cover under seat (1).

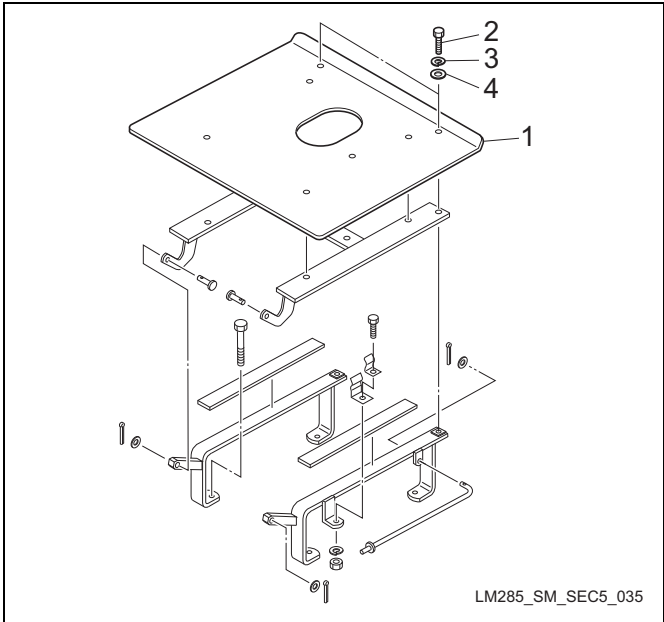

Figure: Hydraulic system-30-a

1	Cover under seat
2	Bolt
3	S washer
4	Washer

3. Lift up the seat (1).

4. Insert and fix the stand (2) to the seat mounting plate (3).

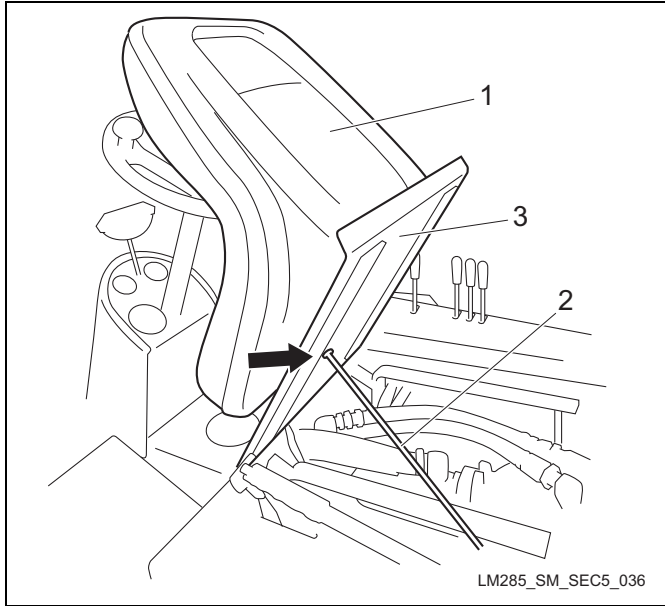

Figure: Hydraulic system-31-a

1	Seat
2	Stand
3	Seat mounting plate

5. Remove the plug (3) of the front wheel forward side measurement port (2) of the piston pump (1).

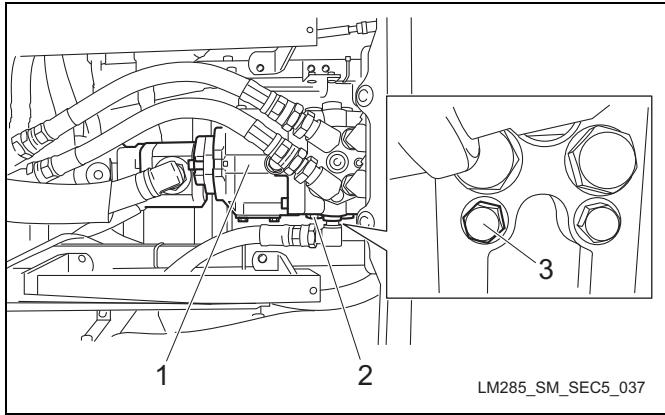

Figure: Hydraulic system-32-a

1	Piston pump
2	Front wheel forward side measurement port
3	Plug

Hydraulic system

- Fit the pressure gauge for high-pressure measurement (2) to the front wheel forward side measurement port (1).

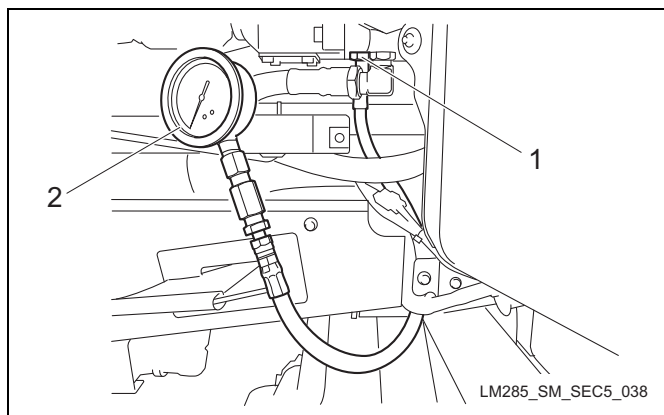

Figure: Hydraulic system-33-a

1	Front wheel forward side measurement port
2	Pressure gauge for high-pressure measurement

- Apply resistance to the machine by using a sling or the like from the rear lower side of the machine to the frame (1).

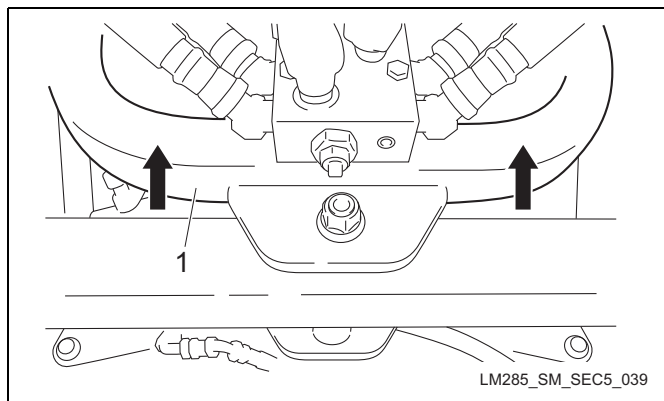

Figure: Hydraulic system-34-a

1	Frame
---	-------

- Start the engine and accelerate to the maximum speed. Press on the traveling pedal for forward direction. It is considered normal if the pressure is 20.6MPa (2,987.78psi) with the tires in a locked and nonslip condition.

■ In the case of reverse side

- Pull the slide lever (1) and slide the seat (2) to the forward end.

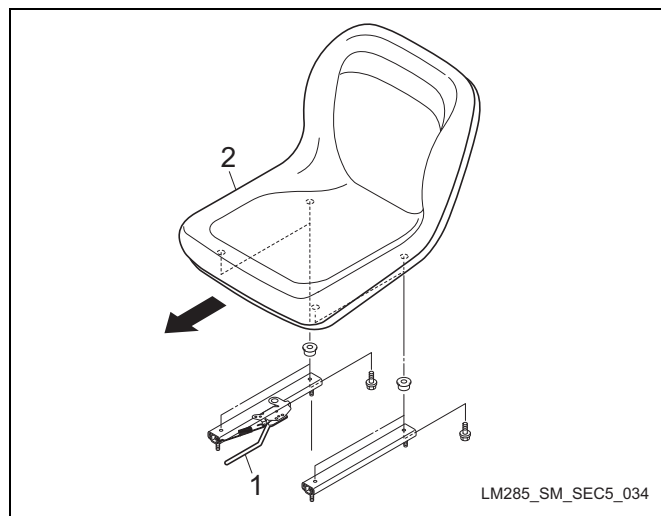

Figure: Hydraulic system-35-a

1	Slide lever
2	Seat

- Remove the bolts (2), S washers (3) and washers (4) behind the seat, which fasten the cover under seat (1).

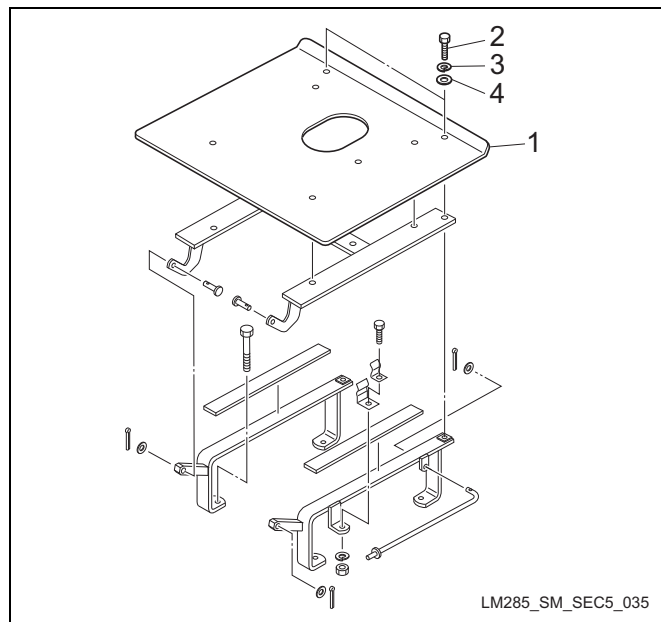

Figure: Hydraulic system-36-a

1	Cover under seat
2	Bolt
3	S washer
4	Washer

- Lift up the seat (1).

4. Insert and fix the stand (2) to the seat mounting plate (3).

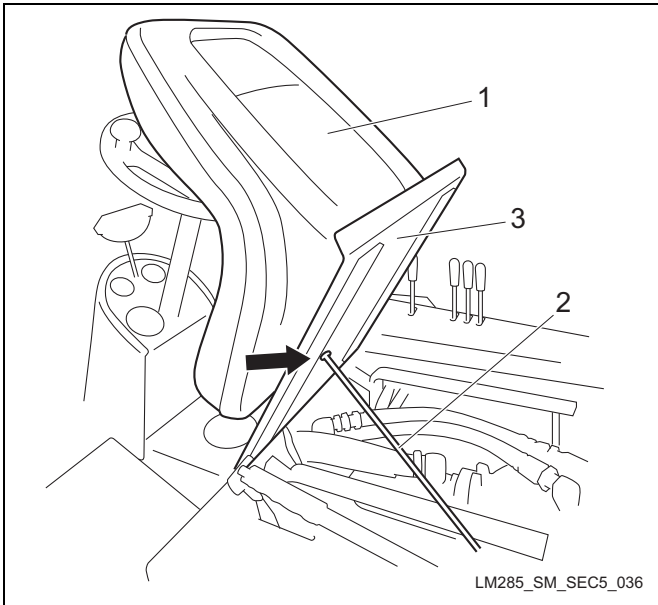

Figure: Hydraulic system-37-a

1	Seat
2	Stand
3	Seat mounting plate

5. Remove the connector (2) of the limit switch (1).

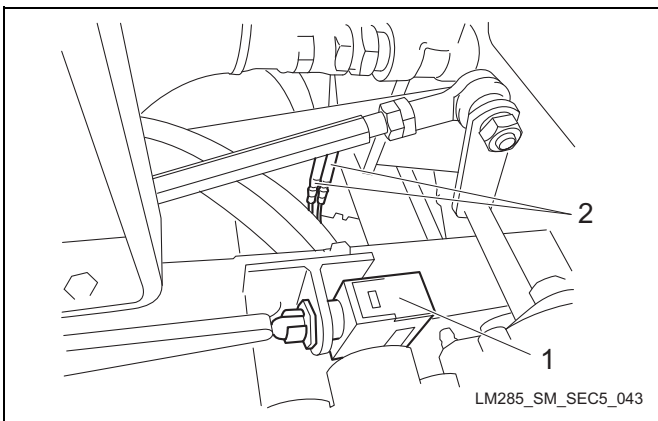

Figure: Hydraulic system-38-a

1	Limit switch
2	Connector

6. Link the connector (1) of the 4-block valve side directly.

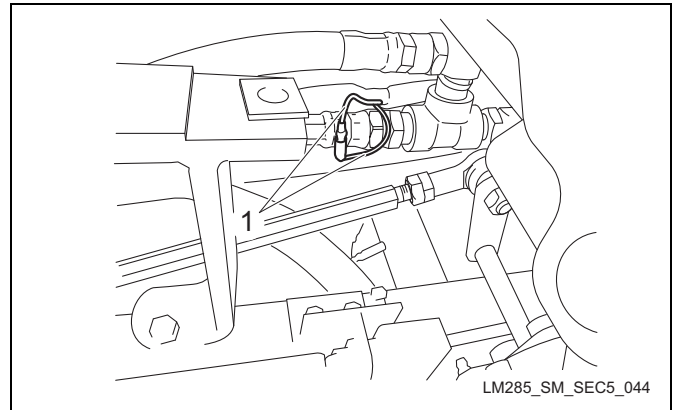

Figure: Hydraulic system-39-a

- | | |
|---|--------------------------------------|
| 1 | Connector of the 4-block valve side. |
|---|--------------------------------------|
7. Remove the bolts (2) fastening the switch mounting base (1) and remove the switch mounting base (1), the switch mounting bracket (3) and the limit switch (4).
 8. Remove the plug (6) of the front wheel reverse side measurement port of the piston pump.(5).

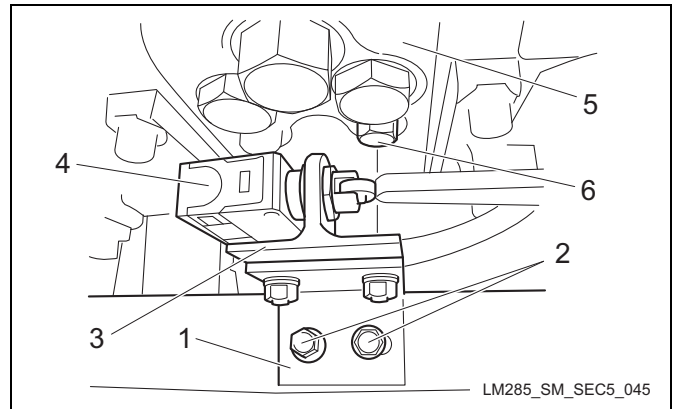

Figure: Hydraulic system-40-a

1	Switch mounting base
2	Bolt
3	Switch mounting bracket
4	Limit switch
5	Piston pump
6	Plug

Hydraulic system

- Attach the adapter (2) to the front wheel reverse side measurement port (1) and fit the pressure gauge for high-pressure measurement (3).

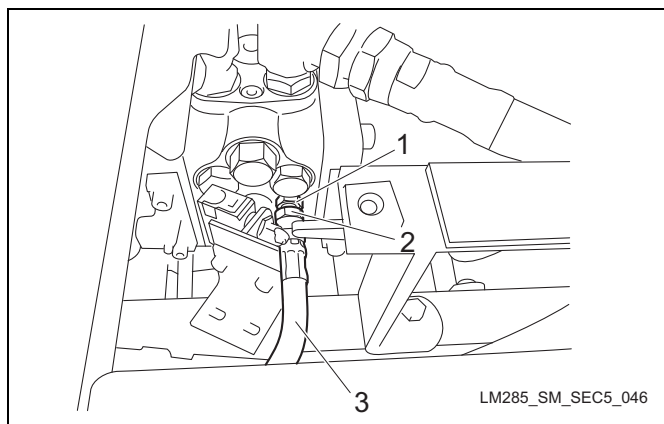

Figure: Hydraulic system-41-a

1	Front wheel reverse side measurement port
2	Adapter
3	Pressure gauge for high-pressure measurement

- Apply resistance to the machine by using a sling or the like to the frame (1).

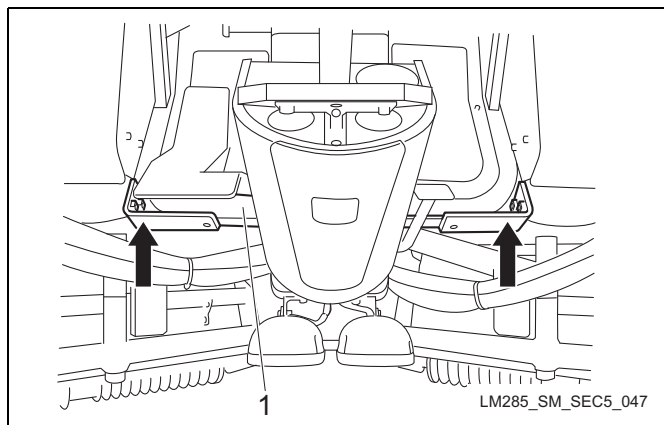

Figure: Hydraulic system-42-a

1	Frame
---	-------

- Start the engine and accelerate to the maximum speed. Press on the traveling pedal for reverse direction. It is considered normal if the pressure is 20.6MPa (2,987.78psi) with the tires in a locked and nonslip condition.

Rear wheel

■ In the case of forward side

- Pull the slide lever (1) and slide the seat (2) to the forward end.

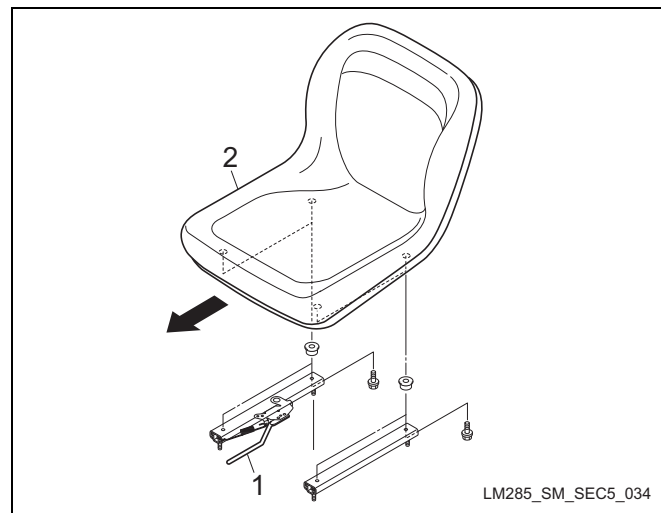

Figure: Hydraulic system-43-a

1	Slide lever
2	Seat

- Remove the bolts (2), S washers (3) and washers (4) behind the seat, which fasten the cover under seat (1).

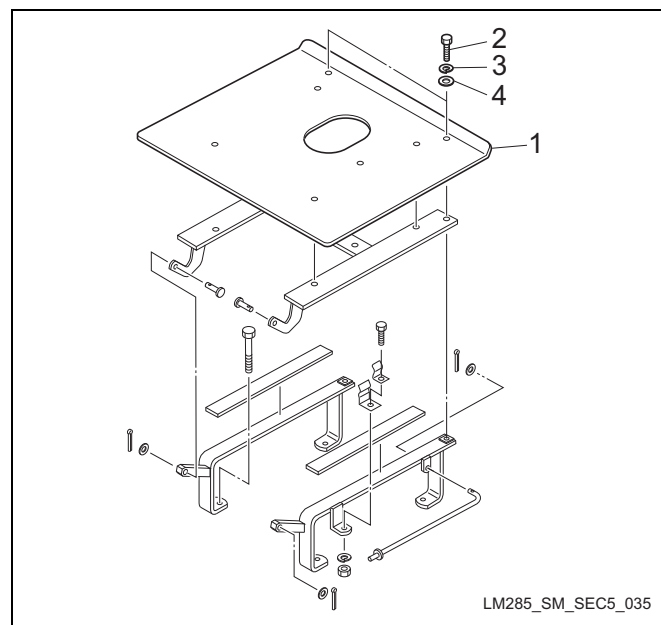

Figure: Hydraulic system-44-a

1	Cover under seat
2	Bolt
3	S washer
4	Washer

- Lift up the seat (1).

4. Insert and fix the stand (2) to the seat mounting plate (3).

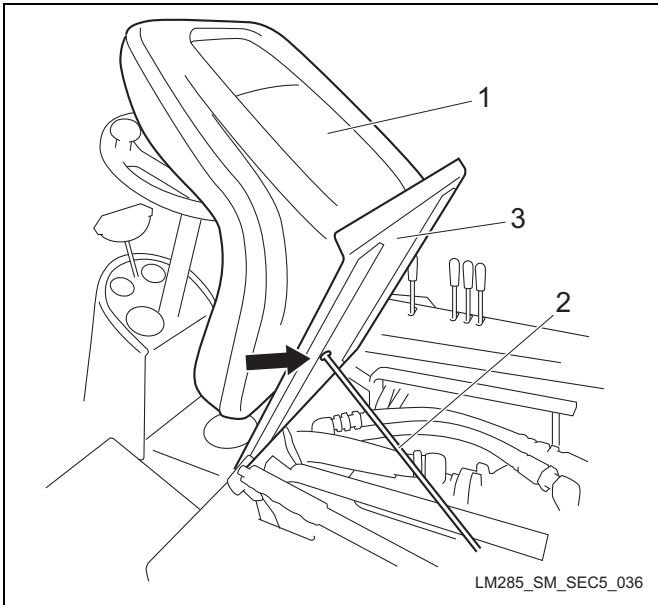

Figure: Hydraulic system-45-a

1	Seat
2	Stand
3	Seat mounting plate

5. Remove the connector (2) of the limit switch (1).

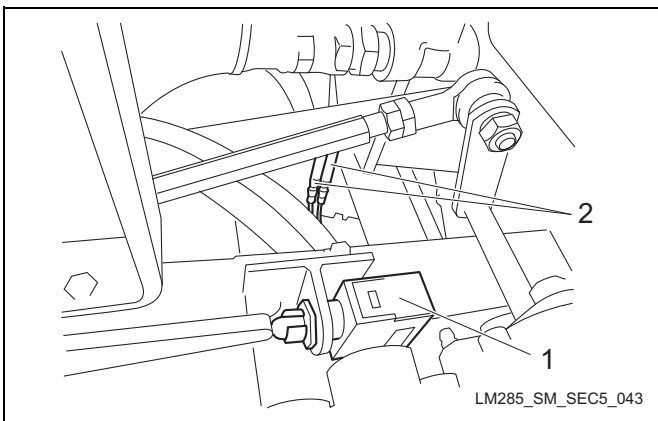

Figure: Hydraulic system-46-a

1	Limit switch
2	Connector

6. Link the connector (1) of the 4-block valve side directly.

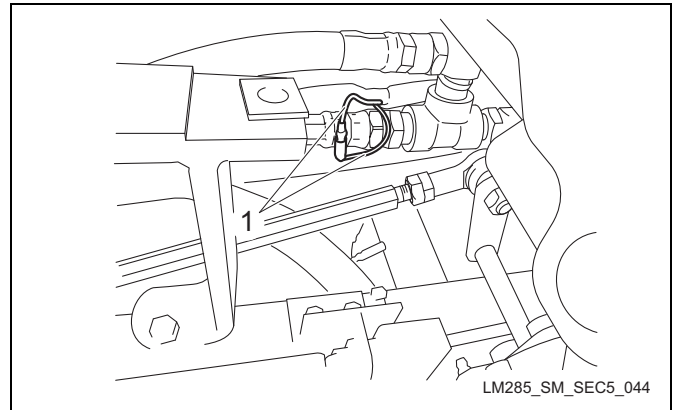

Figure: Hydraulic system-47-a

- | | |
|---|--------------------------------------|
| 1 | Connector of the 4-block valve side. |
|---|--------------------------------------|
7. Remove the bolts (2) fastening the switch mounting base (1) and remove the switch mounting base (1), the switch mounting bracket (3) and the limit switch (4).
 8. Remove the plug (6) of the rear wheel forward side measurement port of the piston pump.(5).

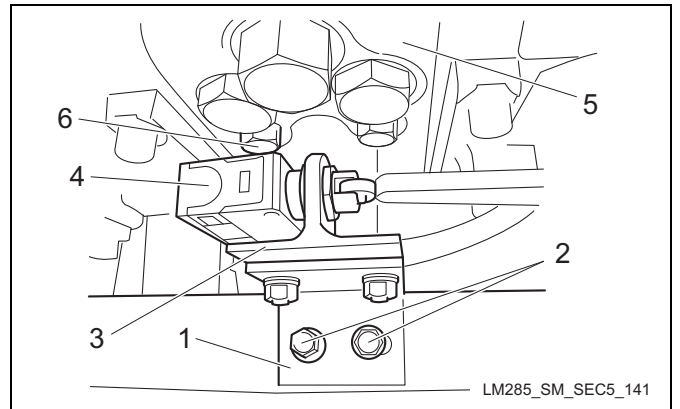

Figure: Hydraulic system-48-a

1	Switch mounting base
2	Bolt
3	Switch mounting bracket
4	Limit switch
5	Piston pump
6	Plug

Hydraulic system

- Attach the adapter (2) to the rear wheel forward side measurement port (1) and fit the pressure gauge for high-pressure measurement (3).

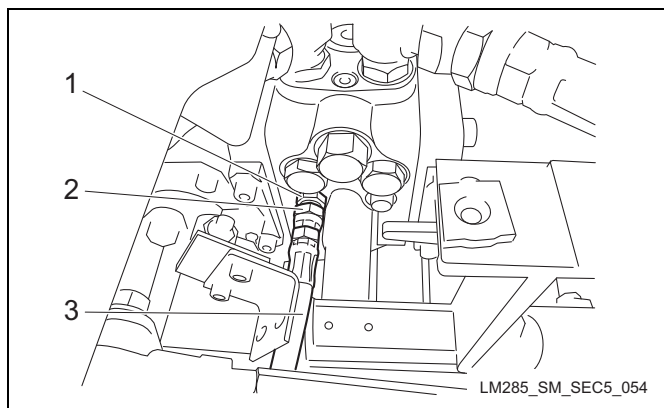

Figure: Hydraulic system-49-a

1	Rear wheel forward side measurement port
2	Adapter
3	Pressure gauge for high-pressure measurement

- Apply resistance to the machine by using a sling or the like to the frame (1).

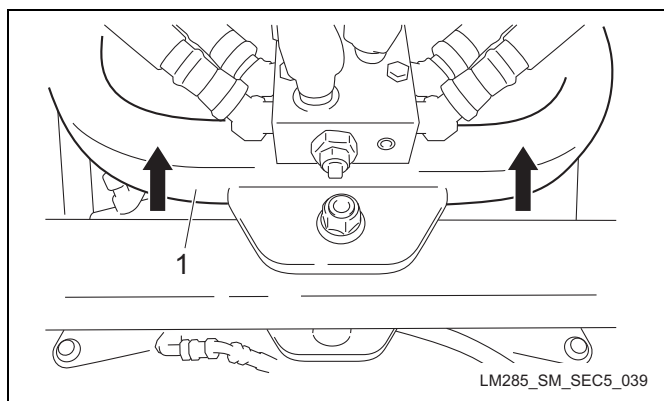

Figure: Hydraulic system-50-a

1	Frame
---	-------

- Start the engine and accelerate to the maximum speed. Press on the traveling pedal for forward direction. It is considered normal if the pressure is 20.6MPa (2,987.78psi) with the tires in a locked and nonslip condition.

■ In the case of reverse side

- Pull the slide lever (1) and slide the seat (2) to the forward end.

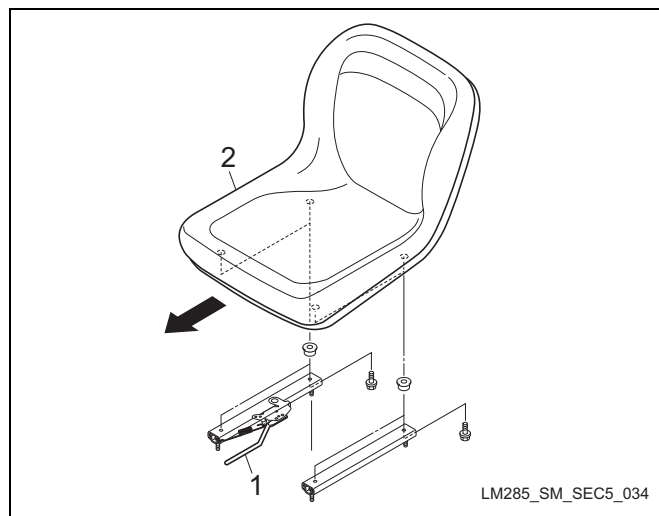

Figure: Hydraulic system-51-a

1	Slide lever
2	Seat

- Remove the bolts (2), S washers (3) and washers (4) behind the seat, which fasten the cover under seat (1).

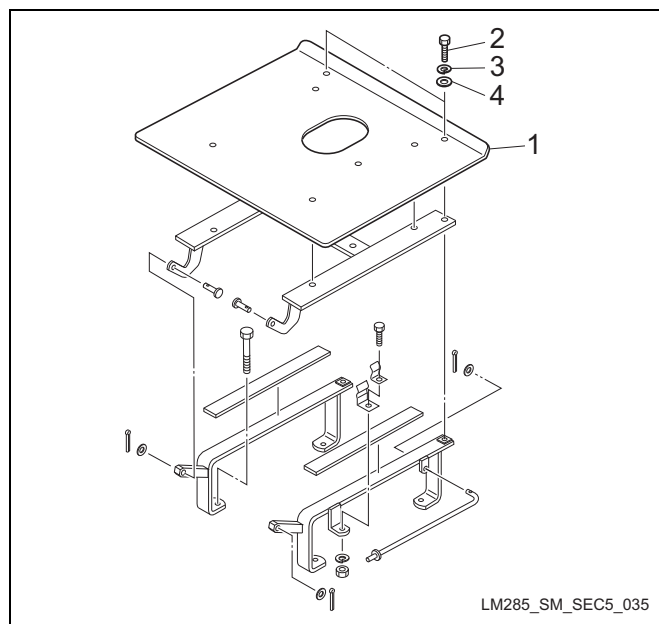

Figure: Hydraulic system-52-a

1	Cover under seat
2	Bolt
3	S washer
4	Washer

- Lift up the seat (1).

4. Insert and fix the stand (2) to the seat mounting plate (3).

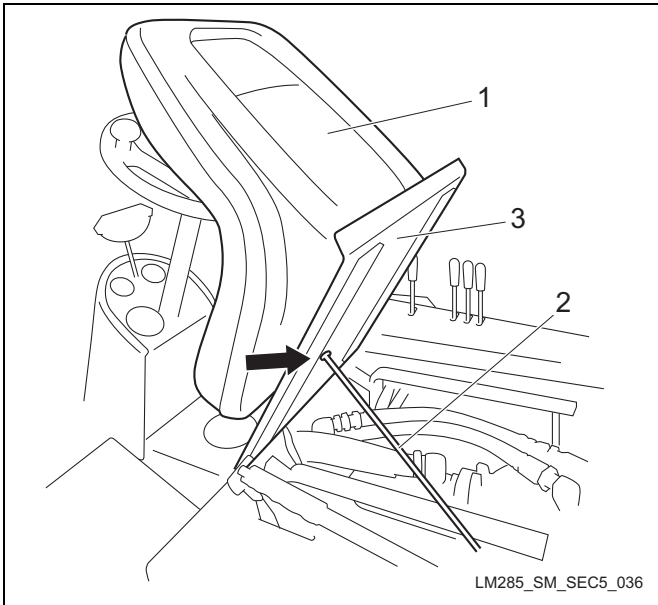

Figure: Hydraulic system-53-a

1	Seat
2	Stand
3	Seat mounting plate

5. Remove the plug (3) of the rear wheel reverse side measurement port (2) of the piston pump (1).

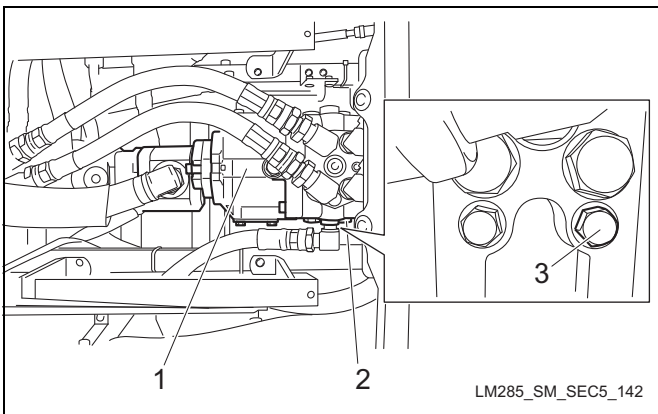

Figure: Hydraulic system-54-a

1	Piston pump
2	Rear wheel reverse side measurement port
3	Plug

6. Fit the pressure gauge for high-pressure measurement (2) to the rear wheel reverse side measurement port (1).

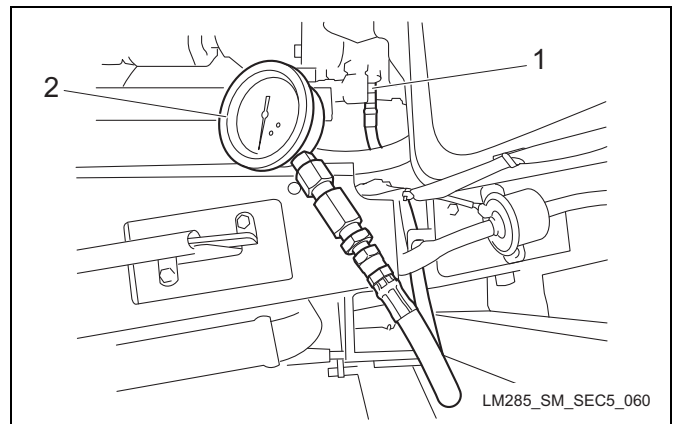

Figure: Hydraulic system-55-a

1	Rear wheel reverse side measurement port
2	Pressure gauge for high-pressure measurement

7. Apply resistance to the machine by using a sling or the like to the frame (1).

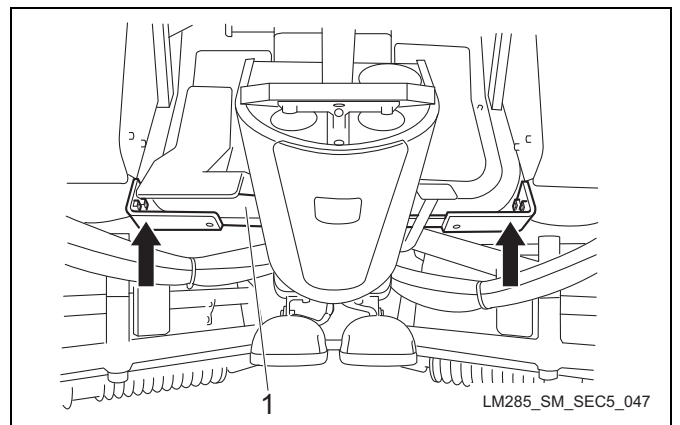

Figure: Hydraulic system-56-a

1	Frame
---	-------

8. Start the engine and accelerate to the maximum speed. Press on the traveling pedal for reverse direction. It is considered normal if the pressure is 20.6MPa (2,987.78psi) with the tires in a locked and nonslip condition.

Hydraulic system

Raising/lowering circuit

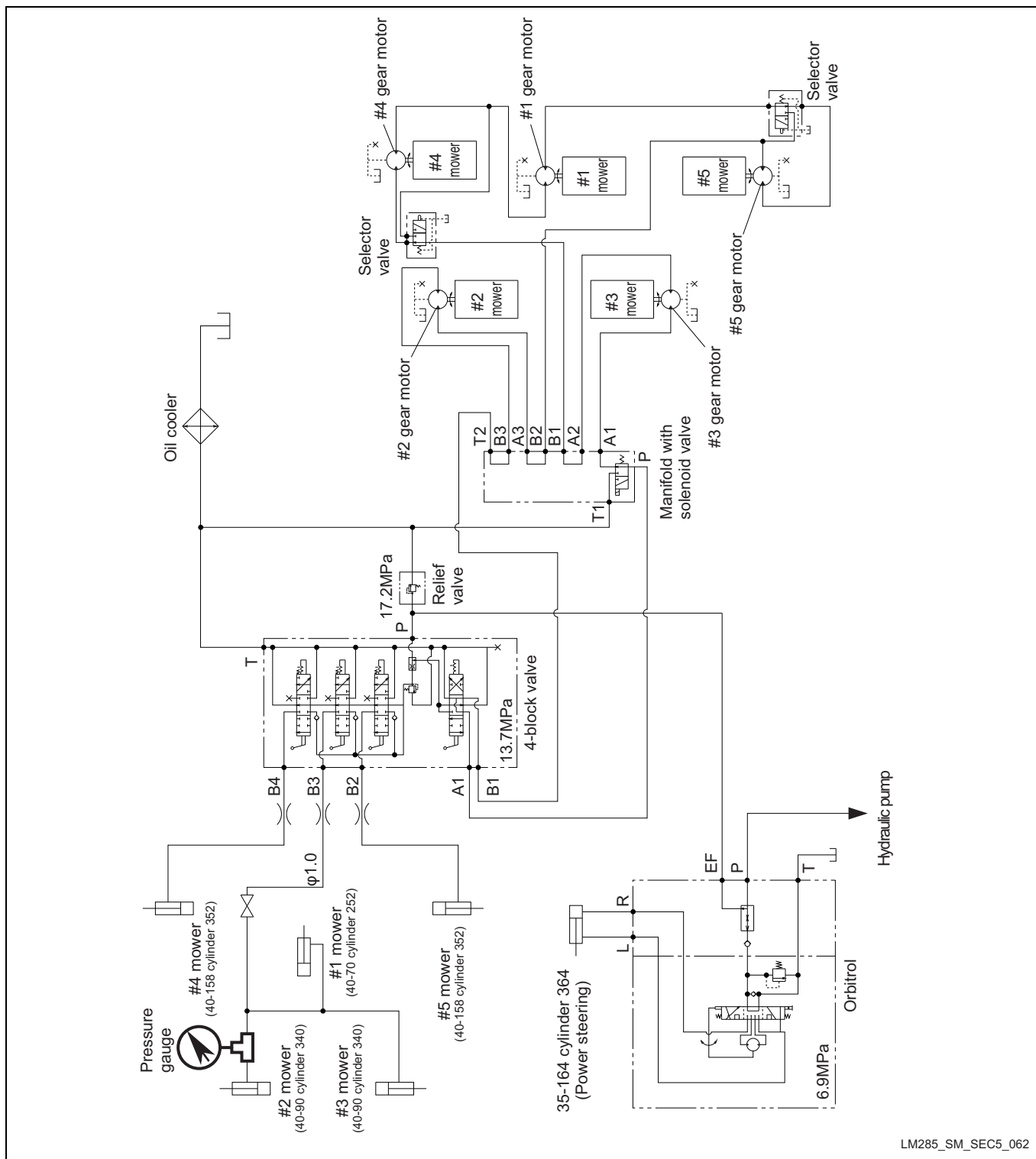

LM285_SM_SEC5_062

Figure: Hydraulic system-57-a

1. Lower the mower units and remove the hydraulic hose (3) from the elbow (2) attached to the cylinder (1).

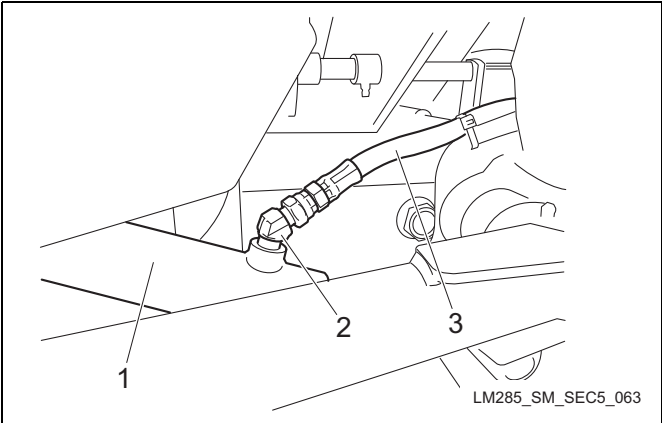

Figure: Hydraulic system-58-a

1	Cylinder
2	Elbow
3	Hydraulic hose

2. Attach the cap (3) to the elbow (1) and fit the pressure gauge for high-pressure measurement (4) to the removed hydraulic hose (2).

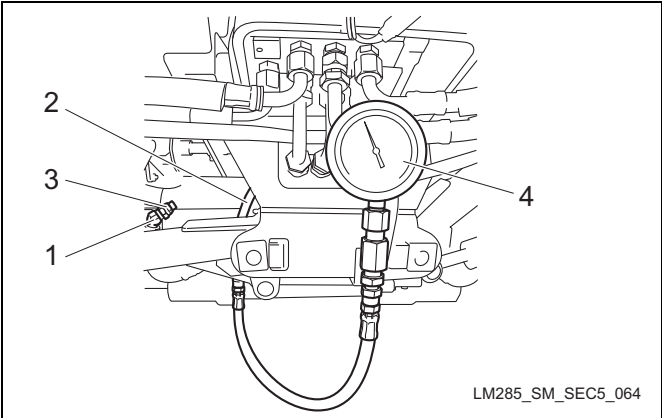

Figure: Hydraulic system-59-a

1	Elbow
2	Hydraulic hose
3	Cap
4	Pressure gauge for high-pressure measurement

3. Start the engine and accelerate to the maximum speed with the mower units lowered. Turn raise/lower lever to "Raise." It is considered normal if the pressure of the pressure gauge is 13.7MPa (1,987.02psi) when the raise/lower cylinder is retracted fully.

Hydraulic system

Steering circuit

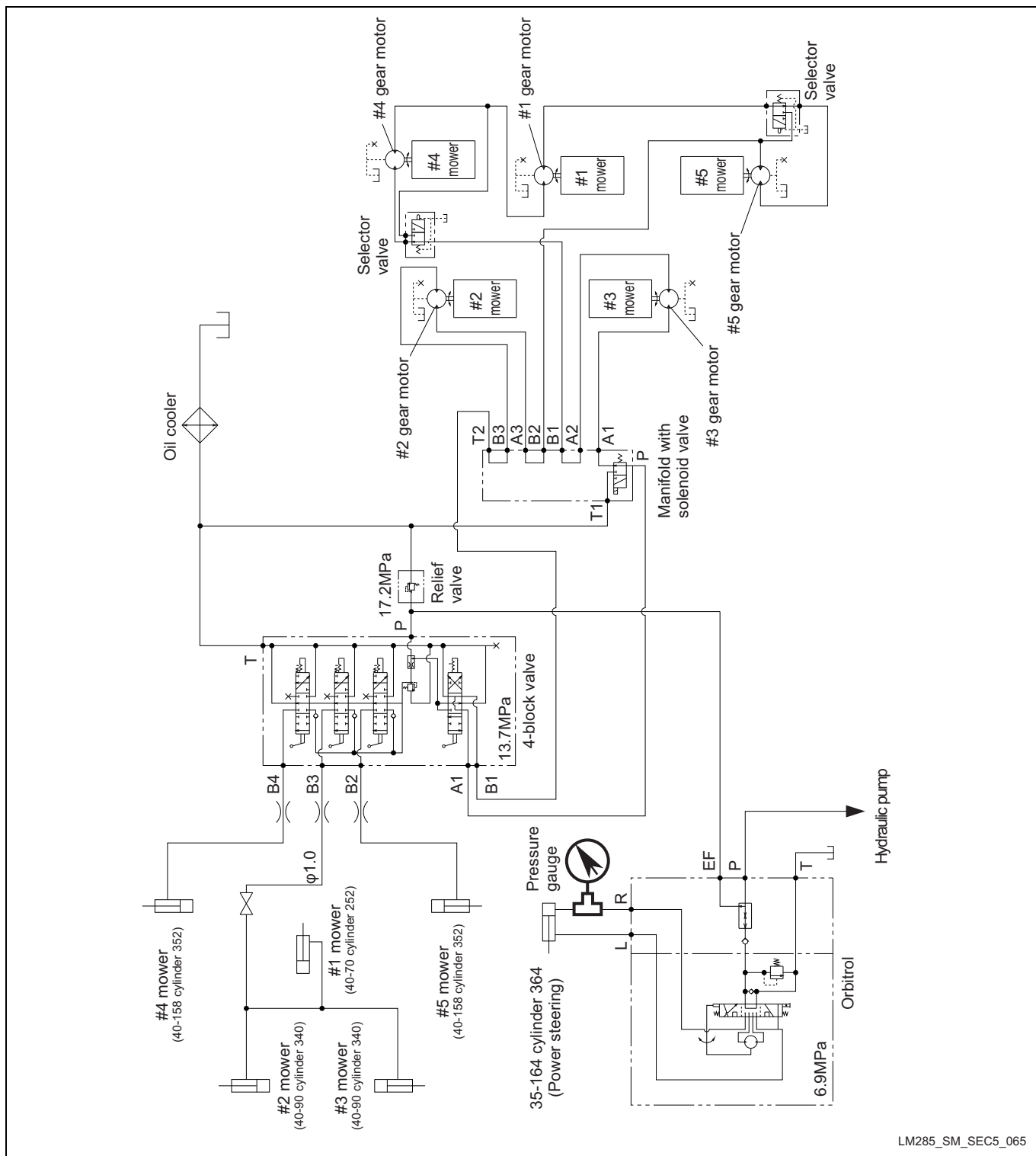

Figure: Hydraulic system-60-a

1. Remove the hydraulic hose (3) from the elbow (2) attached to the cylinder (1).

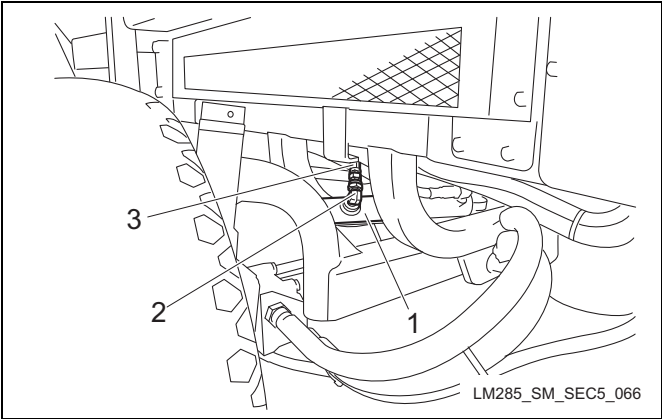

Figure: Hydraulic system-61-a

1	Cylinder
2	Elbow
3	Hydraulic hose

2. Fit the pressure gauge for low-pressure measurement (2) to the removed hydraulic hose (1).
3. Fit the hose of pressure gauge (3) to the elbow (4).

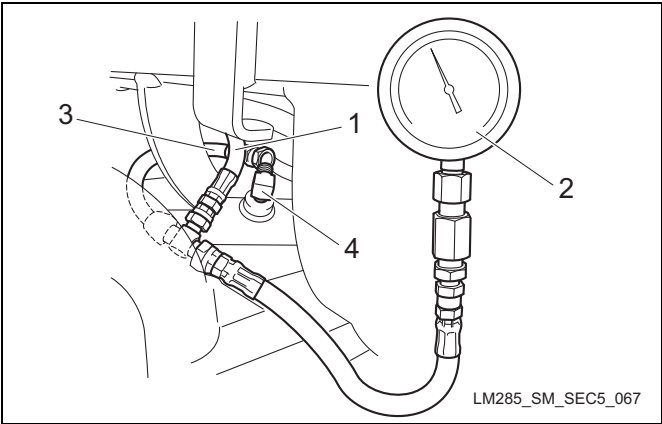

Figure: Hydraulic system-62-a

1	Hydraulic hose
2	Pressure gauge for low-pressure measurement
3	Hose of pressure gauge
4	Elbow

4. Start the engine, turn the steering wheel fully to the left and accelerate to max. rpm. The pressure is considered normal if the pressure gauge reads 6.9MPa (1,000.76 psi).

Hydraulic system

Charge circuit

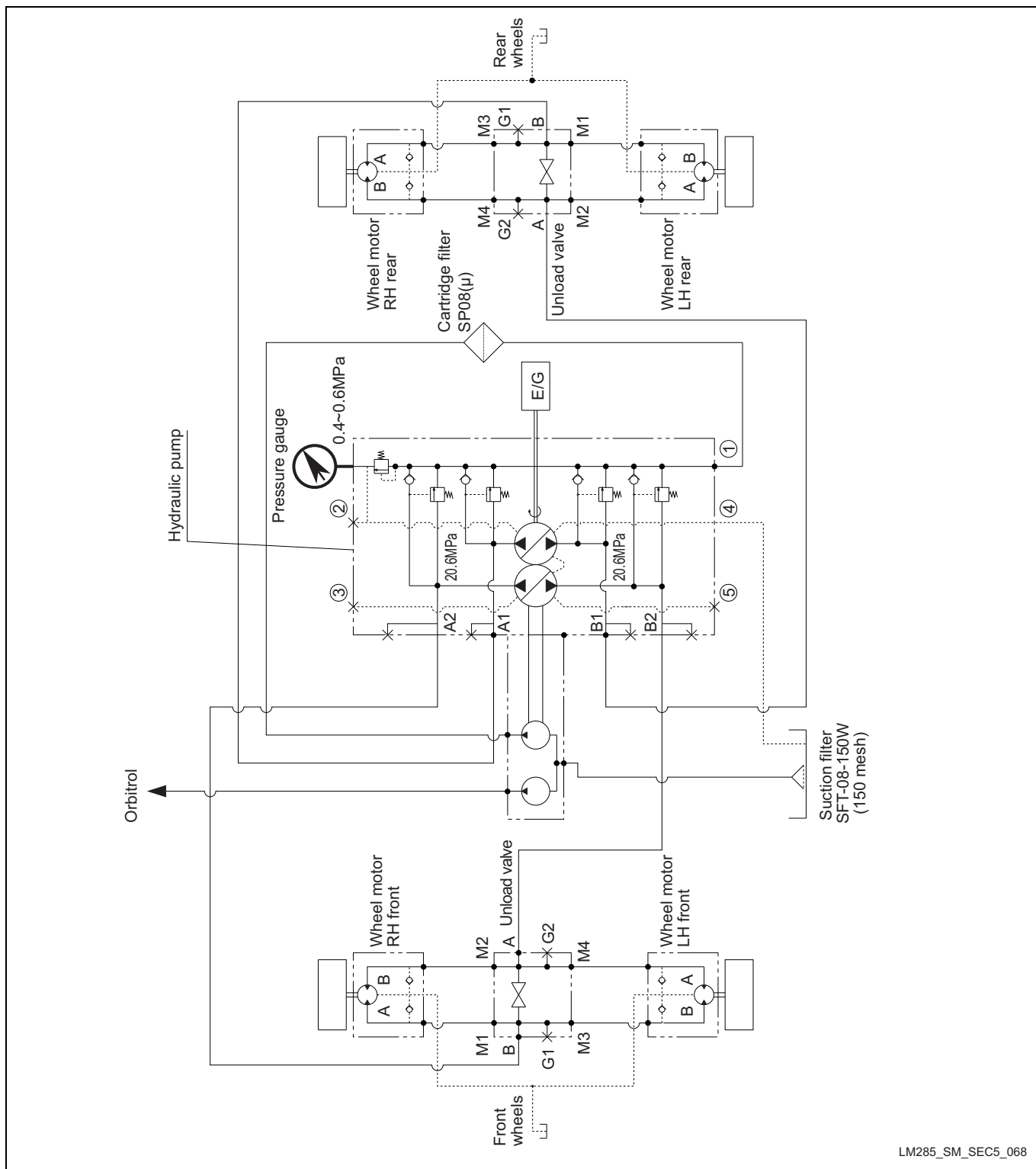

1. Remove the plug (2) of the piston pump (1).

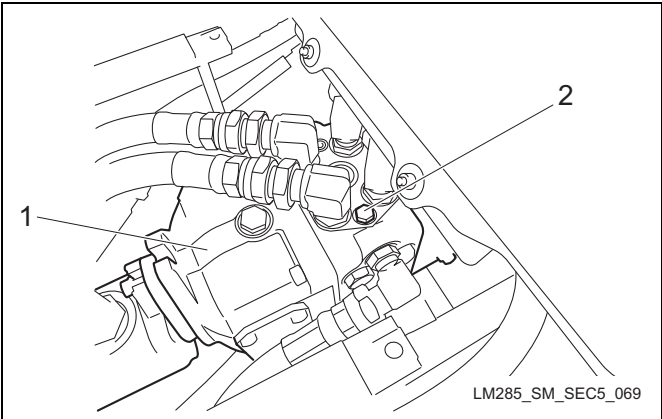

Figure: Hydraulic system-64-a

1	Piston pump
2	Plug

2. Attach the adapter (2) to the piston pump (1) and fit the pressure gauge for ultralow-pressure measurement (3).

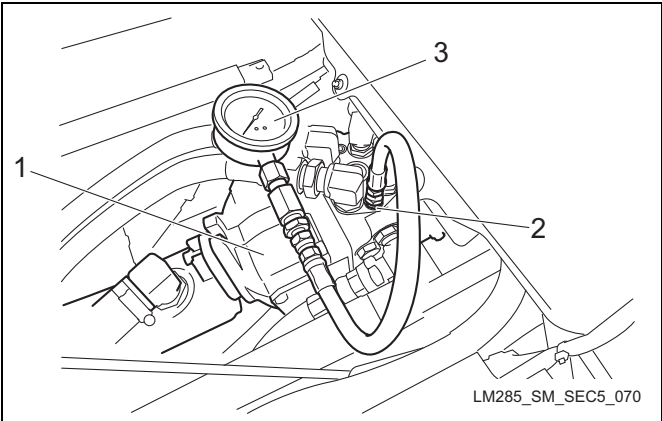

Figure: Hydraulic system-65-a

1	Piston pump
2	Adapter
3	Pressure gauge for ultralow-pressure measurement

3. Start the engine and accelerate to the maximum speed. The pressure is considered normal if the pressure gauge reads 0.4 to 0.6MPa (58.02 to 87.02 psi).

Hydraulic system

Reel rotation circuit

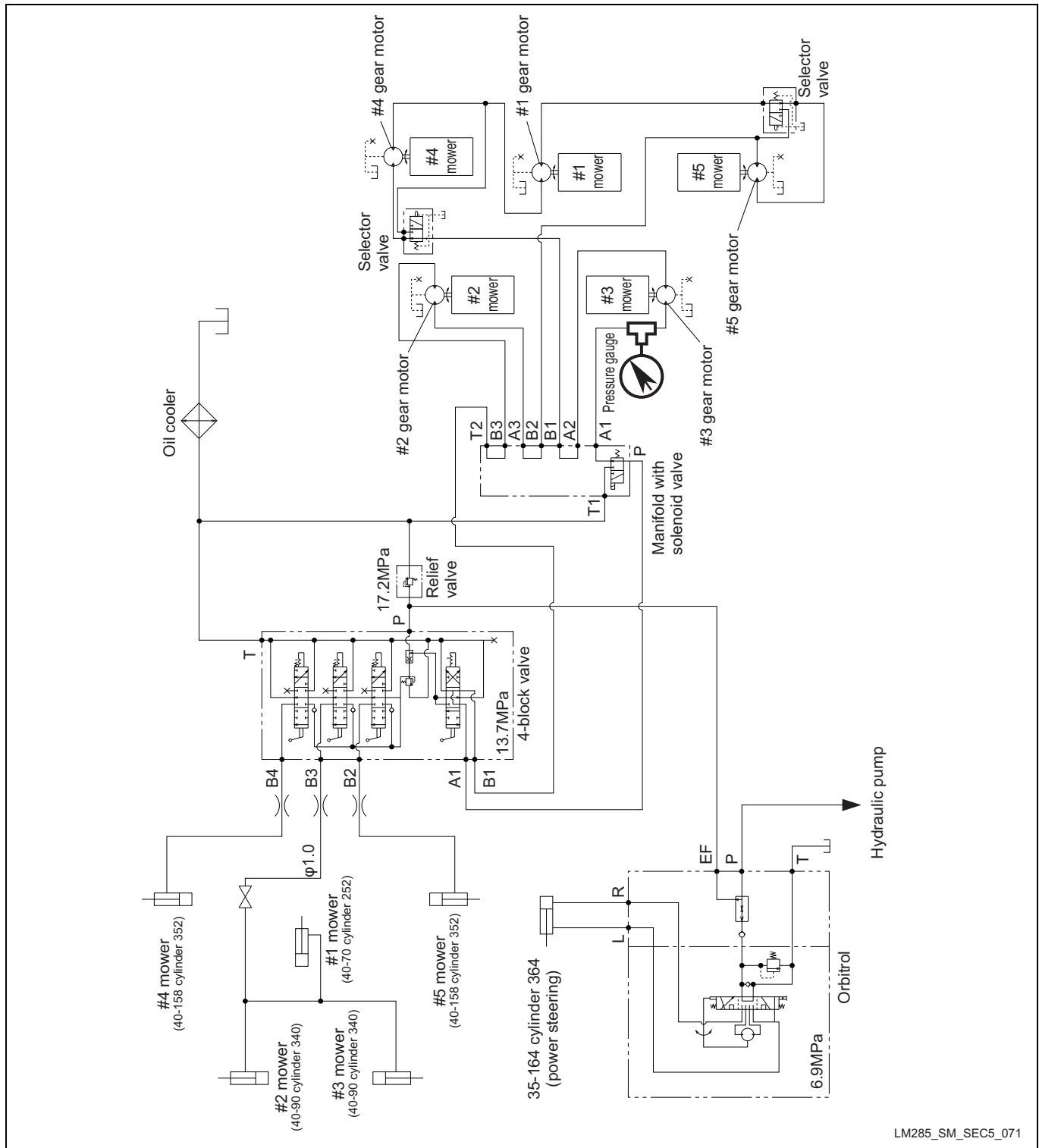

Figure: Hydraulic system-66-a

1. Lower the mower units and remove the hydraulic hose (3) from the elbow (2) of the gear motor (1).

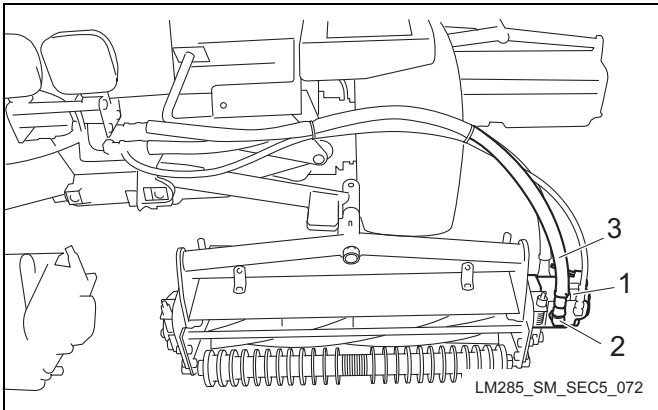

Figure: Hydraulic system-67-a

1	Gear motor
2	Elbow
3	Hydraulic hose

2. Fit the pressure gauge for high-pressure measurement (2) to the removed hydraulic hose (1).
3. Fit the hose of pressure gauge (5) to the elbow (4) of the gear motor (3).
4. Lock the reel cutter firmly with a hard lumber (6) or the like.

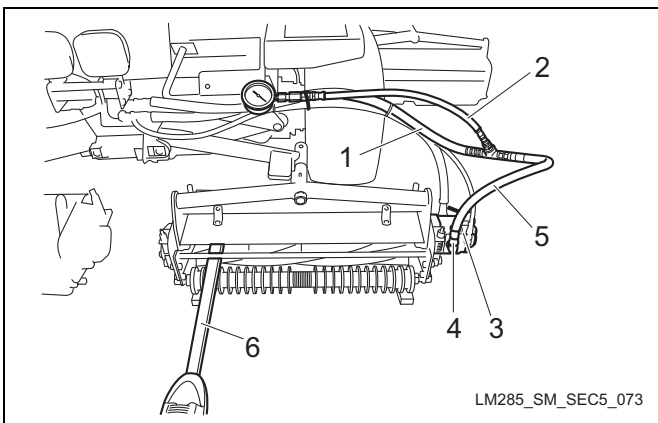

Figure: Hydraulic system-68-a

1	Hydraulic hose
2	Pressure gauge for high-pressure measurement
3	Gear motor
4	Elbow
5	Hose of pressure gauge
6	Lumber

5. Start the engine and accelerate to the maximum speed. Hold the lumber or the like firmly and shift the reel rotation lever to FORWARD side. The pressure is considered normal if the pressure gauge reads 17.2MPa (2,494.65 psi).

Adjustment

Selector valve

Adjustment of selector valve cam

In the case of raising #4 and/or #5 mower unit during the reel cutter rotating, the reel cutter is supposed to stop when the cutting edge of reel cutter and bedknife is lifted more than 400mm (15.75 in). Make an adjustment unless it stops under the condition.

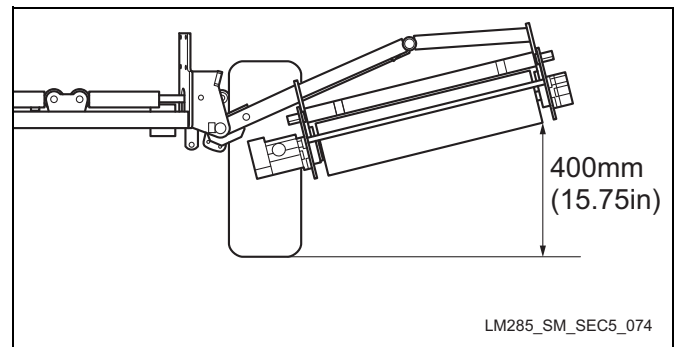

Figure: Hydraulic system-69-a

1. Loosen the bolt (4) and adjust the selector valve cam (3) so that the reel cutter can stop when the cutting edge of reel cutter and bedknife is lifted more than 400mm (15.75 in).
2. Exercise care in the adjusted state and tighten the bolt (4).

Reference: You may temporarily set the bolt at the center of elongate hole of the selector valve cam in the beginning of this adjustment work.

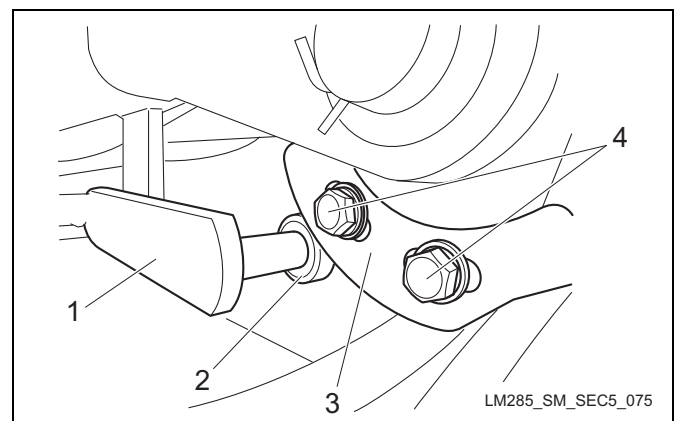

Figure: Hydraulic system-70-a

1	Unload lever
2	Bearing
3	Selector valve cam
4	Bolt

Hydraulic system

General inspection and repair

Note

Before inspection and repair

1. Move the machine to a level place. Apply the parking brake and lower the rake. Then, stop the engine and remove the key.
2. Clean the machine. Be sure to clean parts such as the piping, hoses, and hydraulic fittings. Remember that cleaning is always necessary upon inspection and repair of hydraulic systems.

Warning

Be sure to depressurize the hydraulic system before inspecting and repairing it.

3. When piping and hoses are removed, put a cap or plug in its place to prevent contamination of the hydraulic systems.
4. Attach labels or other identifications to the removed piping and hoses so that they can be correctly refitted.
5. When removing piping and hoses, pay special attention to the connection part. If necessary, mark the piping and hoses to ensure correct fitting.

After inspection and repair

Caution

Check to see if there is any hydraulic oil leakage in each part after installation. Refer to the tightening torque list. We are not responsible for failure due to abnormal tightening, excessive torque tightening and so on.

1. Check the amount of oil in the hydraulic tank and fill if necessary. In the event that failure or contamination is found in the hydraulic circuit, replace the hydraulic oil and filter.
2. When fitting hydraulic fittings, apply hydraulic oil onto the O ring and seal.
3. Fit hoses and hydraulic fittings only after removing the cap and plug.
4. When fitting hoses and hydraulic fittings, follow the proper procedure for tightening.
5. After repair, check to see whether the hydraulic system functions normally and whether there are any broken parts.

6. When the hydraulic system has been repaired or replaced, operate the machine slowly, idling the engine, to allow the air to go out of the circuit.
7. Check to see if there is any oil leakage. In the event of leakage, stop the engine, set the oil stopper, and check the amount of oil in the hydraulic tank. Add oil if necessary.

Hydraulic hose, piping

Warning

When checking for pinhole leakage of the hydraulic circuit or oil leakage of the nozzle, search for a leakage point using something like paper or cardboard, never with your bare hands. Be careful about high-pressure oil which may pierce your skin, resulting in physical injury.

Check the piping and hose every day for oil leakage, damage to the circuit, looseness, abrasion, loosening of connecting part, weatherrelated deterioration and chemical-related deterioration. If necessary, repair before operating the machine.

Hydraulic oil

Important

In the event of hydraulic circuit failure, be sure to clean the circuit.

In the event of contamination or failure of the hydraulic circuit, clean and/or replace the parts.

Since the hydraulic circuit is closed, any contaminant will remain within the circuit and may lead to other failures unless cleaned.

Caution

Exercise adequate care since hot oil adhered to your skin can cause burn injury.

1. Drive and maneuver the machine and warm up the hydraulic oil.
2. Move the machine to a level place. Apply the parking brake and lower the rake. Then, stop the engine and remove the key.

Warning

Be sure to depressurize hydraulic systems before inspecting and repairing them.

Important

Be sure to clean the circuit connecting part to be repaired.

3. Drain the oil from the hydraulic tank.
4. Drain the oil from the hydraulic hoses and piping while the oil is still warm.
5. Replace the hydraulic oil and filter.
6. Check the hydraulic tank and clean.
7. Fit the hydraulic hoses, piping and hydraulic fittings that have been removed.

Caution

Use only the specified hydraulic oil. Use of other hydraulic oil may lead to the failure of hydraulic circuit or the like of.

8. Supply new hydraulic oil.
9. Check to confirm that the forward/reverse pedals and all the drives of the operating machine are in the neutral position.
10. Start and run the engine for 10 seconds to see if there is any oil leakage, etc. Repeat this procedure.
11. Start the engine and let it run idle for at least two minutes, then run at the maximum speed for one minute.
12. Raise and lower the the rake, and turn the steering wheel side to side.
13. Stop the engine and check to see if there is any oil leakage. Check the amount of hydraulic oil and fill if necessary.
14. Operate for two hours under normal operating conditions.
15. Check the condition of hydraulic oil. If it is contaminated, repeat the procedures from 1 through 13 until the oil becomes clean.
16. If no abnormality is found, operate normally and maintain according to the maintenance schedule.

Bleeding

Caution

Whenever the motor, pump, cylinder or the like of is replaced or repaired, check to see that the hydraulic system is properly connected. Be sure to bleed in order to prevent failures.

Important

Whenever hydraulic parts are replaced or repaired, replace the oil filter.

1. Move the machine to a level place. Apply the parking brake and lower the rake. Then, stop the engine and remove the key.
2. Check to see that the hydraulic equipment and hydraulic fittings are securely fastened.
3. In the event of failure or contamination of hydraulic system, clean the hydraulic system and hydraulic tank, and replace the hydraulic oil.
4. Check the amount of hydraulic oil and fill if necessary.
5. Adjust and connect properly, and check for damage to parts or leakage of oil.
6. Check to see that the forward/reverse pedals and all the drives of the operating machine are in the neutral position.
7. Start and run the engine for 10 seconds and check for oil leakage or the like of. Repeat this procedure once again.

Warning

When jacking up the machine, check the “Jacking up the machine” (Page 1-5)

8. Jack up all the wheels of the machine and support securely with a jack stand or proper block.
9. Check to see that the forward/reverse pedals and all the drives of the operating machine are in the neutral position.
10. Start the engine and slightly depress the forward/reverse pedal. The charge pump will purge the air from the hydraulic system in 30 seconds or so, and the circuit will be primed for operation.
11. As soon as the oil begins to fill the hydraulic circuit, maneuver the raise/lower lever and the switch to operate the raise/lower cylinder several times. In the

Hydraulic system

event that the cylinder does not operate in 10 to 15 seconds or the pump makes an abnormal noise, stop the engine immediately and investigate the cause. Then, proceed with the following inspection.

- [1] Looseness/failure of filter or suction line
 - [2] Looseness/failure of pump coupler
 - [3] Clogging of suction line
 - [4] Clogging of charge relief valve
 - [5] Failure of charge pump
12. If the raise/lower cylinder operates in 10 to 15 seconds, proceed to the next step.
 13. Maneuver the forward/reverse pedals and check to see if the wheel rotates in proper direction.
 - [1] If the wheel rotates in the wrong direction, stop the engine and switch the motor line to modify the rotation direction.
 - [2] If the rotation direction is correct, stop the engine.
 14. Return the forward/reverse pedals to the neutral position.
 15. Check the neutrality of traveling and adjust. (Refer to Owner's operating manual.)
 16. Lower the machine to the ground.
 17. If the traveling pump or wheel motor is removed, proceed with the following operation.
 - [1] Operate for 10 minutes and let the wheel rotate slowly.
 - [2] In the following 10 minutes, drive with the workload being gradually increased.
 - [3] Stop the machine, check the amount of hydraulic oil, and fill the oil if necessary. Check for oil leakage. Check every connection part thoroughly.
 - [4] Check the neutrality of traveling. If adjustment is needed, jack up all the wheels of the machine and support securely with a jack stand or proper block.

Inspection and repair of each section

Hydraulic oil

Inspection of hydraulic oil

1. On a level surface, on the condition of raising mower units, check to see if the hydraulic oil is up to the center of the oil gauge (1). Replenish oil as appropriate.
2. Check underneath the machine body for oil leakage.

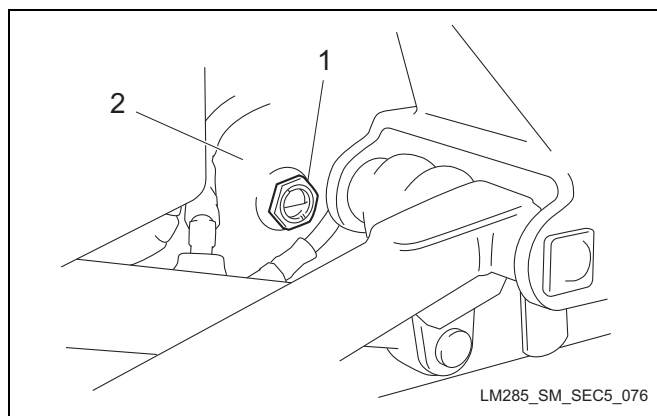

Figure: Hydraulic system-71-a

1	Oil gauge
2	Hydraulic tank

Change of hydraulic oil

Caution

If hydraulic oil has emulsified or lost any of its clarity, change immediately.

Contamination of hydraulic oil leads to the failure of hydraulic equipment. Change hydraulic oil regularly. Change period First time After 100 hours of operation

Change	period First time	After 100 hours of operation
	From the second time onward	For every 500 hours of operation
Specified hydraulic oil	Shell Tellus 46 (Equivalent)	
Capacity of hydraulic tank	24 L (63.4 US gallons)	

1. Start the engine to warm up the oil, and remove the drain plug (2) of the hydraulic tank (1) on a level place to drain the old hydraulic oil.

- Rewind a new seal tape around the drain plug (2) and reattach the plug onto the hydraulic tank (1).

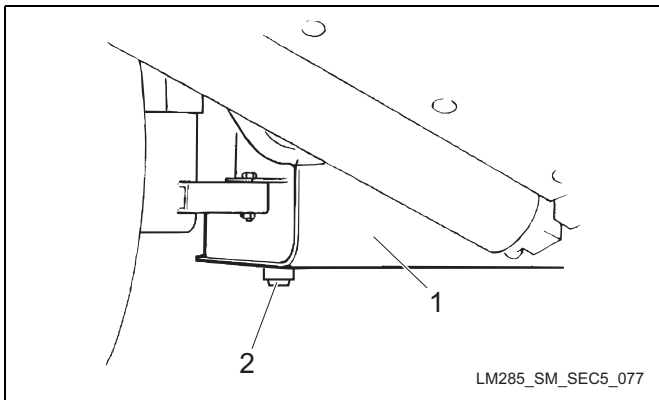

Figure: Hydraulic system-72-a

1	Hydraulic tank
2	Drain plug

- Remove the tank cap (1), add new hydraulic oil from the fill port till the oil surface reaches the center of the oil gauge of the hydraulic tank and fit the tank cap (1).

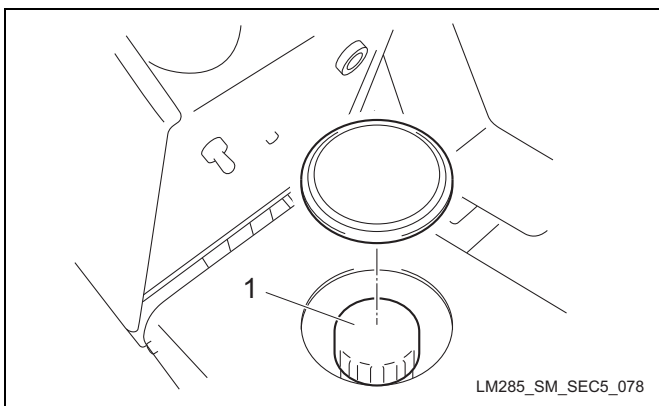

Figure: Hydraulic system-73-a

1	Tank cap
---	----------

- Start the engine, raise/lower the mower units and turn the steering wheel from side to side. Repeat traveling forward and reverse several times.
- Check to see if the oil surface is in the center of the oil gauge and replenish as appropriate.

Hydraulic oil filter

Change of hydraulic oil filter

Contamination of the hydraulic oil causes a failure of the hydraulic equipment. Change the hydraulic oil filter regularly.

Change period	First time	After 100 hours of operation
	From the second time onward	For every 500 hours of operation

- Remove the old cartridge filter (1).
- Apply clean hydraulic oil onto the packing of new cartridge filter.
- Screw in the filter by hand till the packing touches the fitting surface. Then, further tighten for 1/2 turn.
- After fitting, start the engine to warm up the oil. Then, stop the engine and check for the leakage of oil.

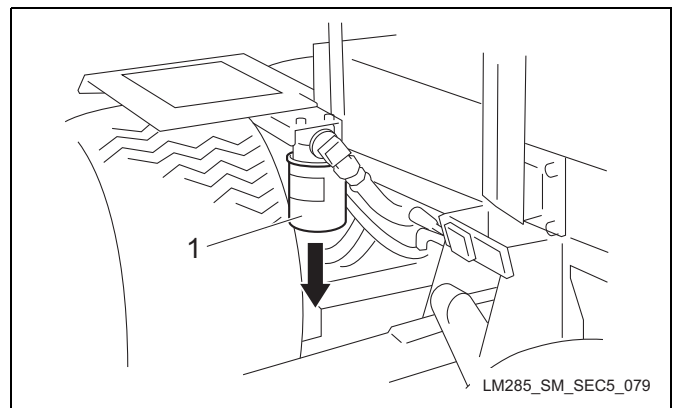

Figure: Hydraulic system-74-a

1	Cartridge filter
---	------------------

Change of suction filter

- Remove the center cover. (Refer to “Removal of center cover” (Page 7-20))

Important

Remember the position and direction of attachment of the hydraulic intake before removal of it.

- Remove the hydraulic intake (1). (Refer to “Removal of hydraulic tank” (Page 5-64))

Hydraulic system

- Remove the old suction filter (2) from the hydraulic intake (1).

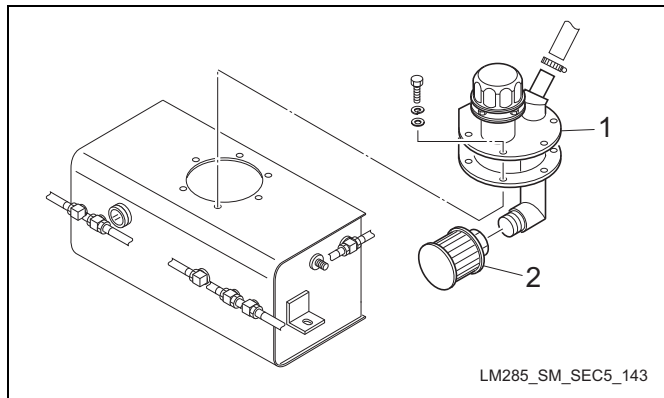

Figure: Hydraulic system-75-a

1	Hydraulic intake
2	Suction filter

Important

Fit the suction filter, exercising care in preventing the filtering area from being damaged.

- Fit the new suction filter to the hydraulic intake.

Important

After fitting, check for hydraulic oil leakage in each section.

Refer to tightening torques reference chart. We are not responsible for defects which occurred due to abnormal or overtorque tightening etc.

- Fit the hydraulic intake and the center cover by the reverse procedure to removal.

Selector valve

Inspection of selector valve cam

Depending on frequency of use, the unload lever bearing and/or the selector valve cam may move slowly and/or the reel cutters may not stop. Inspect them and if necessary, adjust and perform further service.

Important

For adjustment of selector valve, refer to "Selector valve" (Page 5-39).

- Check if the bearing (2) of the unload lever (1) is jerky.

- Check if the selector valve cam (3) is worn.

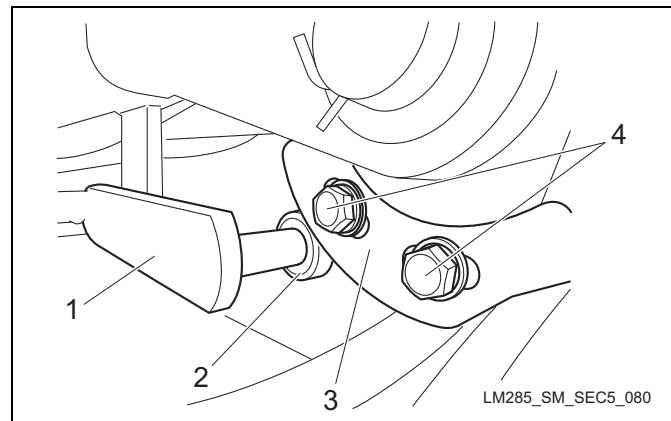

Figure: Hydraulic system-76-a

1	Unload lever
2	Bearing
3	Selector valve cam
4	Bolt

Removal and installation of each section

Piston pump

Removal of piston pump

- Remove the minus side of the battery cable. (Refer to "Battery" (Page 6-19))
- Drain the hydraulic oil. (Refer to "Hydraulic oil" (Page 5-42))
- Remove the seat. (Refer to "Removal of seat" (Page 7-13))
- Remove the underseat cover section. (Refer to "Removal of cover under seat" (Page 7-14))
- Remove the fuel tank. (Refer to "Removal of fuel tank" (Page 7-15))
- Remove the connector (2) of the fuel transfer pump (1).

- Release the pipe clip (4) fastening the fuel transfer pump (1) and the fuel tube (3) and remove the fuel tube (3) from the fuel transfer pump (1).

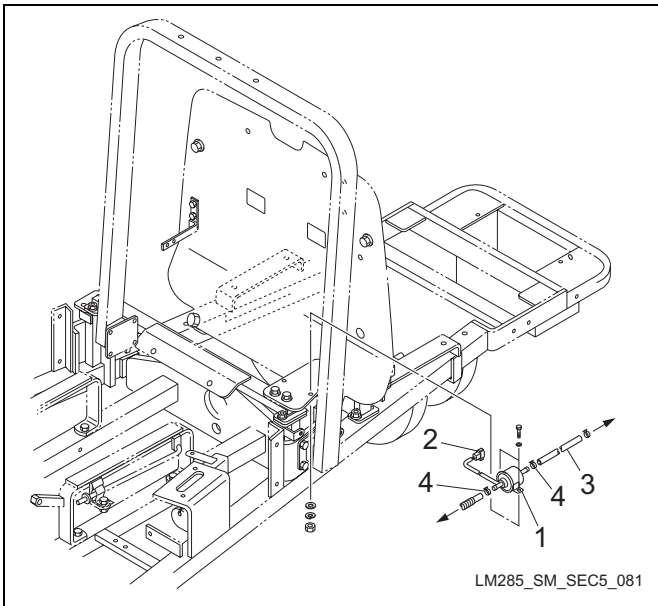

Figure: Hydraulic system-77-a

1	Hydraulic transfer pump
2	Connector
3	Fuel tube
4	Pipe clip

- Open the bonnet and remove the bolts (4), washers (5), nuts (6) and S washers (7) which are fastening the fuel pump mounting plate (1), wind shielding plate (2) and wind shielding plate support (3).

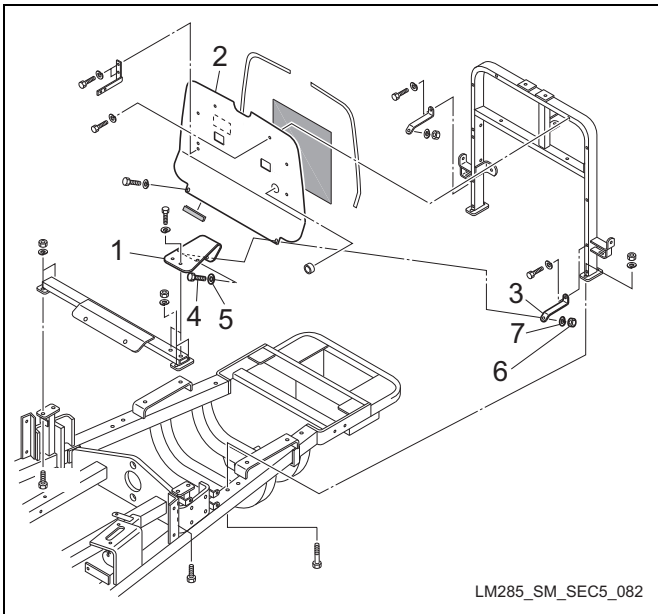

Figure: Hydraulic system-78-a

1	Fuel pump mounting plate
2	Wind shielding plate
3	Wind shielding plate support
4	Bolt
5	Washer
6	Nut
7	S washer

- Remove the bolts (2), nuts (3) and S washer (4) fastening the main body frame and the fuel tank mounting bracket front (1) and remove at the same time the fuel tank mounting bracket front (1) and the fuel pump mounting plate (5).

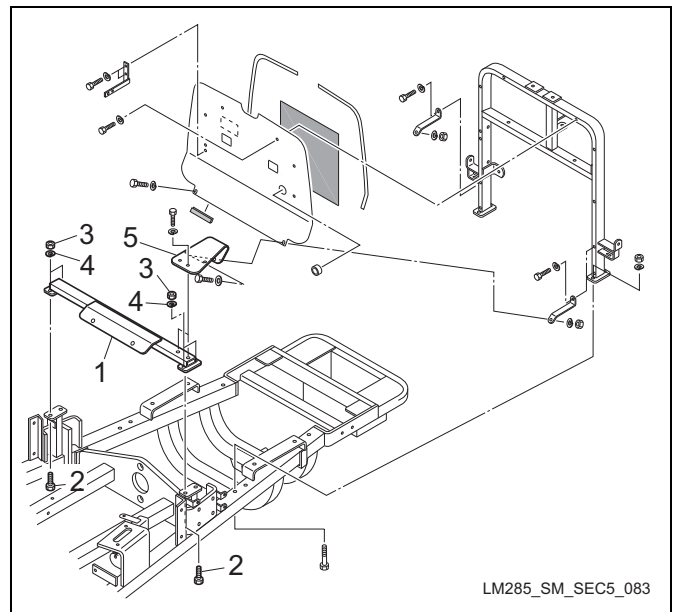

Figure: Hydraulic system-79-a

1	Fuel tank mounting bracket front
2	Bolt
3	Nut
4	S washer
5	Fuel pump mounting plate.

Hydraulic system

10. Remove all the hydraulic hoses (2) attached to the piston pump (1).

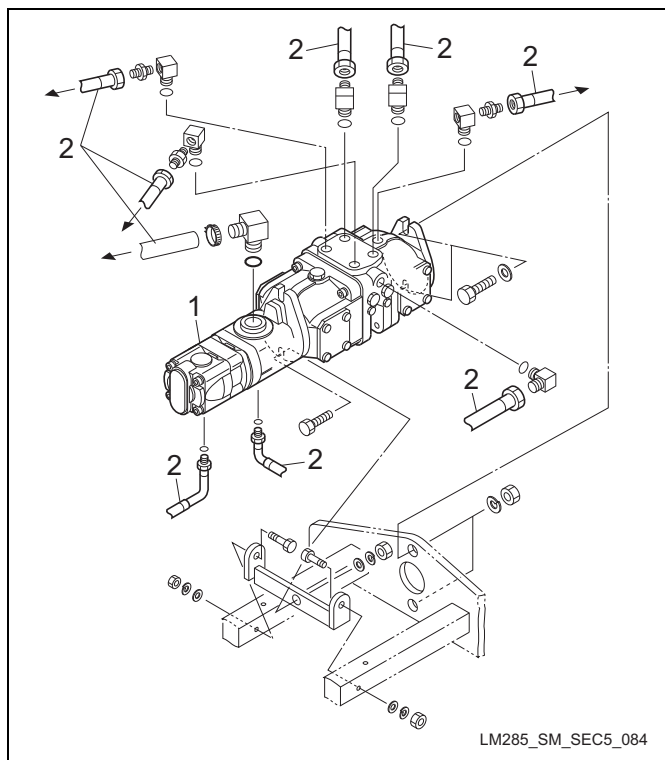

Figure: Hydraulic system-80-a

1	Piston pump
2	Hydraulic hose

11. Remove the nuts (3) and S washers (4) fastening the rod end (1) and shift lever (2).

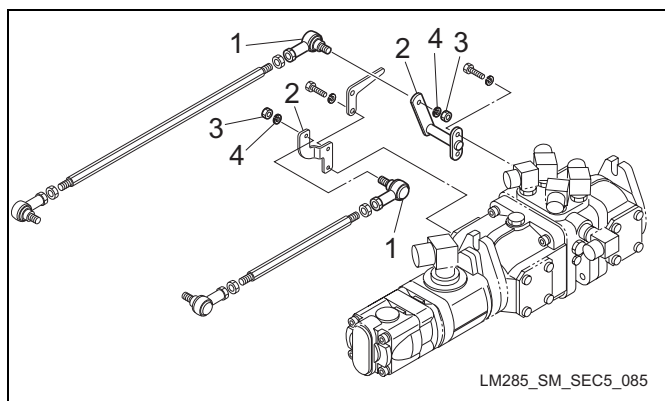

Figure: Hydraulic system-81-a

1	Rod end
2	Shift lever
3	Nut
4	S washer

12. Remove the bolt (3), nut (4), S washer (5) and washer (6) fastening the piston pump (1) and pump support (2).

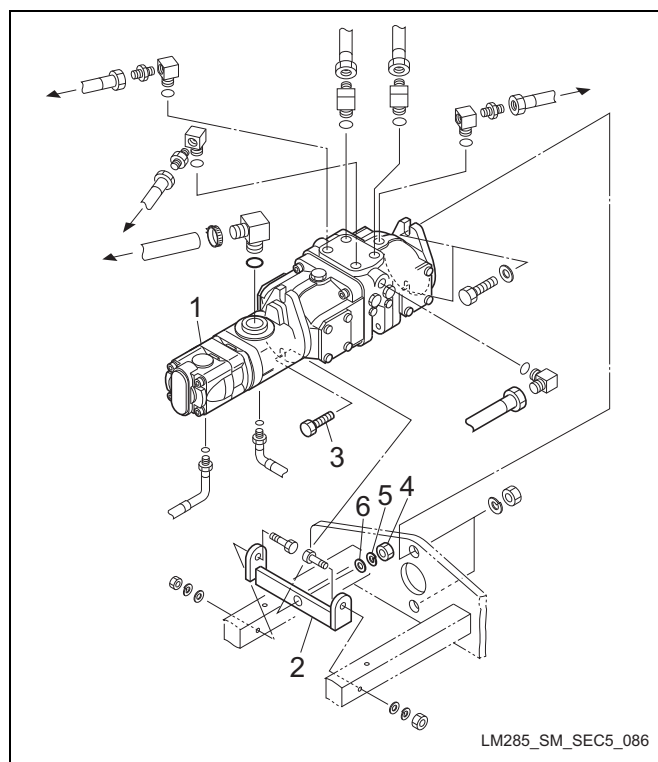

Figure: Hydraulic system-82-a

1	Piston pump
2	Pump support
3	Bolt
4	Nut
5	S washer
6	Washer

13. Remove the bolts (2) and S washers (3) fastening the joint (1) to the engine.

14. Remove the bolts (6), nuts (7) and S washer (8) fastening the spacer (5) and joint (1) to the drive disk (4) of the pump side and remove the spacer (5) and joint (1).

Hydraulic system

15. Loosen the bolt with hexagonal hole (9) and remove the drive disk (4) of the pump side from the spline shaft (10) of the piston pump.

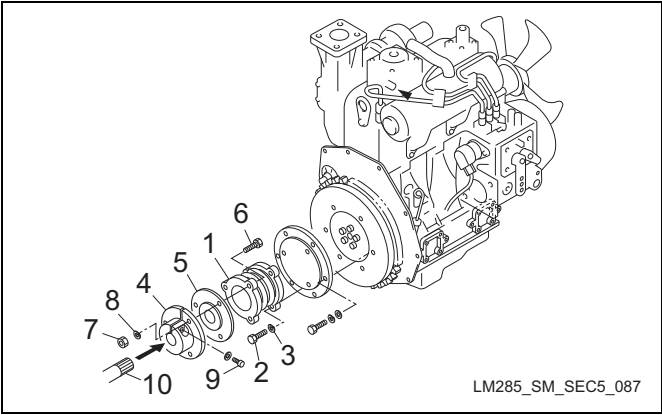

Figure: Hydraulic system-83-a

1	Joint
2	Bolt
3	S washer
4	Drive disk of the pump side
5	Spacer
6	Bolt
7	Nut
8	S washer
9	Bolt with hexagonal hole
10	Spline shaft

16. Remove the bolts (2), washers (3), nuts (4) and S washers (5) fastening the piston pump (1) to the frame.

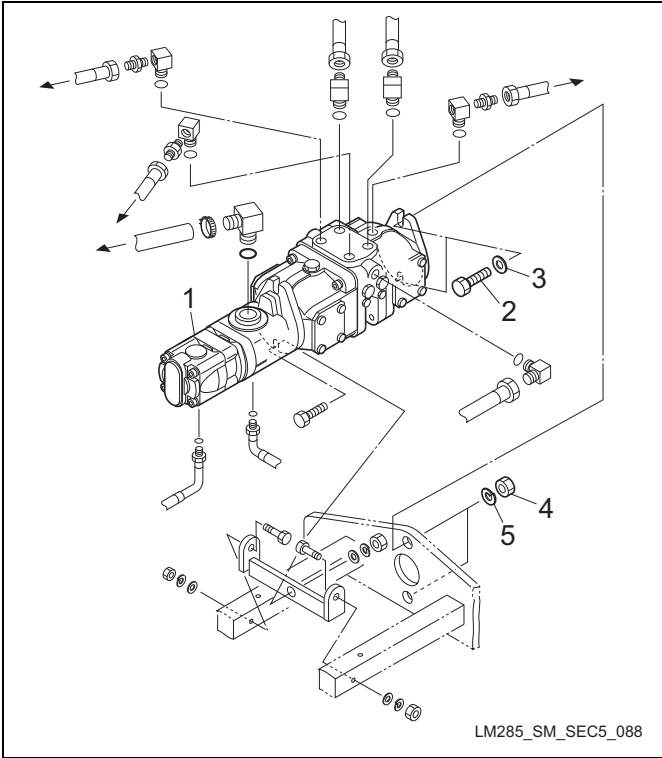

Figure: Hydraulic system-84-a

1	Piston pump
2	Bolt
3	Washer
4	Nut
5	S washer

17. Remove the piston pump (1) from the main body.
 18. Remove the bolts (2) and S washers (3) from the removed piston pump (1) and remove the shift lever (4) and neutral lever (5).

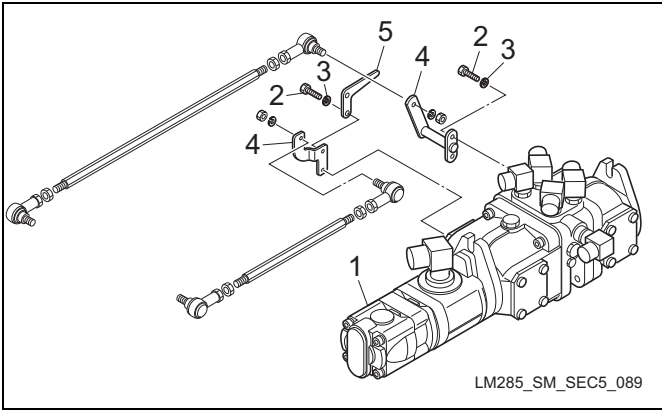

Figure: Hydraulic system-85-a

Hydraulic system

1	Piston pump
2	Bolt
3	S washer
4	Shift lever
5	Neutral lever

19. Remove the adapters (1) and remove in order the elbow A (2) and O ring A (3), elbow B (4) and O ring B (5), elbow C (6) and O ring C (7) and elbow D (8) and O ring D (9).

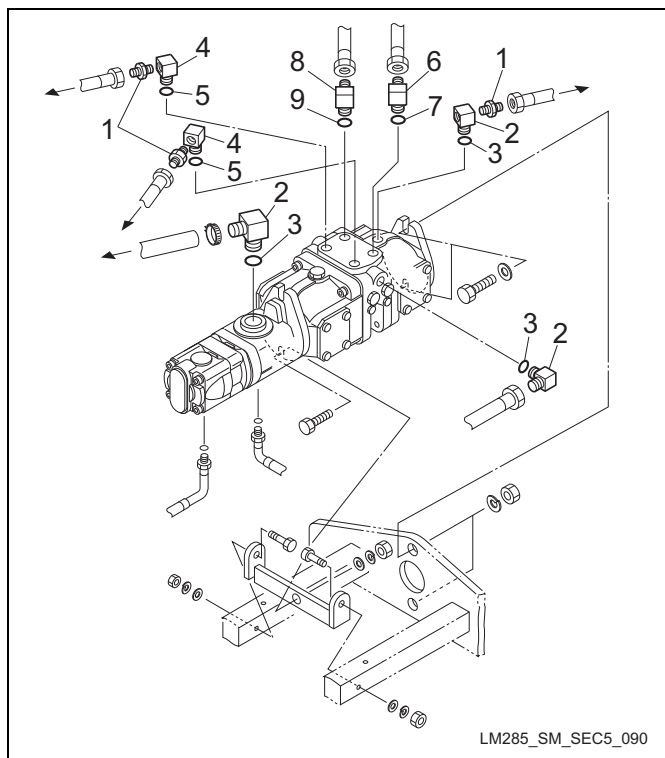
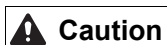

Figure: Hydraulic system-86-a

1	Adapter
2	Elbow A
3	O ring A
4	Elbow B
5	O ring B
6	Elbow C
7	O ring C
8	Elbow D
9	O ring D

Installation of piston pump



Exercise care in the direction of the joint.

Caution

After fitting, check for hydraulic oil leakage in each section.

Refer to the tightening torques reference chart. We are not responsible for defects which occurred due to abnormal or overtorque tightening etc.

For installation, reverse the removal procedures.

4-block valve

Removal of 4-block valve

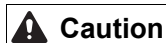

Work in a twosome due to the heavy 4- block pump.

1. Lower all the mower units with the raise/lower levers (1).
2. Remove the minus side of the battery cable. (Refer to "Battery" (Page 6-19))
3. Remove the seat. (Refer to "Removal of seat" (Page 7-13))
4. Remove the underseat cover section. (Refer to "Removal of cover under seat" (Page 7-14))
5. Remove the grips (3) of the raise/lower levers (1) and reel rotation lever (2).
6. Loosen the knob (4) of the reel reverse rotation stopper and slide it to the position of "FOR BACKLAPPING"(Lapping).
7. Remove the bolts (6) of the hand support right (5).
8. Remove the bolts (8) of the front cover right (7).

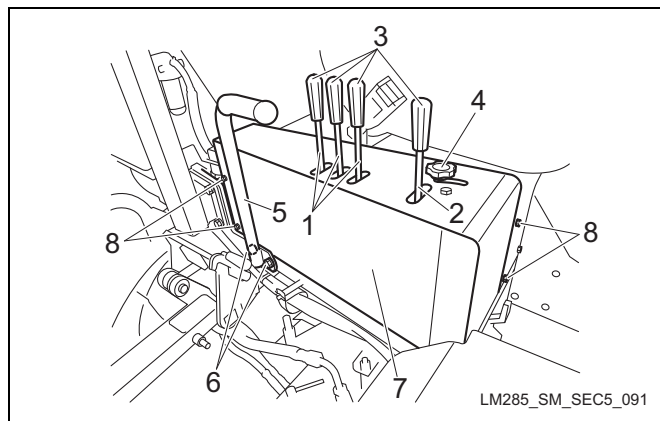

Figure: Hydraulic system-87-a

1	Raise/lower lever
2	Reel rotation lever
3	Grip
4	Knob
5	Hand support right
6	Bolt
7	Front cover right
8	Bolt

Important

When removing the end terminals, confirm the colors of the wirings.

9. Draw out the front cover right (1) slowly and remove the end terminals (3) of the limit switch (2) attached to the front cover right.

Important

When removing the connectors, confirm the colors of the wirings.

10. Remove the connectors (6) of the limit switches (5) of the reel rotation lever (4).
11. Remove the bolts (8) of the switch mounting plate (7) and remove the limit switches (5).

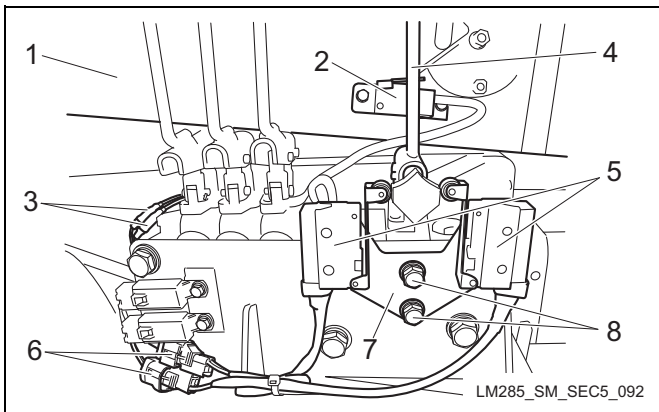

Figure: Hydraulic system-88-a

1	Front cover right
2	Limit switch
3	End terminal
4	Reel rotation lever
5	Limit switch
6	Connector
7	Switch mounting plate
8	Bolt

12. Remove the split pins (1) and washers (2) and draw out the pins (3).

13. Remove the raise/lower levers (4) and reel rotation lever (5).

Important

When removing the hydraulic hoses, confirm the positions of installation.

14. Remove all the hydraulic hoses (6).

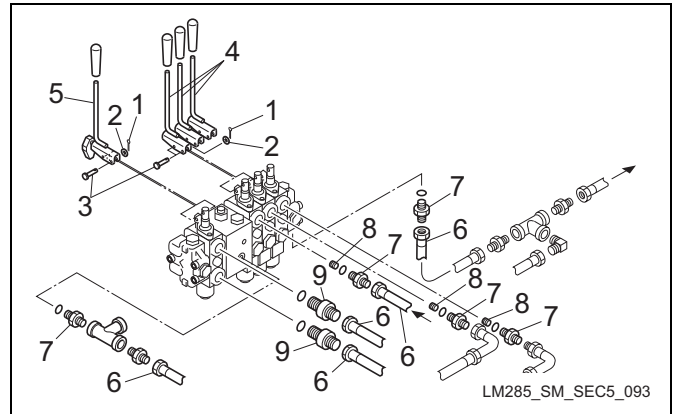

Figure: Hydraulic system-89-a

1	Split pin
2	Washer
3	Pin
4	Raise/lower lever
5	Reel rotation lever
6	Hydraulic hose
7	Connector
8	Plug
9	Adapter

15. Remove the bolts (2) fastening the 4-block valve (1) and remove the 4-block valve.

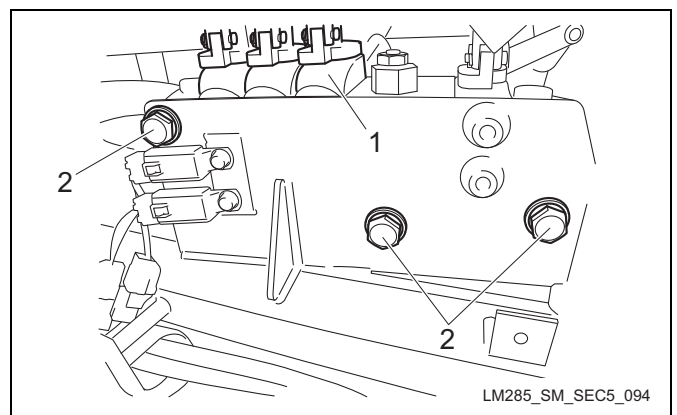

Figure: Hydraulic system-90-a

1	4-block valve
2	Bolt

Hydraulic system

16. Remove the connectors (7) and then remove the plugs (8). (See Figure: Hydraulic system-89-a)
17. Remove the adapters (9). (See Figure: Hydraulic system-89-a)

Installation of 4-block valve

⚠ Caution

After fitting, check for hydraulic oil leakage in each section.

Refer to the tightening torques reference chart. We are not responsible for defects which occurred due to abnormal or overtorque tightening etc.

For installation, reverse the removal procedures.

Adjust the limit switch of the reel rotation lever. (Refer to "Reel rotation switch" (Page 6-9))

Gear motor

Removal of gear motor

■ #1, #4, #5 mower

1. Lower all the mower units with the raise/lower levers.
2. Remove the hydraulic hoses (1) from the adapters (2) and the elbows (3).
3. Remove the adapters (2) from the elbows (3).
4. Remove the elbows (3) from the gear motor (4).
5. Remove the bolts (6), S washers (7) and washers (8) fastening the gear motor (4) to the hydraulic motor housing (5).
6. Remove the gear motor (4) from the hydraulic motor housing (5).

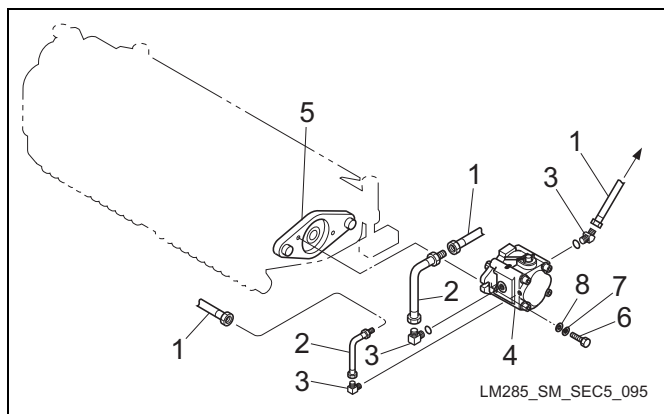

Figure: Hydraulic system-91-a

1	Hydraulic hose
2	Adapter
3	Elbow
4	Gear motor
5	Hydraulic motor housing
6	Bolt
7	S washer
8	Washer

7. Remove the packing (2) from the gear motor (1).

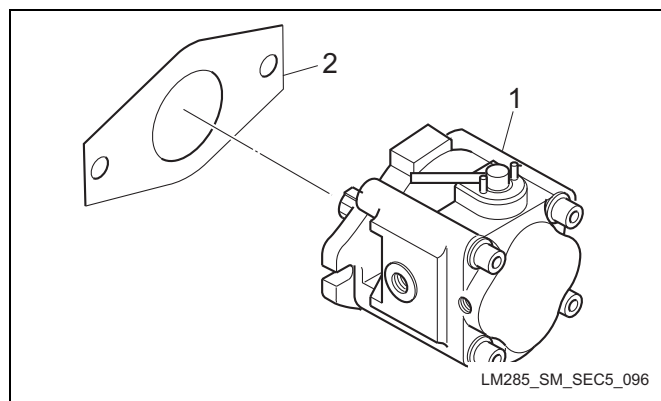

Figure: Hydraulic system-92-a

1	Gear motor
2	Packing

■ #2, #3 mower

1. Lower all the mower units with the raise/lower levers.
2. Remove the hydraulic hoses (1) from the elbows (2).
3. Remove the elbows (2) from the gear motor (3).
4. Remove the bolts (5), S washers (6) and washers (7) fastening the gear motor (3) to the hydraulic motor housing (4).
5. Remove the gear motor (3) from the hydraulic motor housing (4).

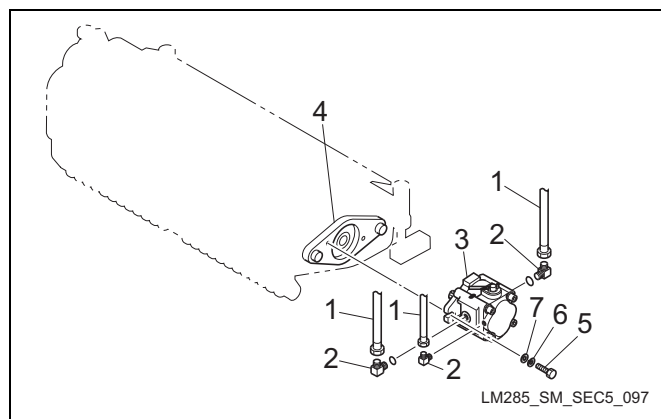

Figure: Hydraulic system-93-a

1	Hydraulic hose
2	Elbow
3	Gear motor
4	Hydraulic motor housing
5	Bolt
6	S washer
7	washer

6. Remove the packing (2) from the gear motor (1).

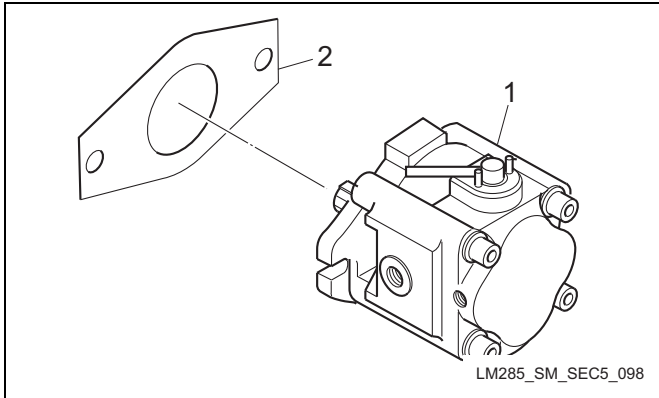

Figure: Hydraulic system-94-a

1	Gear motor
2	Packing

Installation of gear motor

⚠ Caution

Temporarily tighten the elbows and the hydraulic hoses. After adjusting the elbows' positions so that their ends can point right to the upper direction, tighten them finally.

⚠ Caution

After fitting, check for hydraulic oil leakage in each section.

Refer to the tightening torques reference chart. We are not responsible for defects which occurred due to abnormal or overtorque tightening etc.

For installation, reverse the removal procedures.

Raise/lower cylinder

Removal of raise/lower cylinder

■ #1, #2, #3 mower

⚠ Caution

Exercise care in working due to the heavy hydraulic cylinder.

1. Lower all the mower units with the raise/lower levers.
2. Drain the hydraulic oil. (Refer to "Change of hydraulic oil" (Page 5-42))

Important

When removing the hydraulic hoses, confirm the positions of installation.

3. Remove the hydraulic hoses (1).
4. Remove the split pins (2) and the washers (3) and then remove the cylinder pins (4).
5. While supporting the cylinder (5) with hands, remove the split pin (6) and washer (7) and then remove the pin (8).
6. Remove the cylinder (5) and then remove the elbow (9).

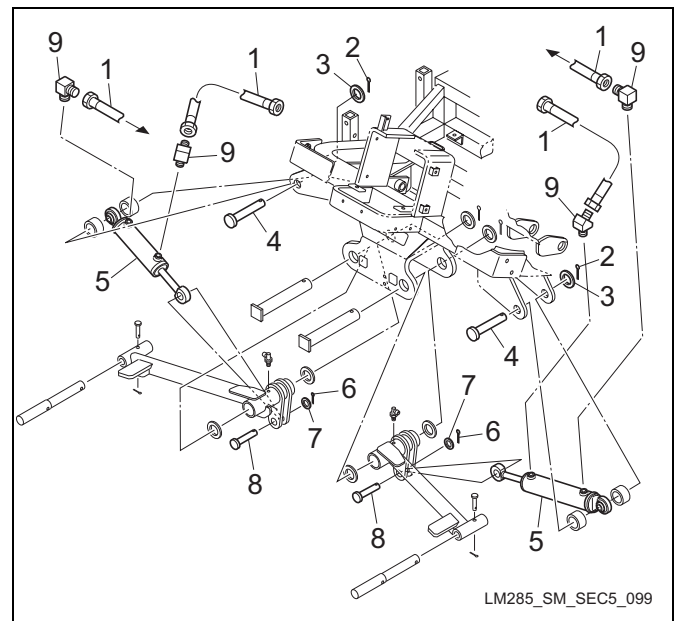

Figure: Hydraulic system-95-a

Hydraulic system

1	Hydraulic hose
2	Split pin
3	Washer
4	Cylinder pin
5	Cylinder
6	Split pin
7	Washer
8	Pin
9	Elbow

■ #4 mower

1. Lower all the mower units with the raise/lower levers.
2. Drain the hydraulic oil. (Refer to “Change of hydraulic oil” (Page 5-42))

Important

When removing the hydraulic hoses, confirm the positions of installation.

3. Remove the hydraulic hoses (1).
4. Remove the split pin (2) and the washer (3) and then remove the cylinder pin (4).
5. While supporting the cylinder (10) with hands, remove the split pin (5) and washer (6) and then remove the pin (7).
6. Remove the cylinders (10).

7. Remove the adapter (8) and the elbows (9).

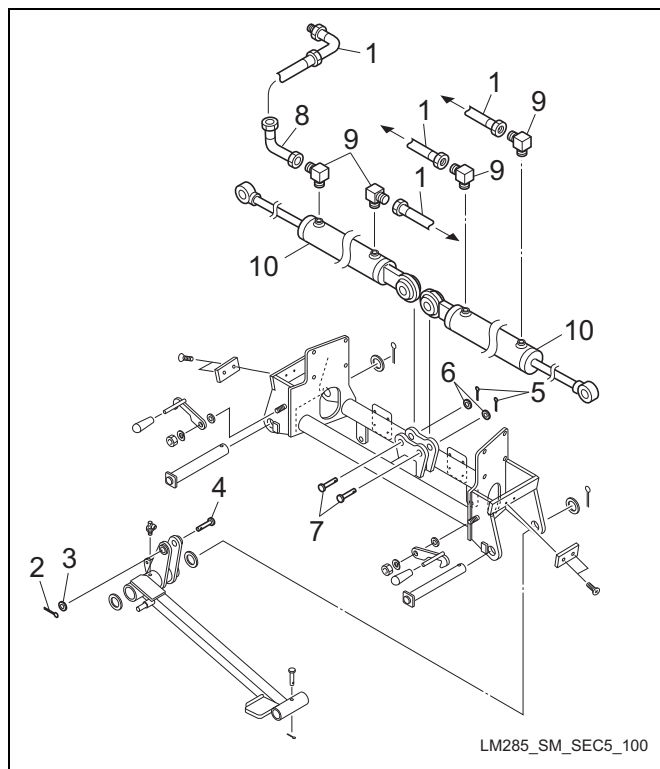

Figure: Hydraulic system-96-a

1	Hydraulic hose
2	Split pin
3	Washer
4	Cylinder pin
5	Split pin
6	Washer
7	Pin
8	Adapter
9	Elbow
10	Cylinder

■ #5 mower

1. Lower all the mower units with the raise/lower levers.
2. Drain the hydraulic oil. (Refer to “Change of hydraulic oil” (Page 5-42))

Important

When removing the hydraulic hoses, confirm the positions of installation.

3. Remove the hydraulic hoses (1).
4. Remove the split pin (2) and the washer (3) and then remove the cylinder pin (4).
5. While supporting the cylinder (10) with hands, remove the split pin (5) and washer (6) and then remove the pin (7).

6. Remove the cylinders (10).
7. Remove the elbows (9).

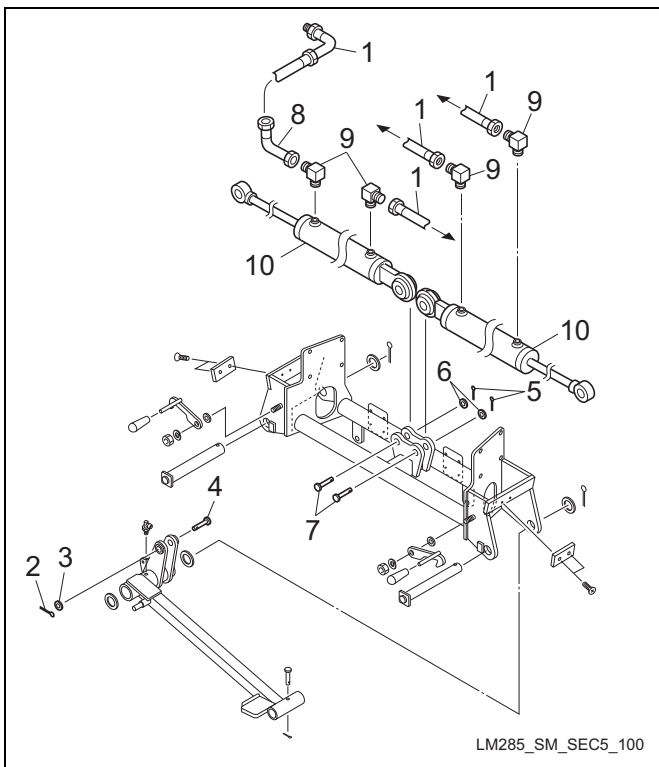

LM285_SM_SEC5_100

Figure: Hydraulic system-97-a

1	Hydraulic hose
2	Split pin
3	Washer
4	Cylinder pin
5	Split pin
6	Washer
7	Pin
8	Adapter
9	Elbow
10	Cylinder

Installation of raise/lower cylinder

Caution

After fitting, check for hydraulic oil leakage in each section.

Refer to the tightening torques reference chart. We are not responsible for defects which occurred due to abnormal or overtorque tightening etc.

For installation, reverse the removal procedures.

Selector valve

Removal of the selector valve on the right side of the machine

Caution

Exercise care in working due to the heavy selector valve.

1. Lower all the mower units with the raise/lower levers.
2. Drain the hydraulic oil. (Refer to “Change of hydraulic oil” (Page 5-42))
3. Remove the nut (2) of the unload lever (1) and draw out the shaft (4) for the stop ring (3) side and remove it.

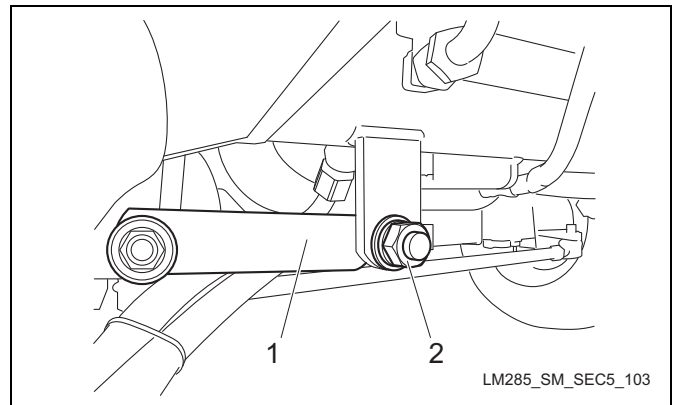

LM285_SM_SEC5_103

Figure: Hydraulic system-98-a

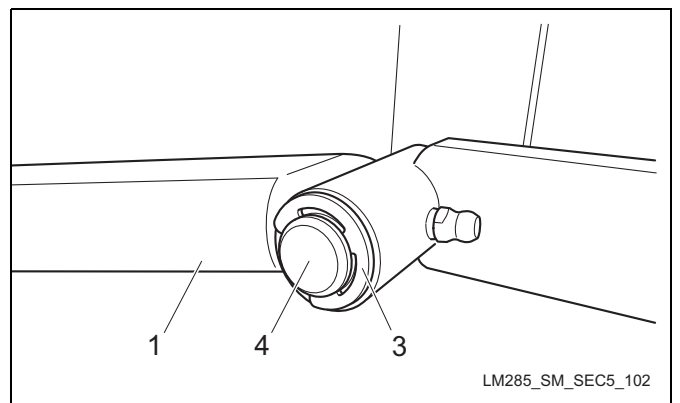

LM285_SM_SEC5_102

Figure: Hydraulic system-99-a

1	Unload lever
2	Nut
3	Stop ring
4	Shaft

4. Remove all the hydraulic hoses (2) attached to the selector valve (1).
5. Remove the bolt (3) fastening the selector valve (1) and remove the selector valve (1).

Hydraulic system

- Remove in order the adapter A (4), the T-shaped connector A (5), the elbow (6), the adapter B (7) and the T-shaped connector B (8).

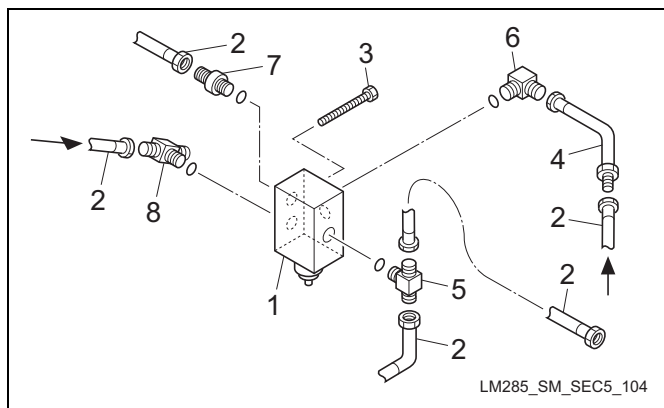

Figure: Hydraulic system-100-a

1	Selector valve
2	Hydraulic hose
3	Bolt
4	Adapter A
5	T-shaped connector A
6	Elbow
7	Adapter B
8	T-shaped connector B

Installation of the selector valve on the right side of the machine

⚠ Caution

Exercise care in working due to the heavy selector valve.

⚠ Caution

After fitting, check for hydraulic oil leakage in each section.

Refer to the tightening torques reference chart. We are not responsible for defects which occurred due to abnormal or overtorque tightening etc.

- Temporarily tighten the T-shaped connector B (8) onto the selector valve (1) and tighten the adapter B (7).
- Temporarily tighten in order the elbow (6), the T-shaped connector A (5) and the adapter A (4).
- Install the selector valve (1) on the main body with the bolts (3).

⚠ Caution

When installing the hydraulic hoses, exercise care in interference.

- Taking care of each angle, tighten the T-shaped connector B (8), the elbow (6), the T-shaped connector A (5) and the adapter A (4).
- Install the hydraulic hoses (2).

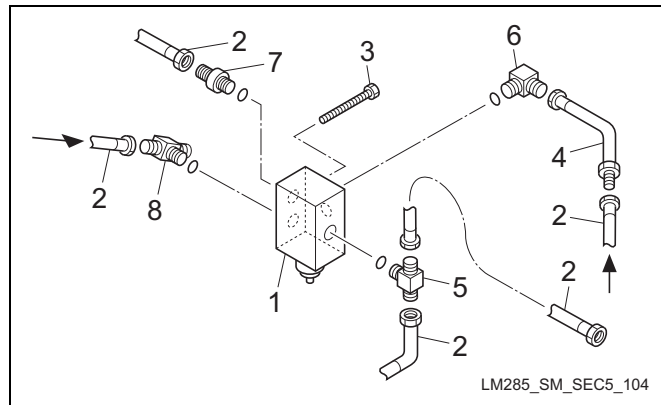

Figure: Hydraulic system-101-a

1	Selector valve
2	Hydraulic hose
3	Bolt
4	Adapter A
5	T-shaped connector A
6	Elbow
7	Adapter B
8	T-shaped connector B

- Apply grease on the shaft (1).
- Insert the bearing (3) in the unload lever (2) and attach the washer (4), the S washer (5) and the nut (6).
- Insert the shaft (1) in the unload lever (2) and install the washer (7) and stop it with the stop ring (8).

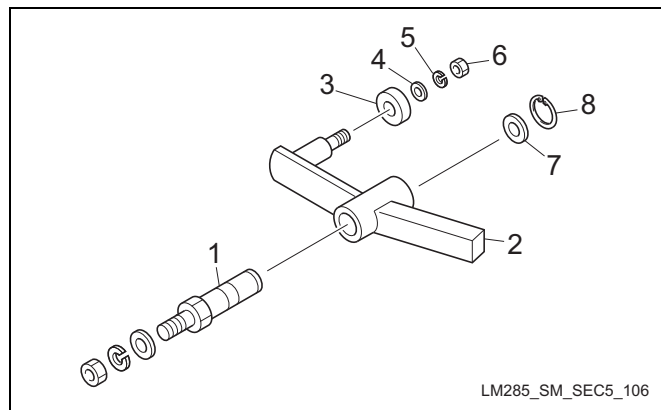

Figure: Hydraulic system-102-a

1	Shaft
2	Unload lever
3	Bearing
4	Washer
5	S washer
6	Nut
7	Washer
8	Stop ring

9. Insert the unload lever (2) in the frame section (1).

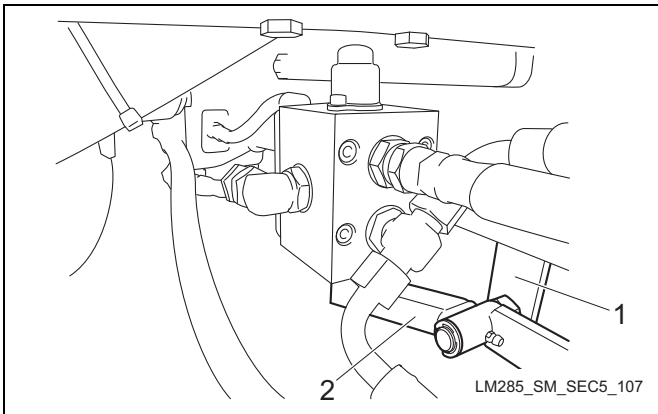

Figure: Hydraulic system-103-a

1	Frame section
2	Unload lever

10. Install the washer (1), the S washer (2) and the nut (3).

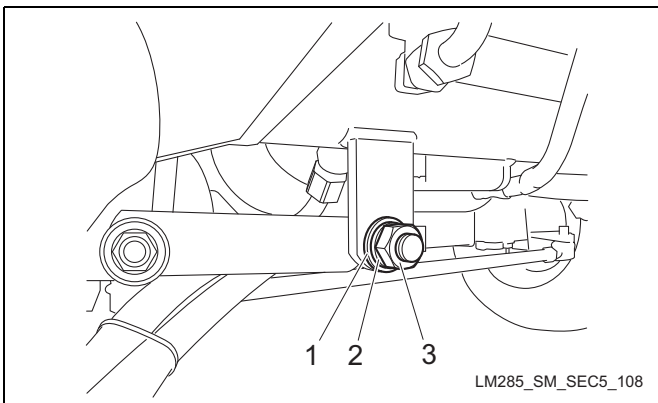

Figure: Hydraulic system-104-a

1	Washer
2	S washer
3	Nut

Removal of the selector valve on the left side of the machine

Caution

Exercise care in working due to the heavy selector valve.

1. Lower all the mower units with the raise/lower levers.
2. Drain the hydraulic oil. (Refer to “Change of hydraulic oil” (Page 5-42))
3. Remove the nut (2) of the unload lever (1) and draw out the shaft (4) for the stop ring (3) side and remove it.

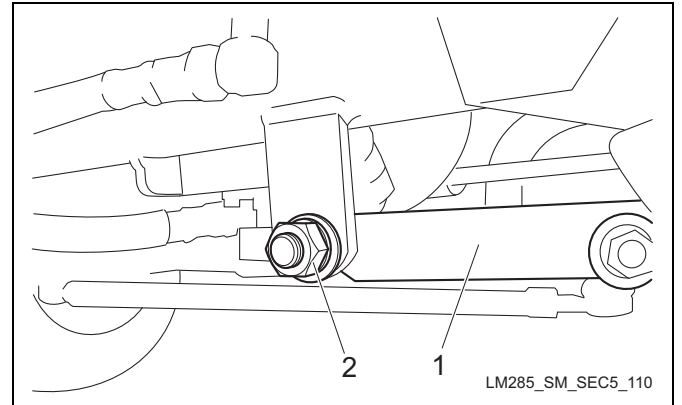

Figure: Hydraulic system-105-a

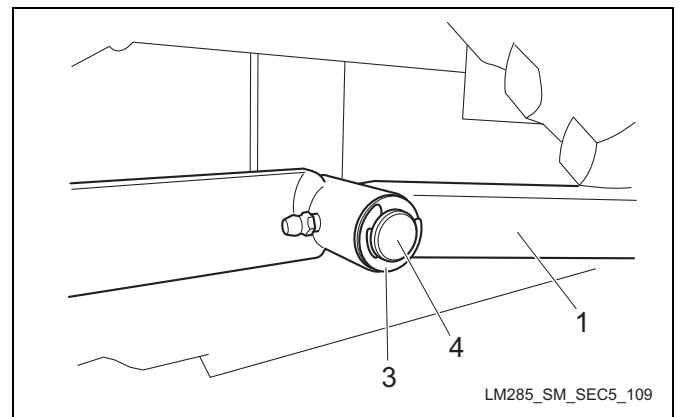

Figure: Hydraulic system-106-a

1	Unload lever
2	Nut
3	Stop ring
4	Shaft

4. Remove all the hydraulic hoses (2) attached to the selector valve (1).
5. Remove the bolt (3) fastening the selector valve (1) and remove the selector valve (1).

Hydraulic system

- Remove in order the adapter A (4), the adapter B (5), the connector (6), the elbow (7), the adapter C (8) and the T-shaped connector (9).

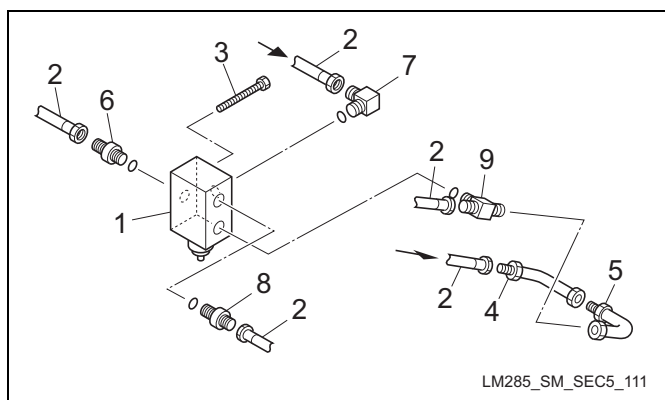

Figure: Hydraulic system-107-a

1	Selector valve
2	Hydraulic hose
3	Bolt
4	Adapter A
5	Adapter B
6	Connector
7	Elbow
8	Adapter C
9	T-shaped connector

Installation of the selector valve on the left side of the machine

⚠ Caution

Exercise care in working due to the heavy selector valve.

⚠ Caution

After fitting, check for hydraulic oil leakage in each section.

Refer to the tightening torques reference chart. We are not responsible for defects which occurred due to abnormal or overtorque tightening etc.

- Temporarily tighten the T-shaped connector (9) onto the selector valve (1) and tighten the adapter C (8).
- Temporarily tighten the elbow (7) and tighten the connector (6).
- Temporarily tighten in order the adapter B (5) and the adapter A (4).
- Install the selector valve (1) on the main body with the bolts (3).

- Taking care of each angle, tighten the adapter A (4), the adapter B (5), the elbow (7) and the T-shaped connector (9).

⚠ Caution

When installing the hydraulic hoses, exercise care in interference.

- Install the hydraulic hoses (2).

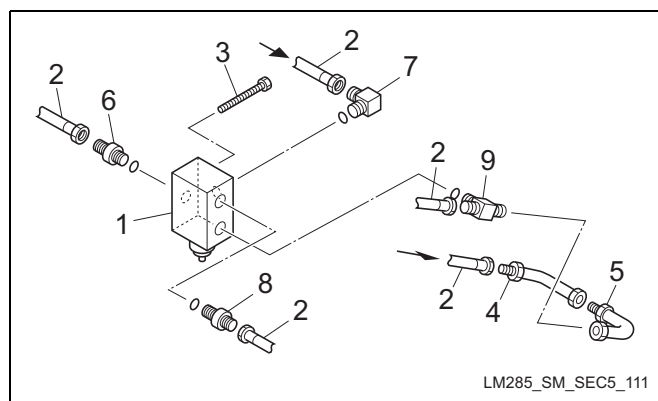

Figure: Hydraulic system-108-a

1	Selector valve
2	Hydraulic hose
3	Bolt
4	Adapter A
5	Adapter B
6	Connector
7	Elbow
8	Adapter C
9	T-shaped connector

- Apply grease on the shaft (1).
- Insert the bearing (3) in the unload lever (2) and attach the washer (4), the S washer (5) and the nut (6).
- Insert the shaft (1) in the unload lever (2) and install the washer (7) and stop it with the stop ring (8).

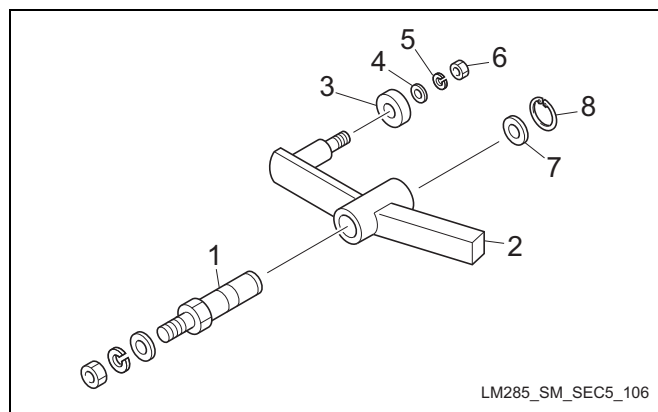

Figure: Hydraulic system-109-a

1	Shaft
2	Unload lever
3	Bearing
4	Washer
5	S washer
6	Nut
7	Washer
8	Stop ring

10. Insert the unload lever (2) in the frame section (1).

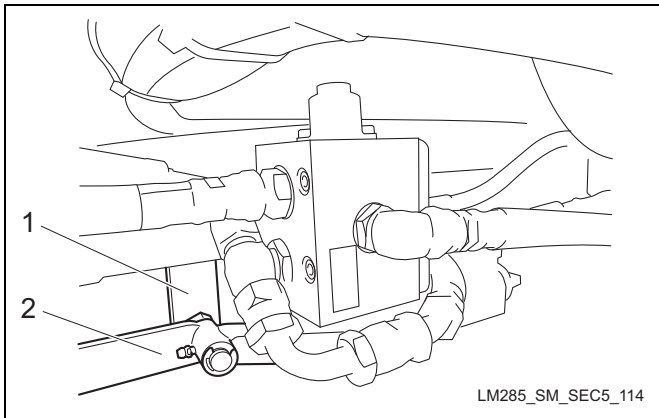

Figure: Hydraulic system-110-a

1	Frame section
2	Unload lever

11. Install the washer (1), the S washer (2) and the nut (3).

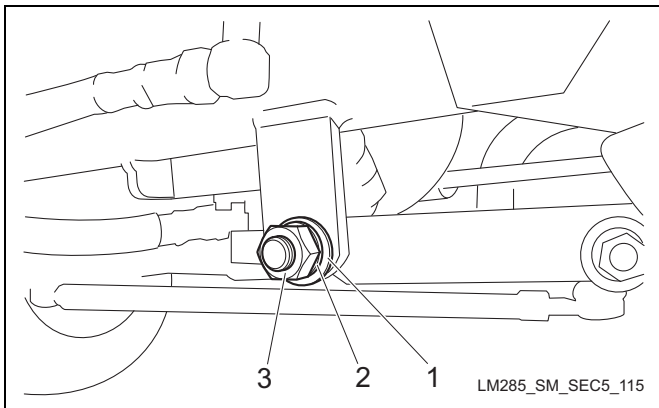

Figure: Hydraulic system-111-a

1	Washer
2	S washer
3	Nut

Steering cylinder

Removal of steering cylinder

Important

When removing the hydraulic hoses, confirm the positions of installation.

1. Remove the hydraulic hoses (1).
2. Remove the elbows (2).
3. Remove the nuts (3) and the spring washers (4) and then remove the steering cylinder (5).

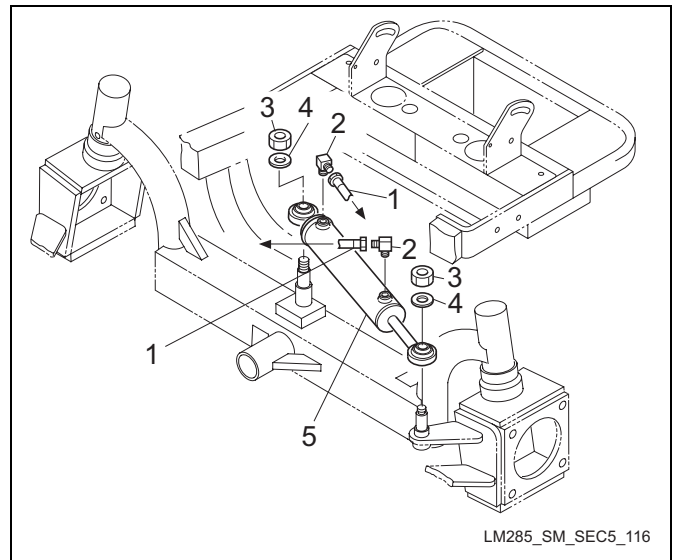

Figure: Hydraulic system-112-a

1	Hydraulic hose
2	Elbow
3	Nut
4	Spring washer
5	Steering cylinder

Installation of steering cylinder

Caution

After fitting, check for hydraulic oil leakage in each section.

Refer to the tightening torques reference chart. We are not responsible for defects which occurred due to abnormal or overtorque tightening etc.

For installation, reverse the removal procedures.

Hydraulic system

Oil cooler

Removal of oil cooler

1. Release the rubber catch and open the radiator cover.
2. Remove the battery. (Refer to “Battery” (Page 6-19))
3. Drain the hydraulic oil. (Refer to “Change of hydraulic oil” (Page 5-42))

Important

When removing the hydraulic hoses, confirm the positions of installation.

4. Remove the hydraulic hose (1).
5. Remove the bolts (3) and the S washers (4) on the right and left sides fastening the oil cooler (2) and remove the oil cooler (2).

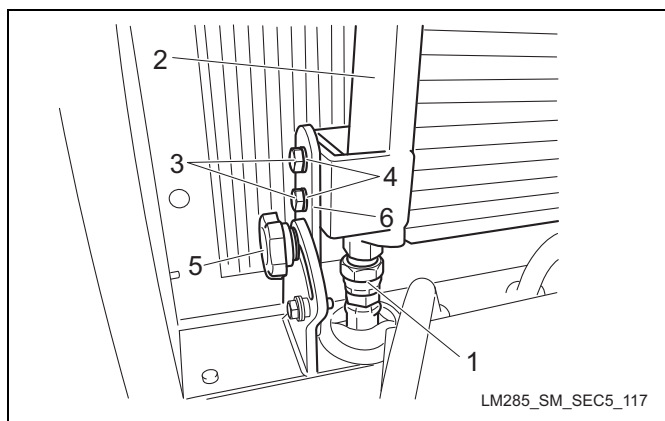

Figure: Hydraulic system-113-a

1	Hydraulic hose
2	Oil cooler
3	Bolt
4	S washer
5	Knob
6	Oil cooler fastening bracket

Installation of oil cooler

Caution

After fitting, check for hydraulic oil leakage in each section.

Refer to the tightening torques reference chart. We are not responsible for defects which occurred due to abnormal or overtorque tightening etc.

1. Loosen the knob (5).

2. Insert the oil cooler (2) between the right and left oil cooler fastening brackets (6) and temporarily tighten the bolts (3) and the S washers (4).
3. Install the hydraulic hose (1) to the oil cooler (2).
4. Surely tighten the bolts (3) and the S washers (4) to fasten the oil cooler (2) to the oil cooler fastening brackets (6).
5. Tighten the knob (5).

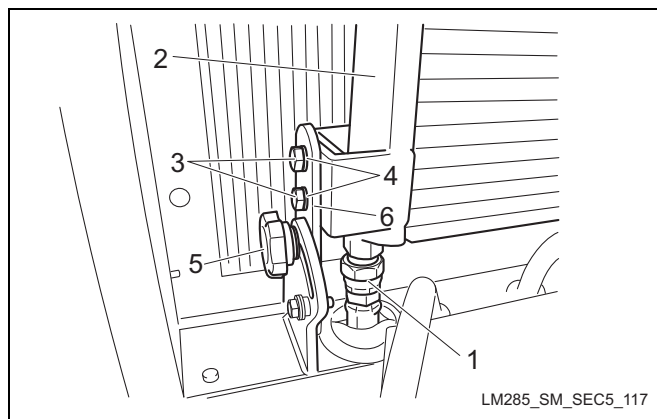

Figure: Hydraulic system-114-a

1	Hydraulic hose
2	Oil cooler
3	Bolt
4	S washer
5	Knob
6	Oil cooler fastening bracket

Manifold with emergency relief valve

Removal of front manifold with emergency relief valve

1. Remove the bolts (1), the S washers (2) and the washers (3) and remove the center cover rear (4).
2. Remove the bolts (5), the S washers (6) and the washers (7) and remove the center cover front (8).

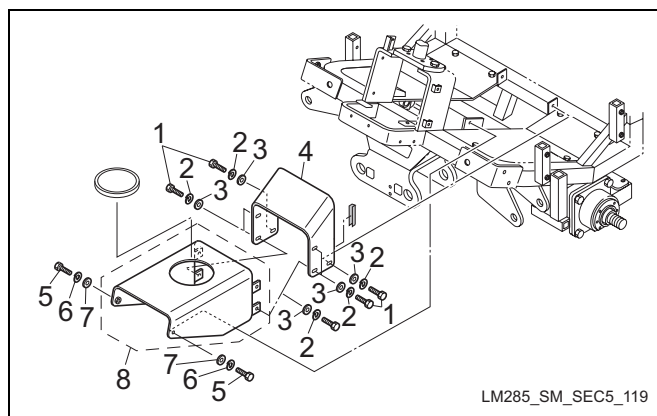

Figure: Hydraulic system-115-a

1	Bolt
2	S washer
3	Washer
4	Center cover rear
5	Bolt
6	S washer
7	Washer
8	Center cover front

3. Pull the slide lever (1) and slide the seat (2) to the forward end.

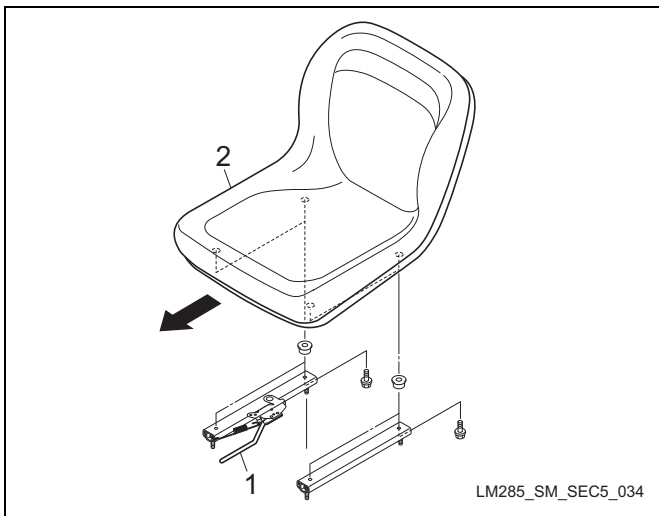

Figure: Hydraulic system-116-a

1	Slide lever
2	Seat

4. Remove the bolts (2), S washers (3) and washers (4) behind the seat, which fasten the cover under seat (1).

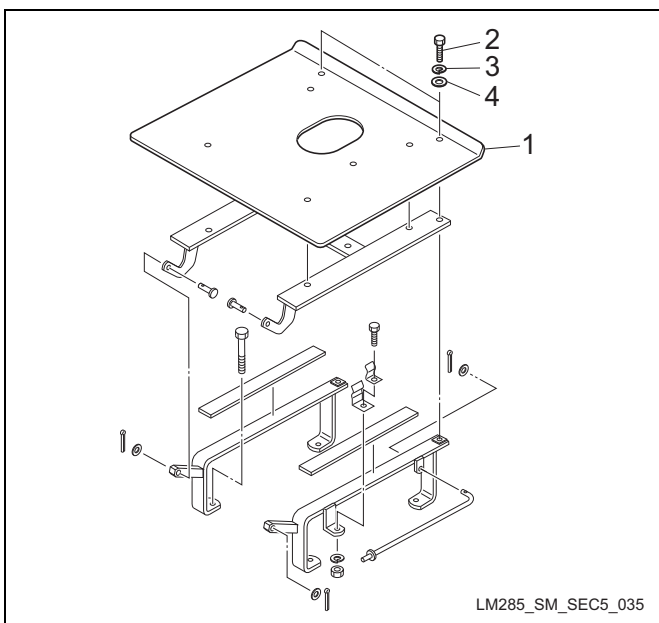

Figure: Hydraulic system-117-a

1	Cover under seat
2	Bolt
3	S washer
4	Washer

5. Lift up the seat (1).
6. Insert and fix the stand (2) to the seat mounting plate (3).

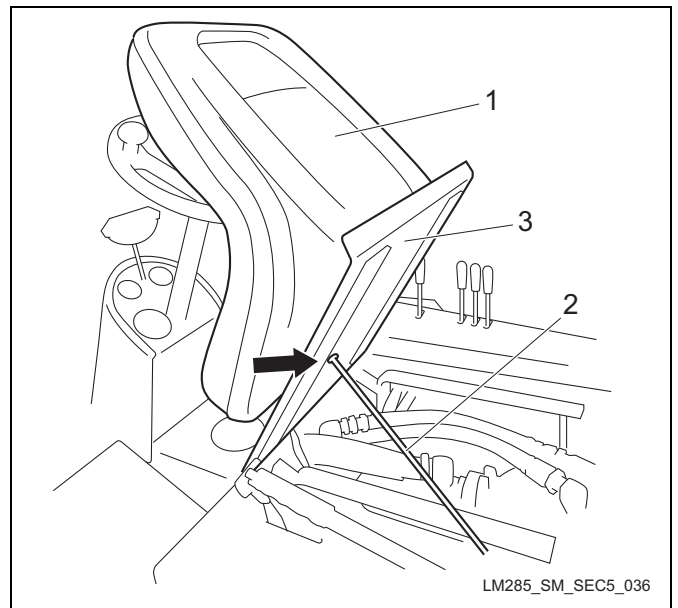

Figure: Hydraulic system-118-a

1	Seat
2	Stand
3	Seat mounting plate

7. Loosen the band (3) of the hydraulic hose (2) attached to the piston pump (1) and remove the hydraulic hose (2).

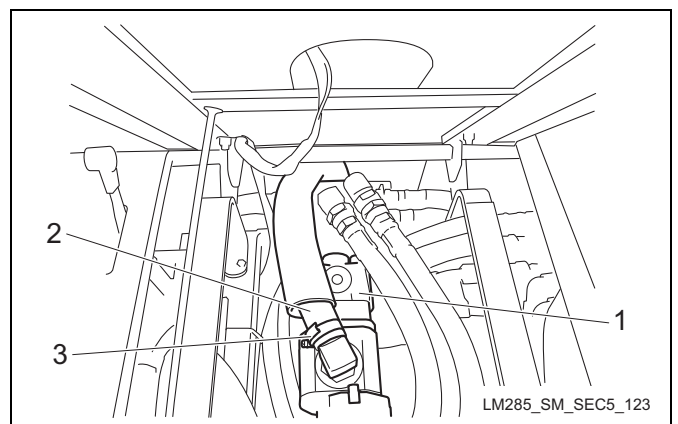

Figure: Hydraulic system-119-a

1	Piston pump
2	Hydraulic hose
3	Band

Hydraulic system

Important

When removing the hydraulic hoses, confirm the positions of installation.

8. Remove the hydraulic hoses (1).
9. Remove the bolts (2) and the S washers (3) and then remove the manifold with emergency relief valve (4).
10. Remove in order the adapter A (5), the elbow A (6), the elbow B (7) and the adapter B (8) from the removed manifold with emergency relief valve (4).

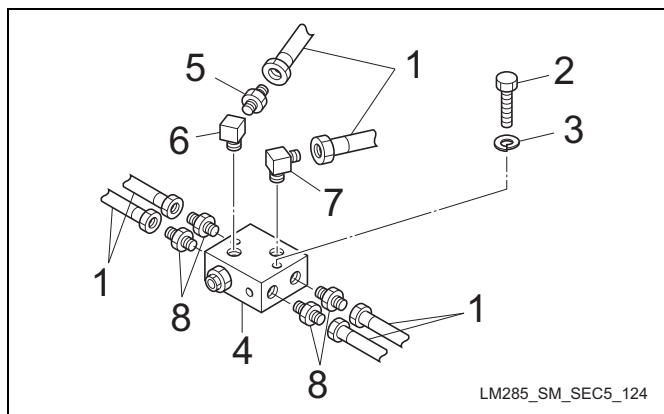

Figure: Hydraulic system-120-a

1	Hydraulic hose
2	Bolt
3	S washer
4	Manifold with emergency relief valve
5	Adapter A
6	Elbow A
7	Elbow B
8	Adapter B

Installation of front manifold with emergency relief valve

Caution

After fitting, check for hydraulic oil leakage in each section.

Refer to the tightening torques reference chart. We are not responsible for defects which occurred due to abnormal or overtorque tightening etc.

For installation, reverse the removal procedures.

Removal of rear manifold with emergency relief valve

1. Remove the hydraulic hoses (1).

2. Remove the bolts (2) and the S washers (3) and remove the manifold with emergency relief valve (4).
3. Remove in order the adapter (5), the elbow A (6), the elbow B (7) and the elbow C (8) from the removed manifold with emergency relief valve (4).

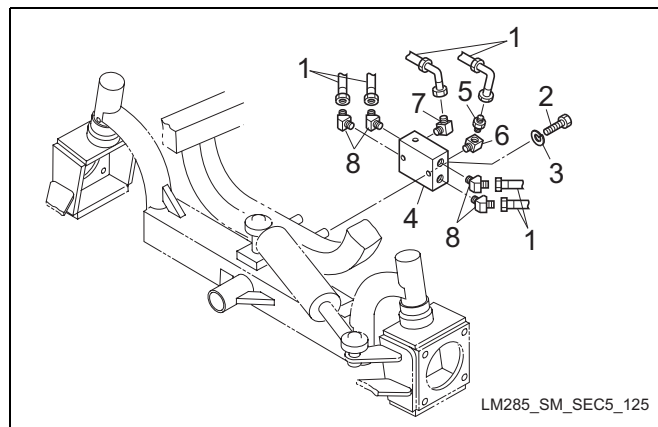

Figure: Hydraulic system-121-a

1	Hydraulic hose
2	Bolt
3	S washer
4	Manifold with emergency relief valve
5	Adapter
6	Elbow A
7	Elbow B
8	Elbow C

Installation of rear manifold with emergency relief valve

Caution

After fitting, check for hydraulic oil leakage in each section.

Refer to the tightening torques reference chart. We are not responsible for defects which occurred due to abnormal or overtorque tightening etc.

For installation, reverse the removal procedures.

Wheel motor

Removal of front wheel motor

Caution

Work in a twosome due to the heavy wheel motor.

1. Remove the front wheel. (Refer to "Removal of front wheel" (Page 7-6))

- Remove the brake. (Refer to “Removal of brake drum” (Page 7-7))
- Remove the key (1) of the wheel motor.

Important

When removing the hydraulic hoses, confirm the positions of installation.

- Remove the hydraulic hoses (3) attached to the wheel motor (2).
- Remove the bolts (5) and the S washers (6) fastening the hydraulic motor mounting bracket (4) and remove the hydraulic motor mounting bracket (4).
- Remove the wheel motor (2).

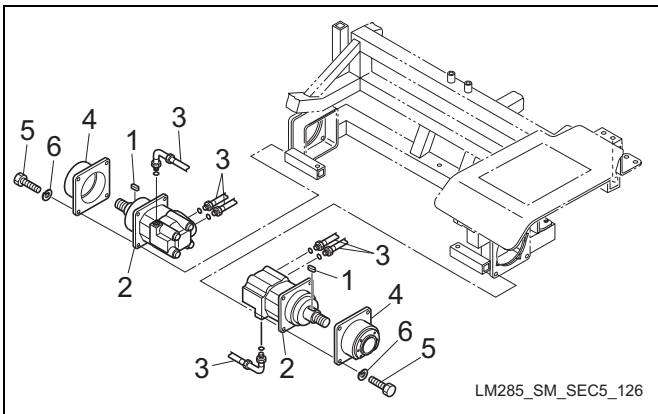

Figure: Hydraulic system-122-a

1	Key
2	Wheel motor
3	Hydraulic hose
4	Hydraulic motor mounting bracket
5	Bolt
6	S washer

Installation of front wheel motor

Caution

After fitting, check for hydraulic oil leakage in each section.

Refer to the tightening torques reference chart. We are not responsible for defects which occurred due to abnormal or overtorque tightening etc.

For installation, reverse the removal procedures.

Removal of rear wheel motor

Caution

Work in a twosome due to the heavy wheel motor.

- Remove the rear wheel. (Refer to “Removal of rear wheel” (Page 7-7))
- Remove the split pin (2) attached to the slotted high nut (1).

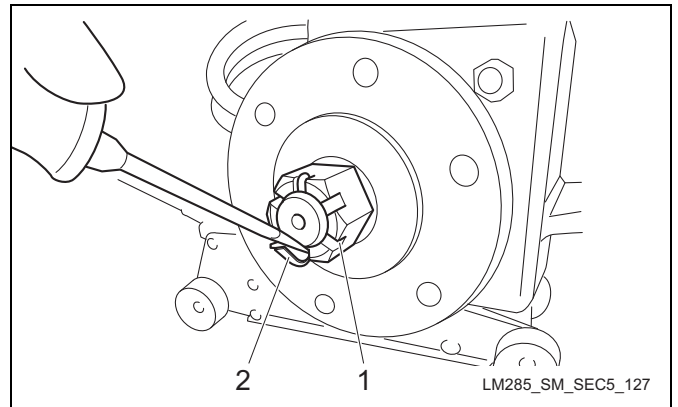

Figure: Hydraulic system-123-a

1	Slotted high nut
2	Split pin

- Loosen the slotted high nut (1) to the extent of play on the washer (4).
- Hook the rear wheel mounting base (2) with a gear puller and separate the rear wheel mounting base (2) from the wheel motor shaft.
- Remove the slotted high nut (1), the washer (4) and the rear wheel mounting base (2).

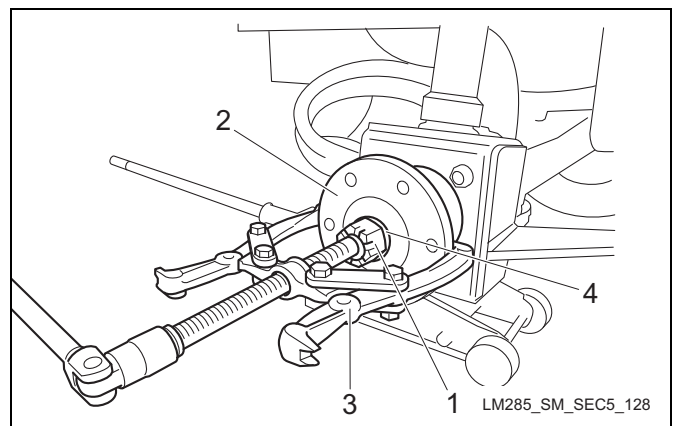

Figure: Hydraulic system-124-a

1	Slotted high nut
2	Rear wheel mounting base
3	Gear puller
4	Washer

Hydraulic system

- Remove the key (2) of the wheel motor.

Important

When removing the hydraulic hoses, confirm the positions of installation.

- Remove the hydraulic hoses (3) attached to the wheel motor (1).
- Remove the bolts (5), the S washers (6) and the nuts (7) fastening the wheel motor (1) to the king pin (4).
- Remove the wheel motor (1).

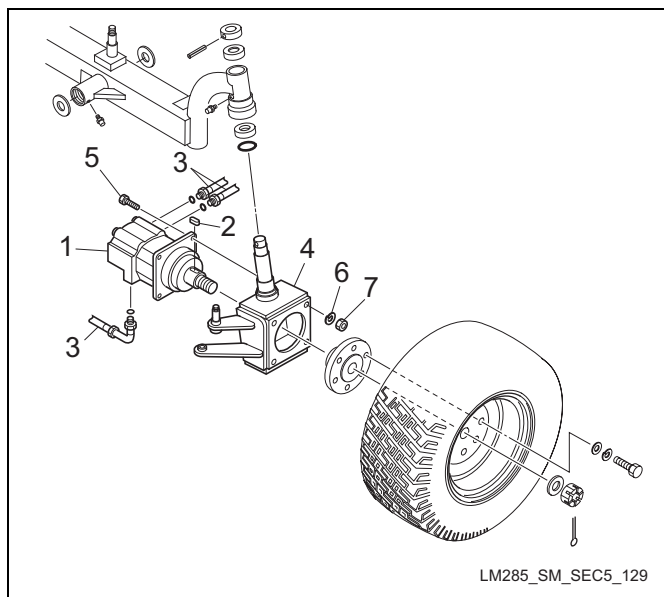

Figure: Hydraulic system-125-a

1	Wheel motor
2	Key
3	Hydraulic hose
4	King pin
5	Bolt
6	S washer
7	Nut

Installation of rear wheel motor

Caution

After fitting, check for hydraulic oil leakage in each section.

Refer to the tightening torques reference chart. We are not responsible for defects which occurred due to abnormal or overtorque tightening etc.

For installation, reverse the removal procedures.

Manifold with solenoid valve

Removal of manifold with solenoid valve

- Remove the battery cable of the minus side. (Refer to "Battery" (Page 6-19))
- Remove the bolts (1), the S washer (2) and the washer (3) and then remove the center cover rear (4).
- Remove the bolts (5), the S washers (6) and the washer (7) and then remove the center cover front (8).

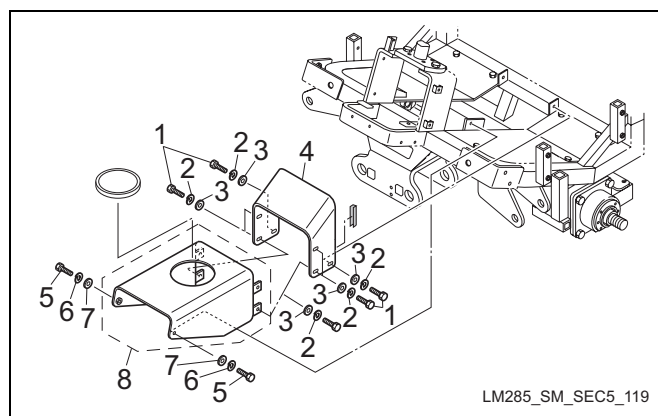

Figure: Hydraulic system-126-a

1	Bolt
2	S washer
3	Washer
4	Center cover rear
5	Bolt
6	S washer
7	Washer
8	Center cover front

- Cut off the band (1) and pull out the solenoid valve connector (2).

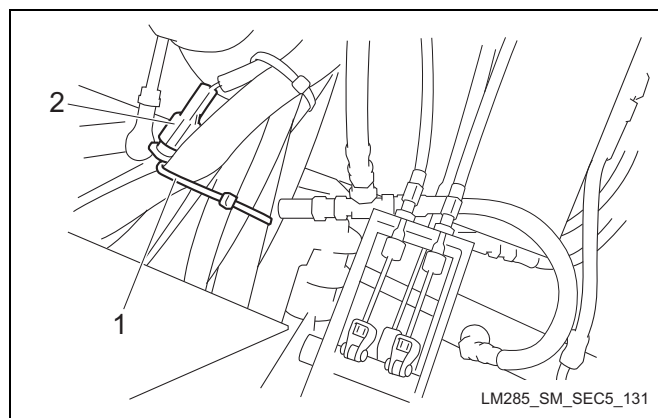

Figure: Hydraulic system-127-a

1	Band
2	Solenoid valve connector

- Remove in order the hydraulic hose A (1), the adapter A (2), the adapter B (3), the adapter C (4), the adapter D (5) and the hydraulic hose B (6).

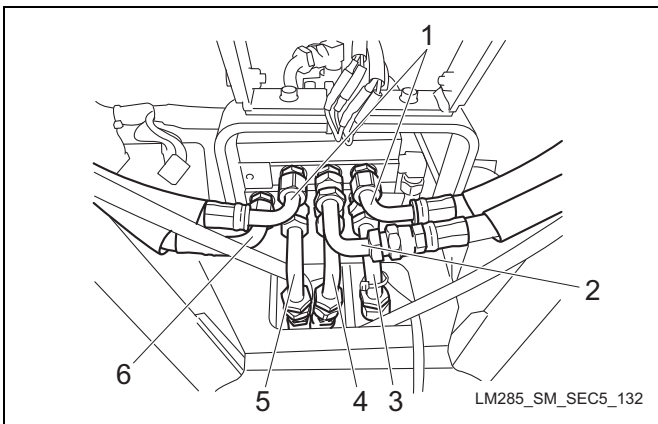

Figure: Hydraulic system-128-a

1	Hydraulic hose A
2	Adapter A
3	Adapter B
4	Adapter C
5	Adapter D
6	Hydraulic hose B

- Loosen the bolts (1), the S washers (2) and the washers (3) and pull the manifold with solenoid valve (4) a little to the direction of the seat side.

Important

When removing the hydraulic hoses, confirm the positions of installation.

- Remove the hydraulic hoses (5) and remove the manifold with solenoid valve (4) from the seat side.
- Remove the adapter (6) and the elbow (7).

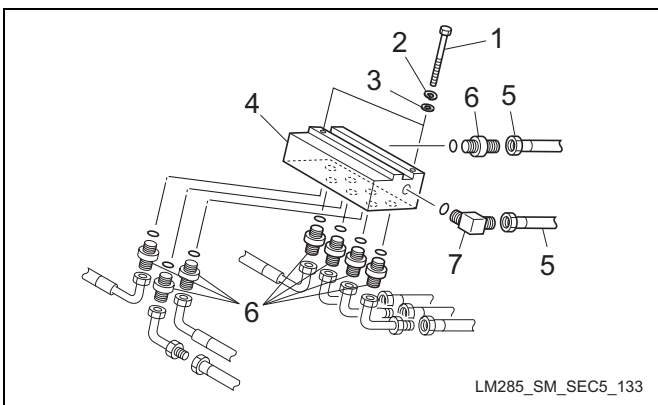

Figure: Hydraulic system-129-a

1	Bolt
2	S washer
3	Washer
4	Manifold with solenoid valve
5	Hydraulic hose
6	Adapter
7	Elbow

Installation of manifold with solenoid valve

Caution

After fitting, check for hydraulic oil leakage in each section.

Refer to the tightening torques reference chart. We are not responsible for defects which occurred due to abnormal or overtorque tightening etc.

For installation, reverse the removal procedures.

Orbitrol

Removal of Orbitrol

- Remove the front cover. (Refer to “Removal of front cover” (Page 7-17))
- Remove the gauge panel. (Refer to “Removal of gauge panel” (Page 7-19))
- Remove the steering. (Refer to “Removal of steering” (Page 7-8))

Important

When removing the hydraulic hoses, confirm the positions of installation.

- Remove the hydraulic hoses (1).
- Remove in order the adapter A (2), the adapter B (3), the elbow A (4) and the elbow B (5).

Caution

Orbitrol has a spline shaft. Exercise care to avoid damaging it.

- Remove the steering column. (Refer to “Removal of steering column” (Page 7-8))

Hydraulic system

7. Remove Orbitrol (6).

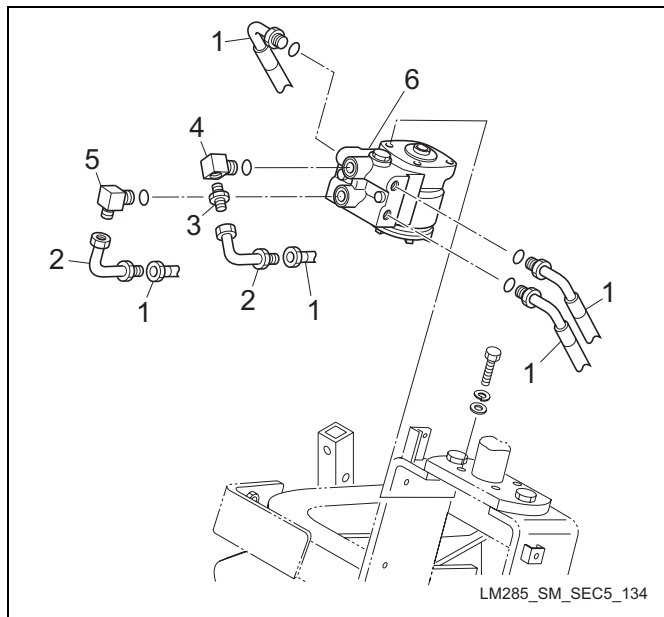

Figure: Hydraulic system-130-a

1	Hydraulic hose
2	Adapter A
3	Adapter B
4	Elbow A
5	Elbow B
6	Orbitrol

Installation of Orbitrol

Caution

After fitting, check for hydraulic oil leakage in each section.

Refer to the tightening torques reference chart. We are not responsible for defects which occurred due to abnormal or overtorque tightening etc.

For installation, reverse the removal procedures.

Hydraulic tank

Removal of hydraulic tank

Caution

Exercise care in working due to the heavy hydraulic tank.

1. Lower all the mower units with the raise/lower levers.
2. Drain the hydraulic oil. (Refer to “Change of hydraulic oil” (Page 5-42))

3. Remove the steering. (Refer to “Removal of steering” (Page 7-8))
4. Remove Orbitrol. (Refer to “Removal of Orbitrol” (Page 5-63))
5. Remove the lever damper. (Refer to “Removal of lever damper” (Page 7-22))
6. Remove the step left. (Refer to “Removal of step left” (Page 7-20))
7. Remove the nut (1).
8. Remove the bolts (2) and remove the neutral bracket (3).

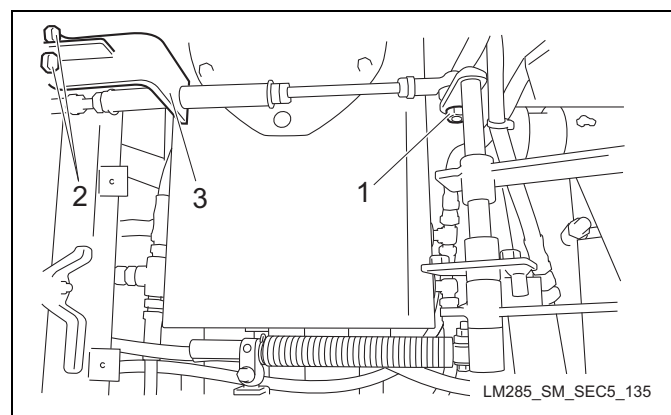

Figure: Hydraulic system-131-a

1	Nut
2	Bolt
3	Neutral bracket

Important

When removing the rods, confirm the positions and directions of installation.

9. Remove the nuts (1) and the S washers (2) and then remove the rod (3).

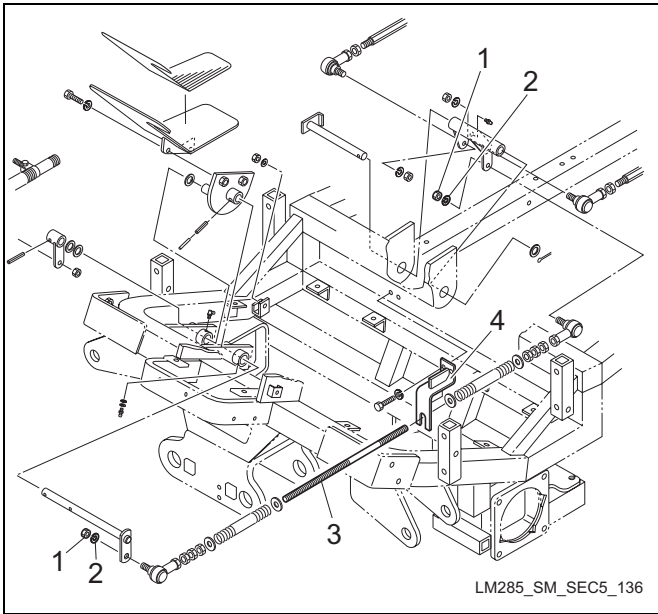

Figure: Hydraulic system-132-a

1	Nut
2	S washer
3	Rod
4	Neutral bracket

- Remove the manifold with solenoid valve. (Refer to "Removal of manifold with solenoid valve" (Page 5-62))
- Remove the split pins (1) and the washers (2) and pull out the pin (3).

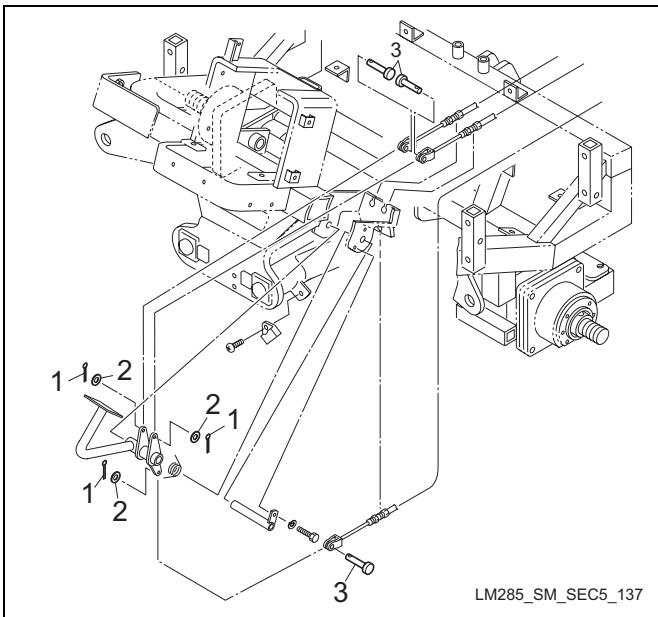

Figure: Hydraulic system-133-a

1	Split pin
2	Washer
3	Pin

- Loosen the lock nuts (1) and the adjuster bolts (2) and remove the brake wires (3).

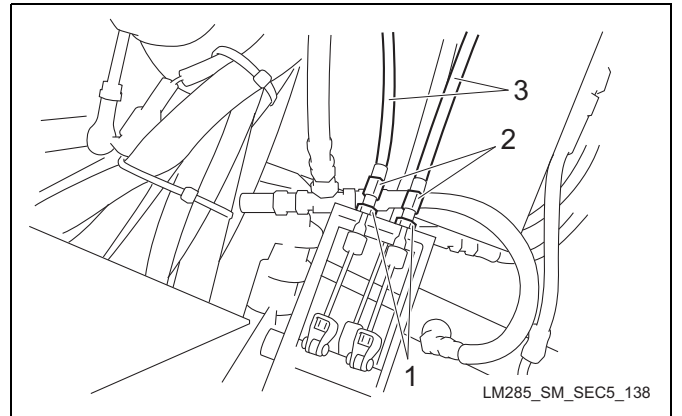

Figure: Hydraulic system-134-a

1	Lock nut
2	Adjuster bolt
3	Brake wire

Important

When removing the hydraulic hoses, confirm the positions of installation.

- Remove all the hydraulic hoses (1).
- Loosen the band (2) and remove the suction hose (3).

Important

When removing the elbows and the adapters, confirm the positions and directions of installation.

- Remove the elbows (4) and the adapters (5).

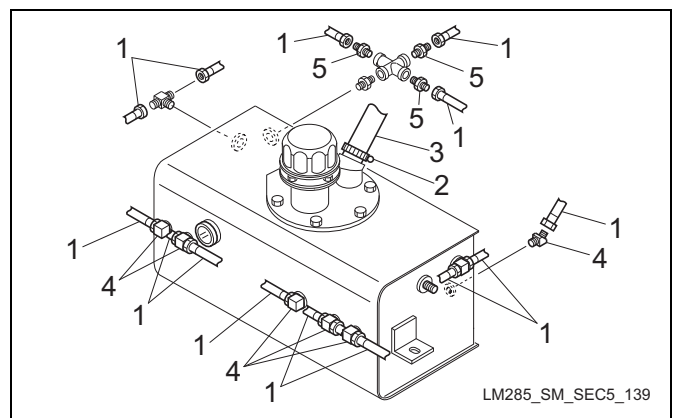

Figure: Hydraulic system-135-a

Hydraulic system

1	Hydraulic hose
2	Band
3	Suction hose
4	Elbow
5	Adapter

16. Remove the bolts (1), the washers (2), the nuts (11) and the S washers (12) and then remove the hydraulic tank (3).
17. Remove the oil level plug (4).
18. Remove the plug (5).
19. Remove the bolts (6), the S washers (7) and the washers (8).

Important

When removing the hydraulic suction port, confirm the position and direction of installation.

20. Remove the hydraulic suction port (9) and the packing (10).

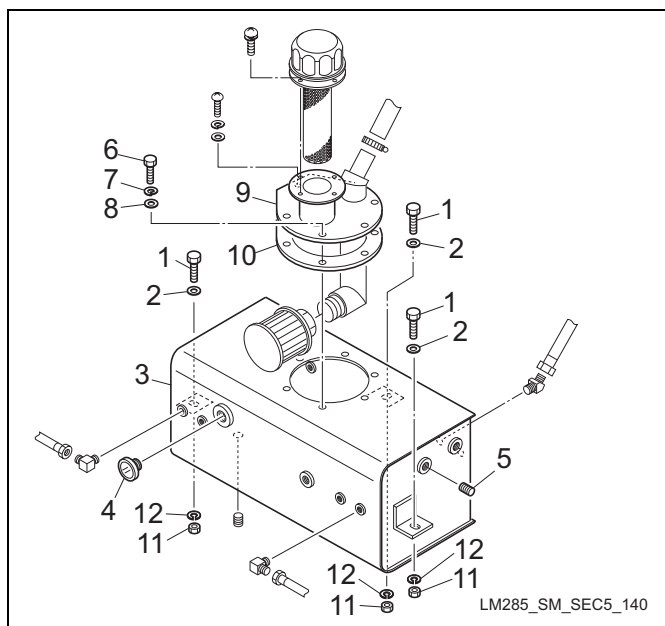

Figure: Hydraulic system-136-a

1	Bolt
2	Washer
3	Hydraulic tank
4	Oil level plug
5	Plug
6	Bolt
7	S washer
8	Washer
9	Hydraulic suction port
10	Packing
11	Nut
12	S washer

Installation of hydraulic tank

Caution

Exercise care in the directions of the elbows and the adapters.

Caution

After fitting, check for hydraulic oil leakage in each section.

Refer to the tightening torques reference chart. We are not responsible for defects which occurred due to abnormal or overtorque tightening etc.

For installation, reverse the removal procedures.

Maintenance	6-2
Specifications	6-3
Adjusted value	6-3
Layout of electrical components	6-4
Special tools	6-6
Measurement method	6-6
Battery	6-6
Interlock system	6-7
Adjustment	6-8
Parking brake switch	6-8
Reel rotation switch	6-9
Neutral switch	6-10
Maintenance switch	6-10
Proximity switch	6-11
Electrical components	6-11
Safety switch	6-11
Seat switch	6-12
Parking brake switch	6-12
Reel rotation switch	6-12
Neutral switch	6-13
Maintenance switch	6-13
Proximity switch	6-13
Solenoid valve	6-14
Key switch	6-14
Pilot lamp	6-15
Fuel gauge	6-16
Water temperature gauge	6-16
Tachometer, Hour meter	6-16
Starter relay	6-16
Glow lamp timer	6-17
Fusible link	6-17
Fuse box	6-17
Fuel pump	6-18
Fuel unit	6-18
Rotation sensor (Electromagnetic pick up)	6-18
Buzzer	6-19
Light switch	6-19
General inspection and repair	6-19
Battery	6-19

Electrical system

Maintenance

This chapter briefly describes how to inspect and maintain the electrical systems of “LM285.” For daily inspection, maintenance, and handling of this machine, refer to the owner’s manual and parts catalogue for “LM285.”

For details on handling the battery, refer to the instruction manual provided with it.

Danger

When performing inspection and maintenance, follow these safety instructions.

1. Before performing adjustments or maintenance, etc., park the machine on a level area. Set the parking brake, stop the engine and remove the key. Before performing adjustments or maintenance, etc., ensure that each component of the machine has completely stopped.
2. Keep your hands and feet away from moving parts. Avoid performing work with the engine running. Keep other people away from the machine during work.
3. If necessary, use appropriate chain blocks, hoists, or a jack. If the machine is lifted up, ensure that it is supported by jack stands or appropriate blocks.
4. When replacing parts or installing accessory parts, use genuine BARONESS parts.
5. Never start the engine in a closed room. Doing so could cause carbon monoxide poisoning.
6. Never touch the exhaust system while the machine is operating or immediately after the engine has stopped. Doing so could cause burns resulting from the extreme heat.
7. Never use open flames near the battery. Hydrogen gas may be generated from the battery. Improper handling of the battery could cause an explosion.
8. The electrolyte contained in the battery is sulfuric acid. Contact of the electrolyte (sulfuric acid) with the skin could cause blindness or burns. Contact of the electrolyte with the machine etc. could cause damage to the machine.

Specifications

Adjusted value

Parking brake switch	Forward tilting from vertical line by 10 degrees	Positions of the switch lever and the switch main unit
	Parking brake lever 2 to 3 notches	Conduction of the first stage
	Parking brake lever more than 4 notches	Conduction of the second stage
Traveling neutral switch	Push-in amount 2.5mm (0.10 in)	Traveling neutral state
Maintenance switch	Push-in amount 4 to 5mm (0.16 to 0.20 in)	Backlapping state
Mower proximity switch	Within 5mm (0.20 in)	Distance between the switch and the magnet for detection
	From the ground to the outer end of the cutting edge of #3 mower unit 400mm (15.75 in)	Position of the magnet for detection (#3 mower arm fulcrum)

Adjustment of Safety Switch

Refer to “Adjustment” (Page 6-8) for adjustment method.

Electrical system

Layout of electrical components

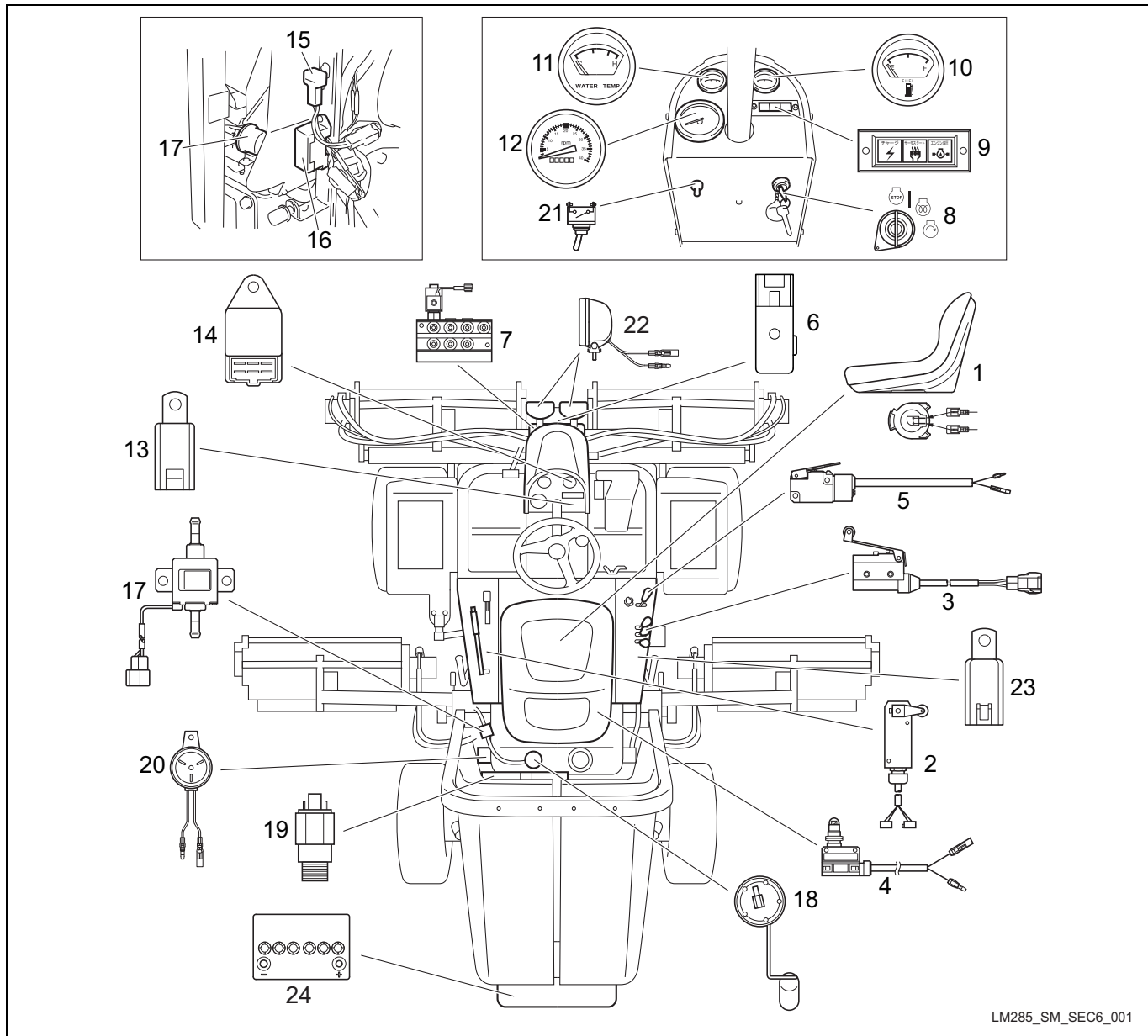

LM285_SM_SEC6_001

Figure: Electrical system-1-a

1	Seat switch
2	Parking brake switch
3	Reel rotation switch
4	Neutral switch
5	Maintenance switch
6	Proximity switch
7	Solenoid valve
8	Key switch
9	Pilot lamp
10	Fuel gauge
11	Water temperature gauge
12	Tachometer, Hour meter

13	Starter relay
14	Glow lamp timer
15	Fusible link
16	Fuse box
17	Fuel pump
18	Fuel unit
19	Rotation sensor (Electromagnetic pick up)
20	Buzzer
21	Light switch
22	Lights
23	Relay
24	Battery

1. Seat switch [NO type (ON when pressed)]

The seat switch is one of the safety switches of the interlock system and is located in the seat cushion.
2. Parking brake switch [2NC, 2NO type]

The parking brake switch is one of the safety switches of the interlock system and is located in the parking brake lever fulcrum.
3. Reel rotation switch

The reel rotation switch is one of the safety switches of the interlock system and is located in the reel rotation lever under the right side front cover. The front side relates to the engine stop solenoid and the rear side relates to the starter motor.
4. Neutral switch

The neutral switch relates to the neutral lever attached to the shift lever of the piston pump (pump for traveling) and detects neutral state of the shift lever. It is one of the safety switches of the interlock system and is located near the neutral lever in the frame.
5. Maintenance switch

The maintenance switch relates to the reel negative rotation stopper. When the stopper is switched to “BACKLAPPING” side, the reel cutter can reverse even if the operator leaves the seat. It is located on the reverse side of the right side front cover.
6. Proximity switch

The proximity switch detects moving away of the plastic magnet for detection attached to #3 mower arm fulcrum. It is one of the safety switches of the interlock system and is located near #3 mower arm fulcrum in the frame.
7. Solenoid valve

The solenoid valve relates to the proximity switch in #3 mower arm and switches the hydraulic pathways for rotation/stop of all the reels. It is attached to the manifold under the front cover.
8. Key switch

The key switch is used to start, run and stop the engine and is located in the lower right of the operation panel.
9. Pilot lamp

The pilot lamp indicates charge, glow and the hydraulic state on the engine and is located in the upper right of the operation panel.
10. Fuel gauge

The fuel gauge indicates fuel quantity in the fuel tank and is located in the upper right of the operation panel.
11. Water temperature gauge

The water temperature gauge indicates the temperature of cooling water for the engine and is located in the upper left of the operation panel.
12. Tachometer, Hour meter

The tachometer indicates the rotation frequency of the engine during the engine running.
The hour meter indicates the accumulated operation time of the engine and is located in the upper left of the operation panel.
Conduct periodic inspections and maintenance service according to the number of hours.
13. Starter relay

The starter relay is one of the relays of the interlock system and located in the upper right side under the front cover. The starter motor can be started only when the safety switches and the alternator work properly.
14. Glow lamp timer

The glow lamp timer controls lighting of the thermo-start lamp of the pilot lamp and is located in the right front side under the front cover. Holding “Glow” of the key switch makes the thermo-start lamp light up for 5 seconds.
15. Fusible link

The fusible link works as the main fuse of the whole circuit and the fuse of the charge circuit. It is located in the left front side under the left bonnet and has a cartridge fuse for exclusive use (50A).
16. Fuse box

It is connected to each electrical component through fuses from the key switch. The standard of the fuse for use is mini fuse for a car. It is located in the left front side under the left bonnet.
17. Fuel pump

The fuel pump transports the fuel which has passed through the fuel filter to the injection pump and is located on the frame in the left side of the fuel tank.
18. Fuel unit

The fuel unit is connected to the fuel gauge and measures the fuel level by the float position. It is located on the upper side of the fuel tank.
19. Rotation sensor (Electromagnetic pick up)

The electromagnetic pickup detects the rotation of the flywheel gear in the engine as a signal and lets the tachometer indicate the rotation frequency. It is located near the flywheel gear of the engine.
20. Buzzer

Electrical system

The buzzer is connected to the water temperature switch of the thermostat case of the engine and rings when the temperature of the cooling water increases up to 105 degrees C. It is located in the wind shielding plate at the back of the fuel tank.

21. Light switch

The light switch is used to light up/down the headlight and located in the lower left of the operation panel.

22. Lights (12V55W)

The lights can be turned on and off by operating the light switch and is located in the front side of the main body.

They are daytime lights. Do not operate the machine during nighttime or when visibility is poor.

23. Relay

The relay is located under the right side front cover. The upper side relates to the seat switch and the lower side the proximity switch (reel rotation).

24. Battery

The battery supplies the power to the starter for starting the engine and to the electrical components. It is located under the radiator cover.

following formula to obtain a temperature-corrected specific gravity.

$$S_{20} = S_t + 0.0007(t - 20)$$

LM285_SM_SEC6_002

Figure: Electrical system-2-a

1	Specific gravity at 20°C
2	Measured specific gravity
3	Electrolyte temperature

Temperature-corrected specific gravity and remaining battery capacity		
Specific gravity (20°C)	Amount of electricity discharged (%)	Remaining battery capacity (%)
1.28	0	100
1.24	25	75
1.20	50	50
1.16	75	25
1.12	100	0

Special tools

No use of special tools is required.

Measurement method

Battery

Battery specific gravity measurement

Because the specific gravity of the electrolyte decreases almost in proportion to the amount of electricity discharged from the battery, it is possible to ascertain the remaining battery capacity by measuring the specific gravity of the electrolyte using a hydrometer.

The specific gravity measured by the hydrometer needs to be temperature-corrected. The standard temperature for the specific gravity of battery electrolyte is 20°C, and the specific gravity increases or decreases by 0.0007 as the temperature increases or decreases by 1°C. Use the

■ 12-V battery specific gravity measurement

1. After charging the battery, measure the specific gravity of all the cells.
2. If the specific gravity is 1.225 or less, or the difference in specific gravity between cells is 0.05 or more, replace the battery.

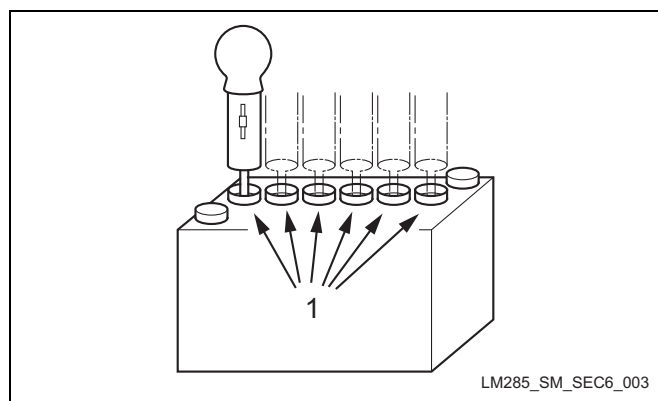

Figure: Electrical system-3-a

1	Cell
---	------

Battery charging

Follow this procedure to fully charge the battery.

Warning

When charging the battery, do not use a current in excess of one tenth of the rated current. With regard to the maximum recommended charging current, follow the battery manufacturer's instructions.

Caution

If the battery gets extremely hot or releases a significant amount of gas during charging, unplug the battery charger at regular intervals.

1. Use a taper battery charger, which automatically reduces the charging rate during charging.
2. After charging is completed, fill the battery cells with distilled water (if the battery is in use).
3. After charging is completed, measure and record the specific gravity of each cell using a battery hydrometer. (See Figure: Electrical system-3-a)
4. If the measured specific gravity is 1.225 or less, or the difference between the cells is equal to or exceeds 0.05, replace the battery with a new one.

Interlock system

The interlock system is a complex safety device that is controlled by switches and sensors to prevent injuries and accidents due to the operator's carelessness

The solenoid for fuel stop relates to the parking brake switch, the reel rotation switch (and the maintenance switch) and the neutral switch with the relay action by the seat switch.

The solenoid for reel rotation stop relates to the relay action by the proximity switch.

Interlock system condition chart

	Action	Engine status			Conditions				
					Seat	Parking brake	Reel rotation lever	Traveling pedal	Maintenance switch
		Start	Run	Stop	Occupied	Pull-up	Neutral	Neutral	ON
1	Engine start	○			○	○	○	○	—
2	Traveling		○		○	—	—	—	—
3	Operating		○		○	—	—	—	—
4	Parking		○		—	○	○	○	—
5	Maintenance		○		—	○	(Lapping side)	○	○

1. The engine starts only when the seat is occupied, the parking brake is set (the lever is pulled up) and the reel rotation lever in the neutral position.
However, in case that the traveling pedal is not in the neutral position, the starter motor can revolve but the engine can not be started.
2. For traveling (normal move), sit on the seat, release the parking brake (lower the lever) and depress the traveling pedal to the forward side or reverse side from the neutral position.
However, the engine will stop under the following conditions.
 - The operator depresses the traveling pedal while the parking brake lever is pulled up.
 - The operator releases the parking brake (lower the parking brake lever) while the seat is not occupied.
 - The operator moves the reel rotation lever (positive rotation side) while the parking brake lever is pulled up.
3. For operating (positive reel rotation), sit on the seat. If not, the engine will stop.
4. Even when the operator leaves the seat, the engine will not stop under the condition of setting the parking brake (pulling up the lever) and neutral position of the reel rotation lever and the traveling pedal.
However, the engine will stop when even one of the above conditions is not met.
5. For maintenance (Lapping), turn the stopper of the reel rotation lever to BACKLAPPING side.

Electrical system

However, the engine will stop when even one of the conditions of the parking brake, the traveling pedal and and/or the maintenance switch is not met.

How to check the operation of the interlock system

1. In the status of the engine start, check if the engine will stop when even one of the operation conditions on the seat, the parking brake, the reel rotation lever and the traveling pedal is not met.

Important

To check the operation, turn the reel rotation stop lever in the reel motor to STOP.

2. In the status of the engine Run under the maintenance conditions, leave the seat, move the stopper of the reel rotation lever to MOWING side (up to its contact with the reel rotation lever in the state of REVERSE) and check if the engine will stop.

Adjustment

Parking brake switch

Release the parking brake (1) (or lower the lever), loosen the hexagon socket head bolt (3) and adjust the limit switch lever (2) so that the limit switch lever (2) can have slightly touch the parking brake.

Status of the parking brake release (the lever lowered)

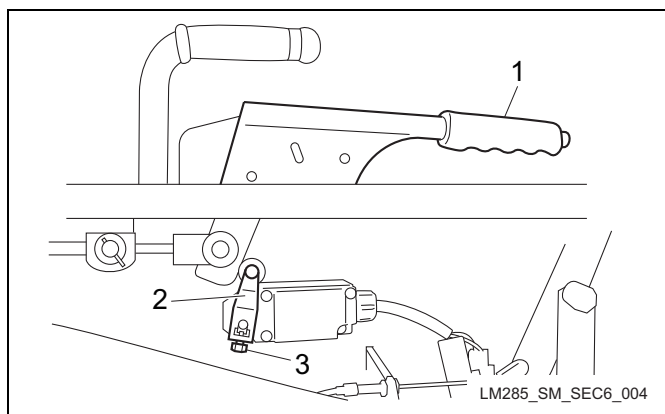

Figure: Electrical system-4-a

1	Parking brake lever
2	Limit switch lever
3	Hexagon socket head bolt

Status of the parking brake application (the lever pulled-up)

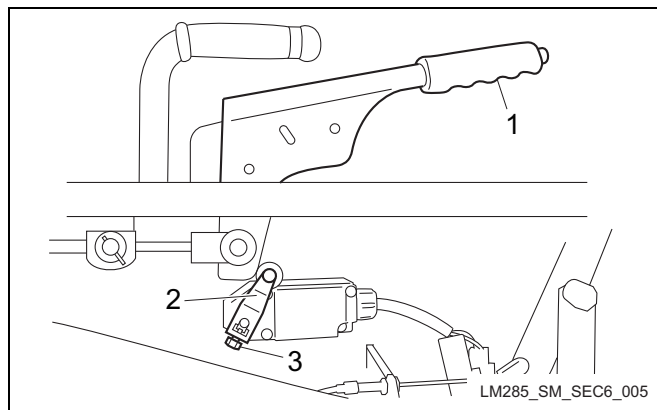

Figure: Electrical system-5-a

1	Parking brake lever
2	Limit switch lever
3	Hexagon socket head bolt

To check the operation of the parking brake switch, check if the engine can start under the condition of sitting on the seat, neutral position of the traveling pedal and application of the parking brake (or pulled-up lever).

Check if the engine will stop when the parking brake is released (or the lever lowered) and the operator leaves the seat. (Refer to "Interlock system" (Page 6-7))

Angle adjustment of the limit switch lever

1. Loosen the hexagon socket head bolt (2) of the limit switch lever (1) and fix the limit switch lever (1) and the shaft (3) with the hexagon socket head bolt (2) so that the main body of the limit switch can be inclined rightward from the perpendicular by 10 degrees. (Tightening torque 2.45 to 2.65N-m)

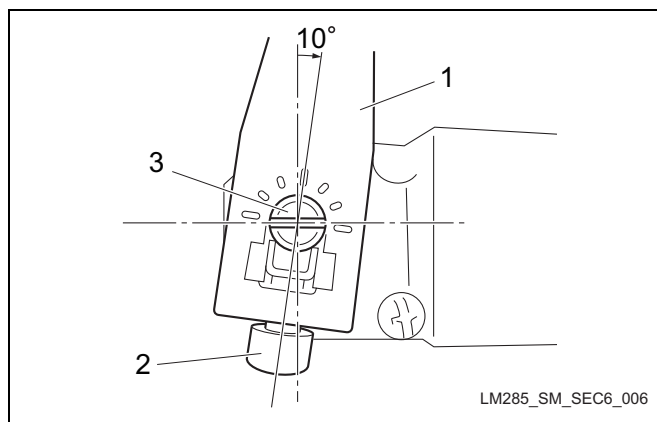

Figure: Electrical system-6-a

1	Limit switch lever
2	Hexagon socket head bolt
3	Shaft

- Fit the lever so that the end of the shaft (1) and the end face of the lever (2) can be leveled.

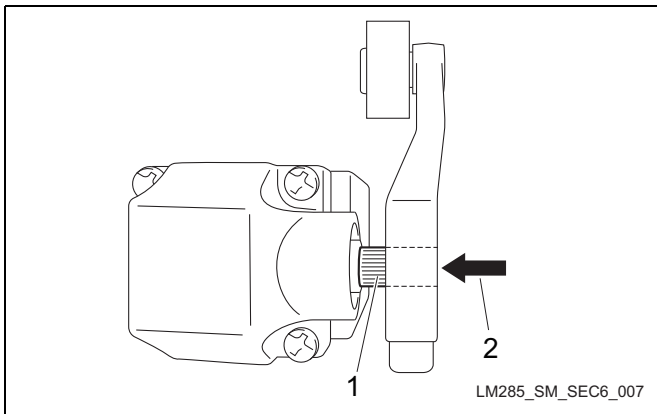

Figure: Electrical system-7-a

1	Shaft
2	End face of the limit switch lever

- When the parking brake is pulled up by 2 to 3 notches, the first stage of the limit switch comes on and it is supposed to click.

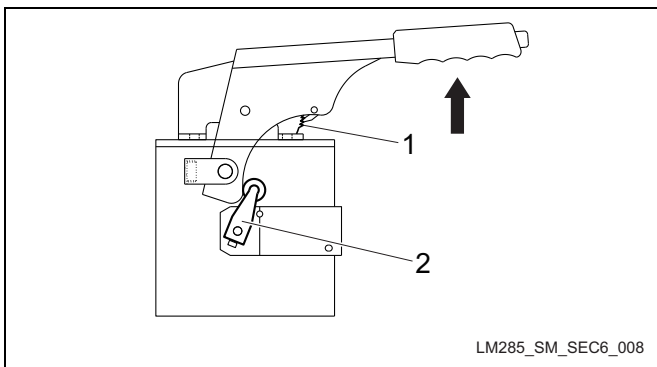

Figure: Electrical system-8-a

1	2 to 3 notches
2	The first stage ON

- When the lever is pulled up further, the second stage of the limit switch comes on. Check if it clicks.

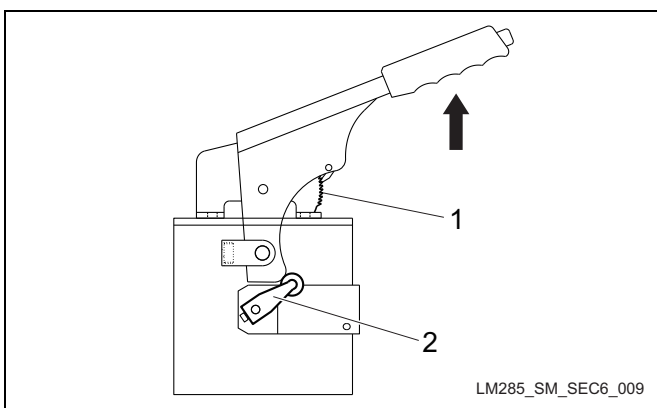

Figure: Electrical system-9-a

1	4 notches or more
2	The second stage ON

- If the first stage of the switch does not come on by 2 to 3 notches, adjust the angle of the limit switch lever.

Reel rotation switch

- When the reel rotation lever (4) is in the neutral position, move the lever in its up/down and/or right/left allowance and check if the reel rotation switch (3) is always ON.
- When the reel rotation lever (4) is in the position of positive or negative rotation, move the lever in its up/down and/or right/left allowance and check if the reel rotation switch (3) is always OFF.
- If adjustments required, loosen the bolt (1) and move the switch mounting plate (2) with the reel rotation switches (3) parallel to the reel rotation lever (4).
- Check if the reel rotation switches (3) are ON when the reel rotation lever (4) is in the neutral position and if the reel rotation switches (3) are OFF when the reel rotation lever (4) is in the positive or negative rotation position. In the above state, exercise care in the position of the switch mounting plate (2) and tighten the bolt (1).
- If one of the reel rotation switches (3) is not ON when the reel rotation lever (4) is in the neutral position, loosen the bolts (5) and adjust the switch so that it can be ON.

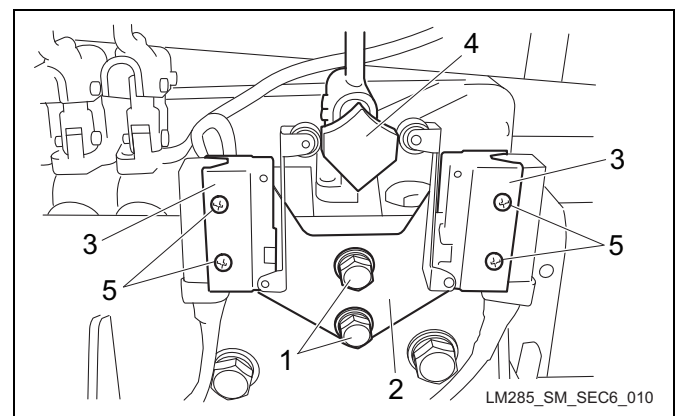

Figure: Electrical system-10-a

1	Bolt
2	Switch mounting plate
3	Reel rotation switch
4	Reel rotation lever
5	Bolt

For the operation check of the reel rotation switch, check if the engine can be started under the conditions of sitting on the seat, applying (pulling) the parking brake and the reel

Electrical system

rotation lever being in the neutral position. And check if the engine cannot be started under the conditions of sitting on the seat, applying (pulling) the parking brake and the reel rotation lever being in the positive or negative rotation position. (Refer to “Interlock system” (Page 6-7))

Neutral switch

1. When the rod for rear wheel (1) is in the neutral position, loosen the nuts (3) and bolts (4) of the switch mounting base (2).

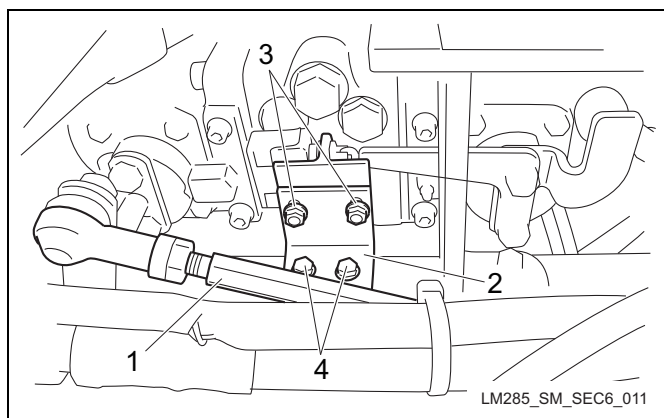

Figure: Electrical system-11-a

1	Rod for rear wheel
2	Switch mounting base
3	Nut
4	Bolt

2. Adjust vertically so that the center of the apical end of the neutral lever (1) can slightly touch the apical end of the neutral switch (2) and lock it with the nuts (3).
3. From the above positioning, adjust in a front-back direction so that the apical end of the neutral switch (2) will be pushed in by 2.5mm (0.10 in) and lock it with the bolts (4).

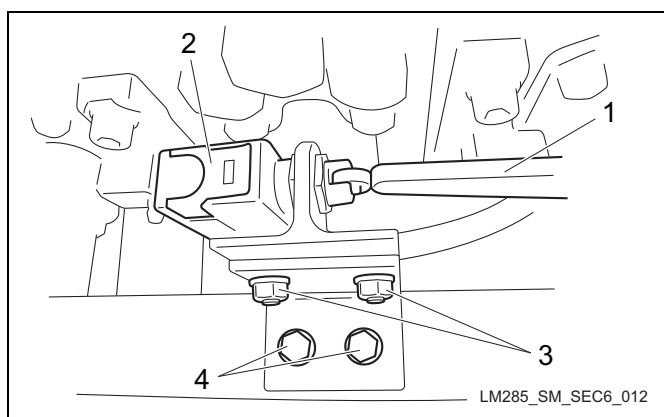

Figure: Electrical system-12-a

1	Neutral lever
2	Neutral switch
3	Nut
4	Bolt

For the operation check of the neutral switch, check if the engine can be started under the conditions of sitting on the seat, applying (pulling) the parking brake and the travelling pedal being in the neutral position. And check if the engine cannot be started when the forward direction of the traveling pedal is depressed. Then check if the engine cannot be started when the reverse direction of the traveling pedal is depressed. (Refer to “Interlock system” (Page 6-7))

Maintenance switch

1. When the reel rotation lever (1) is in the neutral position, loosen the knob (2) and move it to BACKLAPPING side.

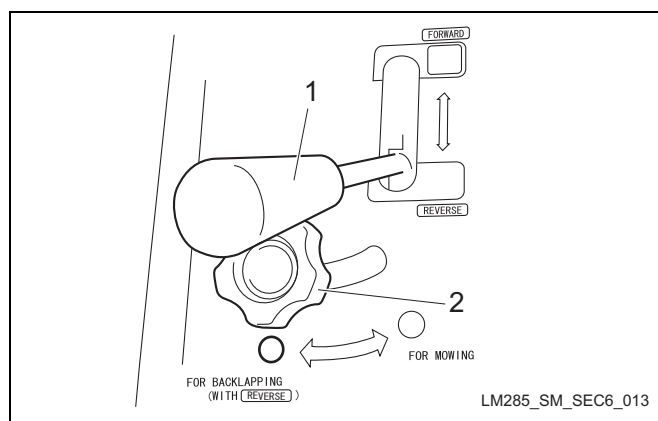

Figure: Electrical system-13-a

1	reel rotation lever
2	Knob

2. Loosen the bolts (2) of the switch mounting plate (1) and tighten the bolts (2) temporarily so that the limit switch hinge lever (3) can slightly touch the stopper (4).
3. From the above positioning, adjust in a front-back direction so that the hinge lever (3) will be pushed in by 4 to 5mm (0.16 to 0.20 in) and lock it with the bolts (2) so that the hinge lever (3) will not touch the main body of the limit switch due to being pushed by the stopper (4).

“MOWING” side

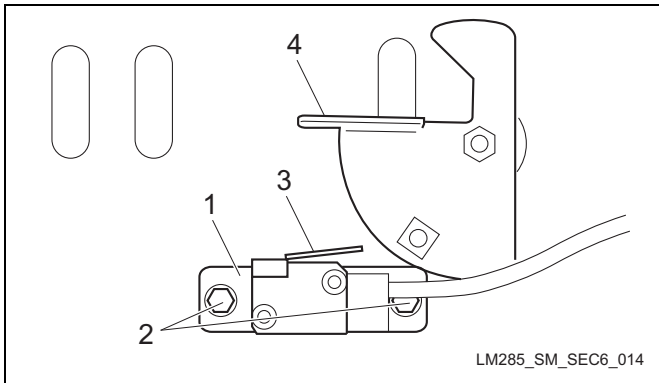

Figure: Electrical system-14-a

1	Switch mounting plate
2	Bolt
3	Limit switch hinge lever
4	Stopper

“BACKLAPPING” side

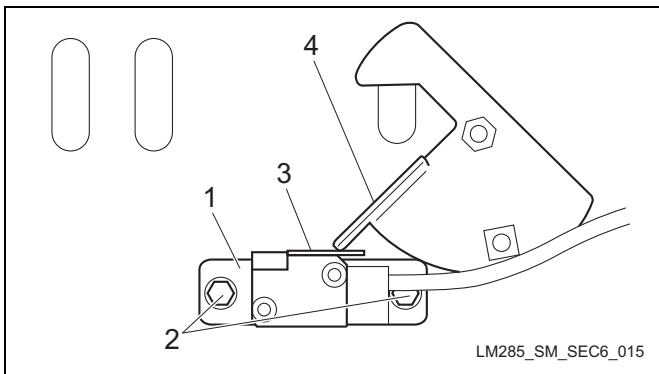

Figure: Electrical system-15-a

1	Switch mounting plate
2	Bolt
3	Limit switch hinge lever
4	Stopper

For the operation check of the maintenance switch, check if the engine can be started under the conditions of sitting on the seat, applying (pulling) the parking brake and the travelling pedal being in the neutral position.

Check if the engine cannot stop even when the operator shifts the reel rotation lever to “BACKLAPPING” side and leaves the seat (Refer to “Interlock system” (Page 6-7))

Proximity switch

During rotating the reels of five mower units, the reel cutters are supposed to stop when the cutting edge of reel cutter and bedknife of #3 mower unit is lifted more than 400mm (15.75 in). Make an adjustment unless it stops under the condition.

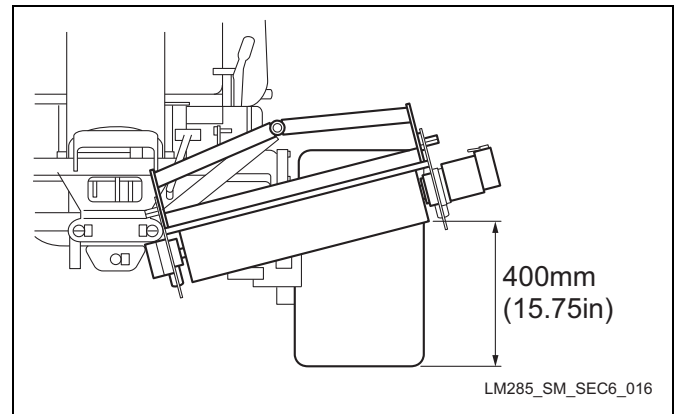

Figure: Electrical system-16-a

Adjust the sensor mounting plate (1) in the right and left direction and lock it with the bolts (2).

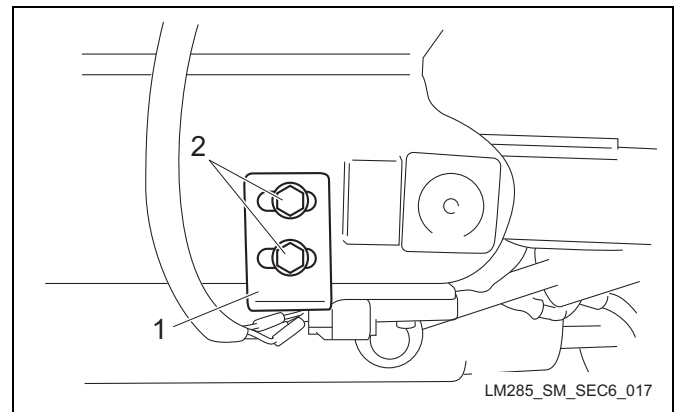

Figure: Electrical system-17-a

1	Sensor mounting plate
2	Bolt

Electrical components

Warning

When servicing electrical components, be sure to disconnect the negative battery cable.

Safety switch

- Components relating to starting and running of the engine.
Seat switch, Parking brake switch, Reel rotation lever switch and Neutral switch
- Component relating to rotation of the reel.
Maintenance switch

Electrical system

Seat switch

The seat switch is positioned beneath the seat and normally not in a conduction state.

It is supposed to be in a conduction state when the seat is occupied (the switch is pushed).

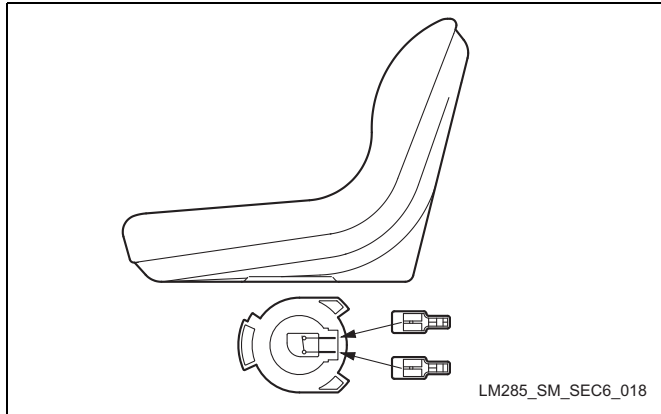

Figure: Electrical system-18-a

Parking brake switch

The parking brake switch is positioned beneath the parking brake lever and a two-stage action type.

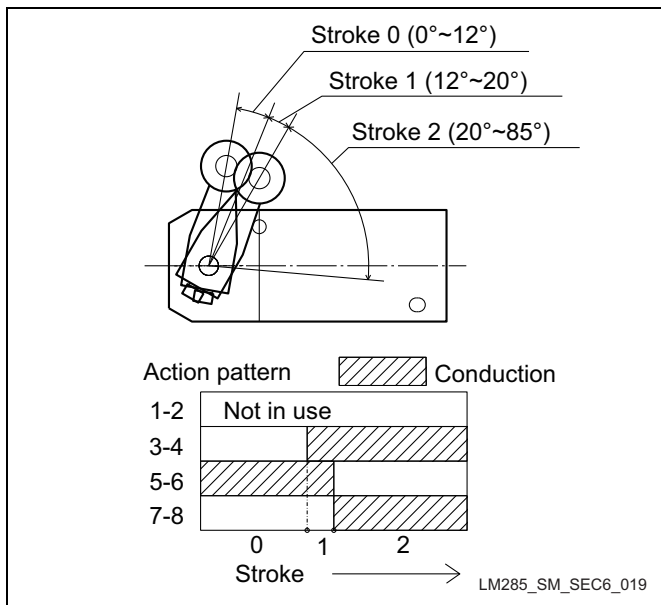

Figure: Electrical system-19-a

It is considered to be normal if it is in a conduction state as follows;

Stroke 0: Conduction between A-C in a state of Not Pulling the parking brake lever.

Stroke 1: Conduction between A-B, A-C and B-C in a state of Slightly Pulling the parking brake lever (2 to 3 notches).

Stroke 2: Conduction between A-B and C-D in a state of Fully Pulling the parking brake lever (4 notches or more).

Conduction state	Conduction		
	0	1	2
A-B		Conduction	Conduction
A-C	Conduction	Conduction	
A-D			
B-C		Conduction	
B-D			
C-D			Conduction

Reference code: LM285_SM_SEC6_020

Figure: Electrical system-20-a

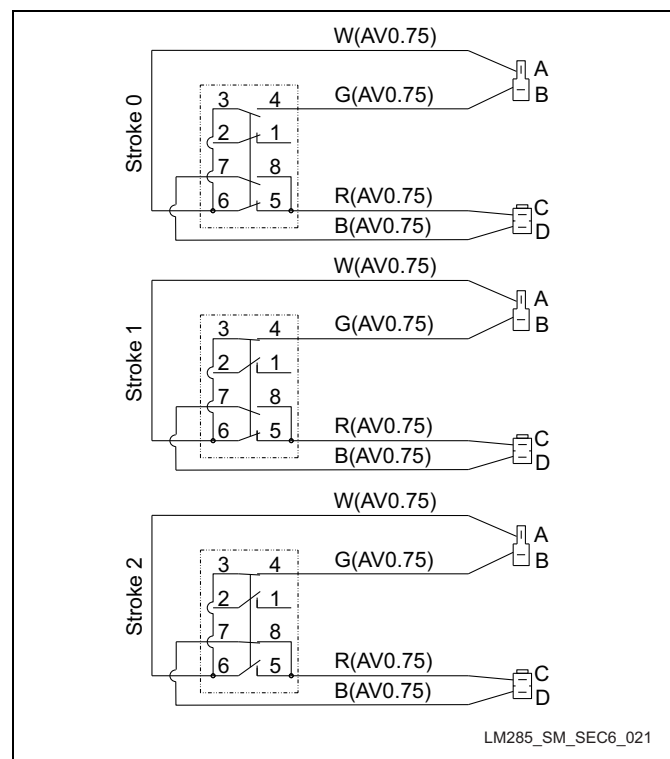

Figure: Electrical system-21-a

Reel rotation switch

The two reel rotation switches are positioned in the reel rotation lever section under the right side front cover.

It is considered normal if the two reel rotation switches are in a conduction state when the reel rotation lever is in the neutral position (pushed) and if they are not in a conduction state when the reel rotation lever is in FORWARD and REVERSE positions (returned).

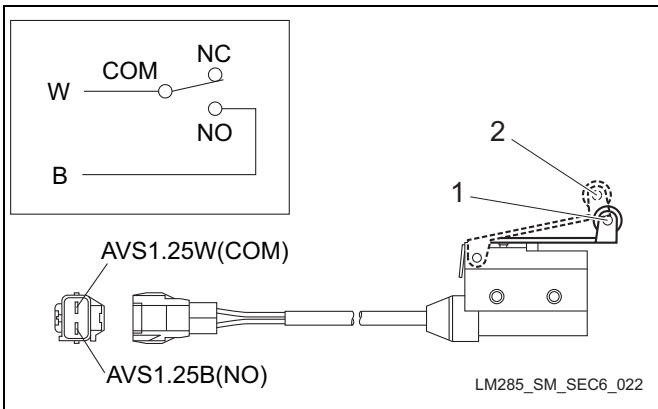

Figure: Electrical system-22-a

1	Neutral
2	"FORWARD" and "REVERSE"

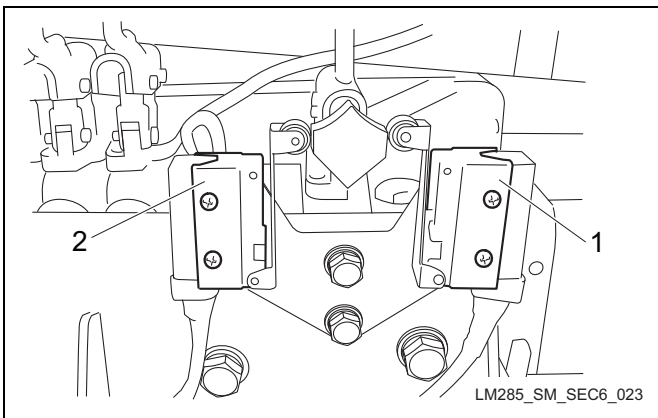

Figure: Electrical system-23-a

1	For engine stop solenoid
2	For starter motor

Neutral switch

The neutral switch is positioned in the hydraulic pump neutral lever section. It is considered to be normal if it is in a conduction state under the condition of the traveling pedal being in the neutral state (pushed) and not in a conduction state under the conditions of the traveling pedal being in the forward and reverse state (returned).

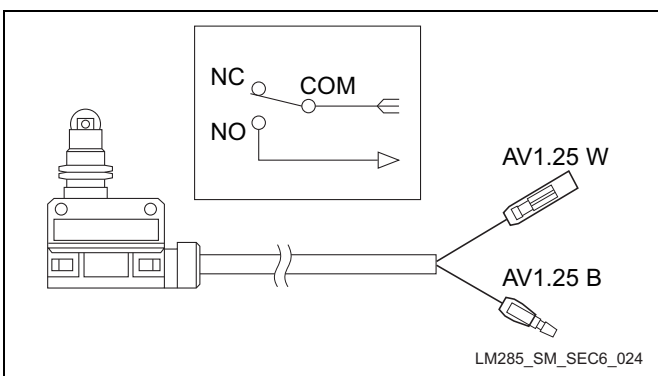

Figure: Electrical system-24-a

Maintenance switch

The maintenance switch is positioned on the reverse side of the right side front cover. It is considered to be normal if it is not in a conduction state under the condition of the prevention stopper from reel negative rotation being in the "MOWING" state (returned) and in a conduction state under the condition of the stopper being in the "BACKLAPPING" (pushed).

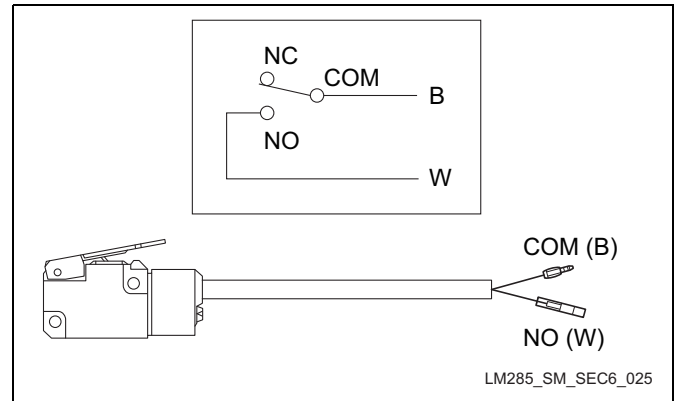

Figure: Electrical system-25-a

Proximity switch

The proximity switch (1) is positioned in #3 mower arm mounting section of the frame and the plastic magnet for detection (2) is attached to #3 mower fulcrum section. It is normal if you obtain the following check results.

In the state of #3 mower being lowered (the proximity switch detects the magnet), there is no battery voltage (0V) between the vehicle body (earth) and 4 (black and white cord) of the connector (4) removed from the relay (on the under side under the right side front cover) and in the state of #3 mower being raised (the proximity switch does not detect the magnet), there is battery voltage (12V) between the vehicle body (earth) and 4 (black and white cord) of the connector (4).

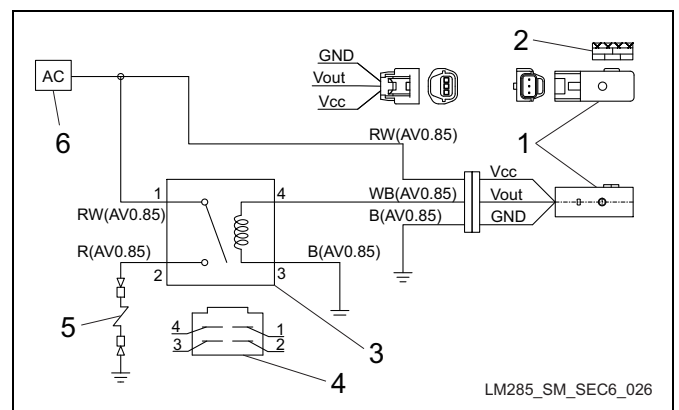

Figure: Electrical system-26-a

Electrical system

1	Proximity switch
2	Plastic magnet for detection
3	Relay
4	Connector

Solenoid valve

The solenoid valve is attached to the manifold with solenoid valve and positioned under the front cover. It is activated according to the detection of the proximity switch.

The solenoid valve switches the hydraulic circuit inside the manifold so that the gear motors of the mower units can rotate or stop. In a state of no battery voltage in the hydraulic circuit, the gear motor is supposed to rotate.

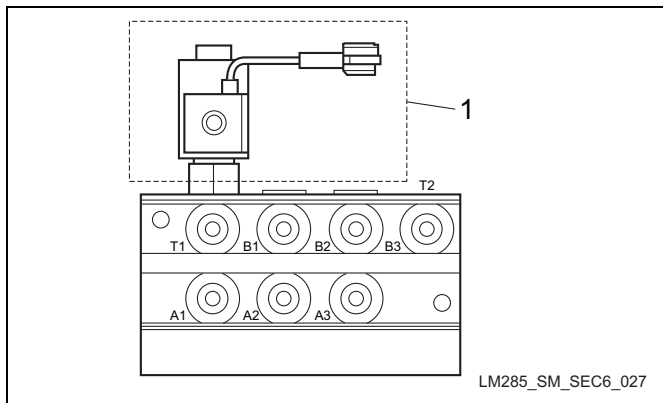

Figure: Electrical system-27-a

1	Solenoid valve section
---	------------------------

Solenoid specifications

Voltage	Resistance	Holding current
DC12V	5.2Ω	2.33A

Key switch

The key switch is used for start and stop of the engine. Conduction in each position is as follows;

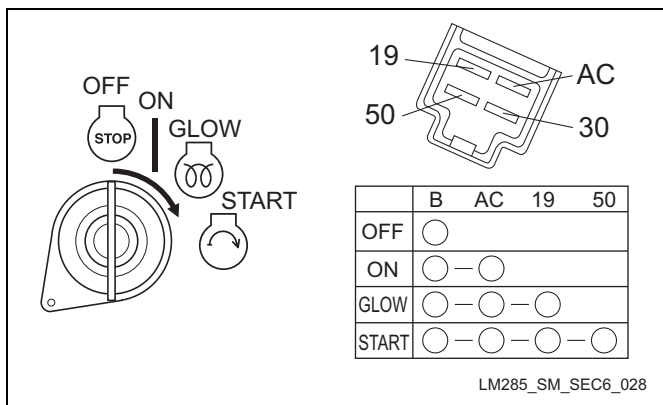

Figure: Electrical system-28-a

Positions of the key and actions of the components

■ ON (Run)

The diesel engine installed in this vehicle controls run and stop according to existence or non-existence of fuel supply.

In the key position “OFF,” the engine stop solenoid stops and fuel supply is cut. During holding “ON” after start of the engine, the solenoid acts and fuel is supplied.

(The solenoid is a normally-current-carrying type: during run = conduction)

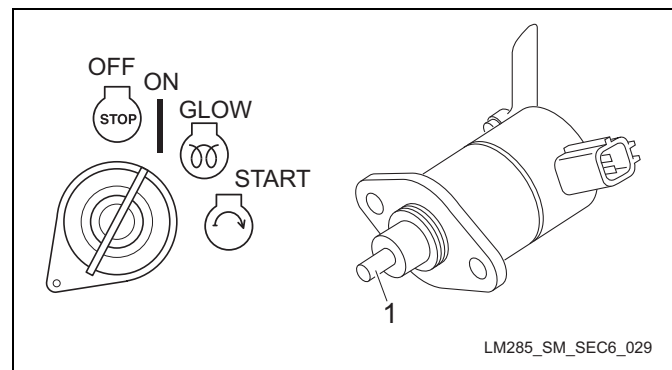

Figure: Electrical system-29-a

1	Plunger
	Key “OFF” plunger (projected)
	Key “ON” plunger (retracted)

■ Glow (Thermo-start)

Hold the key position “GLOW” and the glow plug will generate heat and the thermo-start lamp will light up.

The lamp blacks out after the set time, but the extinction of the lamp does not relate to the heat generation of the glow plug. Even after the lamp extinction, it generates heat if the key position is “GLOW”. The lighting time of the thermo-start lamp is 5 seconds.

The glow plug is positioned in each cylinder head of engine and connected with a plate. The electrical circuit is engine block earth.

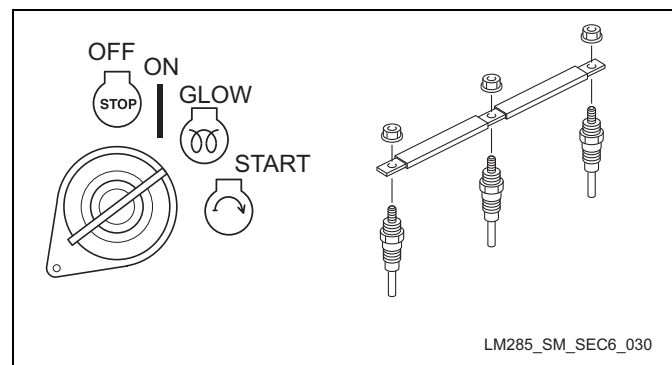
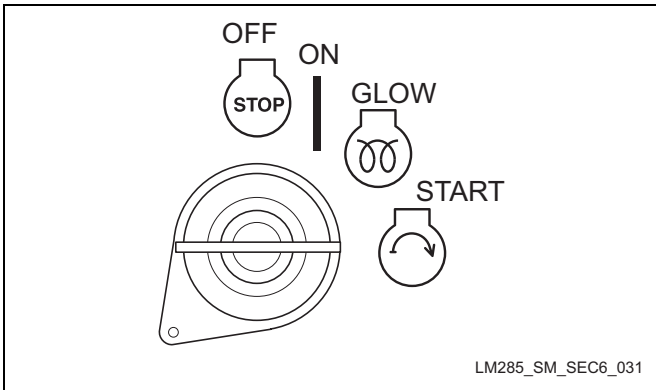

Figure: Electrical system-30-a

■ START

In the key position “START,” the current is carried to the magnet switch of the starter motor and the starter motor rotates and starts the engine.

The switch is connected to the starter motor through the safety switches in three locations. If the safety switches do not operate, the starter motor does not rotate.



LM285_SM_SEC6_031

Figure: Electrical system-31-a

Pilot lamp

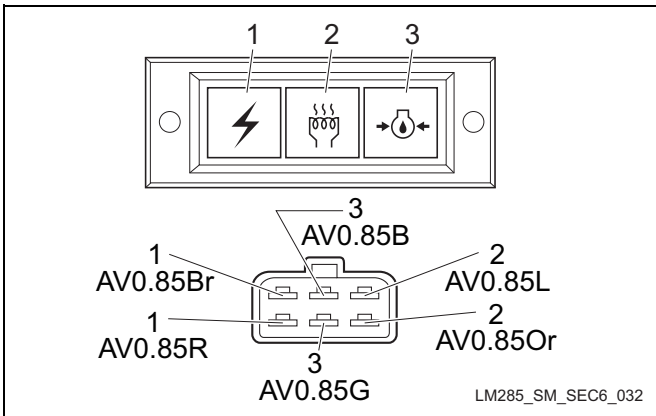

LM285_SM_SEC6_032

Figure: Electrical system-32-a

1	Charge
2	Thermo-start
3	Engine oil pressure

■ Charge

The lamp lights up in the key position “ON” before start of the engine and blacks out after the engine starts and the alternator operates normally. Before the engine starts, the current is carried to IG plug (yellow cord) of the alternator in the key position “ON,” L plug (brown=charge lamp earth) grounds in the inside circuit of the alternator and the lamp lights up. After the normal operation, the inside circuit earth of L plug is cut and the lamp blacks out. It is grounded to the engine block.

In case that the charge lamp lights up during engine run, charge trouble may occur due to defect on the alternator drive belt or the IC regulator inside the alternator.

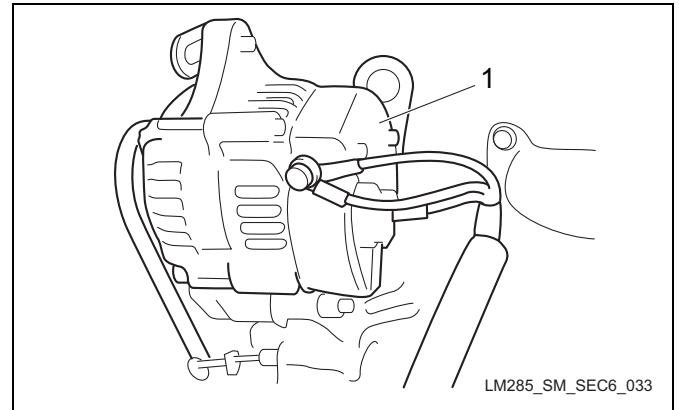

LM285_SM_SEC6_033

Figure: Electrical system-33-a

1	Alternator
---	------------

■ Thermo-start

The lamp lights up in the key position “GLOW” when the glow plug generates heat. The glow lamp timer controls the light up period of the thermo-start lamp and the lamp blacks out after the set time. The light up period is 5 seconds for preheating.

■ The engine oil pressure

The lamp lights up in the key position “ON” before start of the engine and it blacks out when the oil pressure is normally placed after the engine starts. The lamp is connected to the oil pressure switch positioned in the engine block (in the side of the oil element) and lights up when the oil pressure is reduced during run.

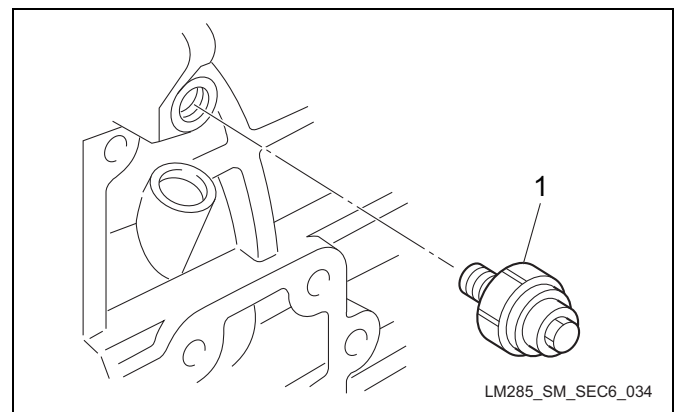

LM285_SM_SEC6_034

Figure: Electrical system-34-a

1	1 Oil pressure switch
---	-----------------------

Electrical system

Fuel gauge

The fuel gauge is positioned in the upper right of the operation panel and connected to the fuel unit of the fuel tank. It indicates the fuel level according to the up-down movement of the float installed in the fuel tank.

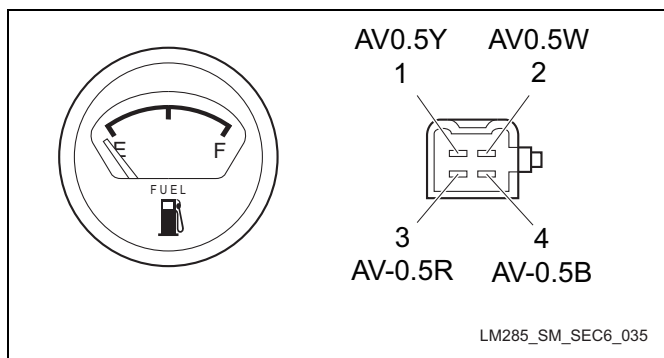

Figure: Electrical system-35-a

1	Illumination + (not in use)
2	Fuel unit
3	IGN +
4	Earth

Water temperature gauge

The water temperature gauge is connected to the water temperature sensor (1) positioned in the engine block (rear right side of the vehicle) and indicates the water temperature.

The water temperature sensor converts the resistance value according to the fluctuation of the temperature and indicates the temperature.

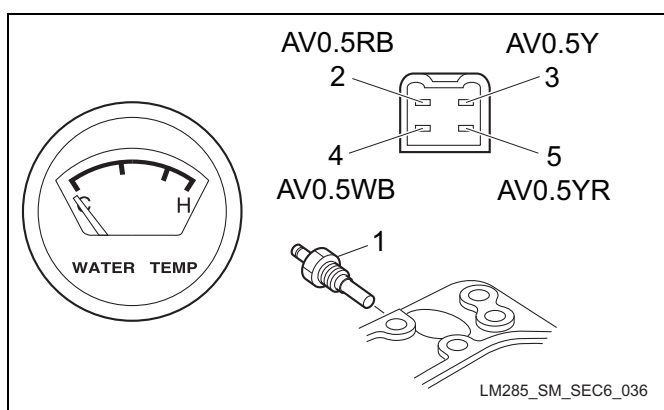

Figure: Electrical system-36-a

1	Water temperature sensor
2	Illumination + (not in use)
3	IGN +
4	Earth
5	Electric wire of water temperature sensor

Tachometer, Hour meter

The tachometer is positioned in the left side of the operation panel, connected to the rotation sensor of the engine flywheel section and indicates the rotation number with the signal output from the rotation sensor.

The hour meter indicates the total number of hours the engine has run. The number (black figures on a white background) is incremented every six minutes and the next number (white figures on a black background) is incremented every hour.

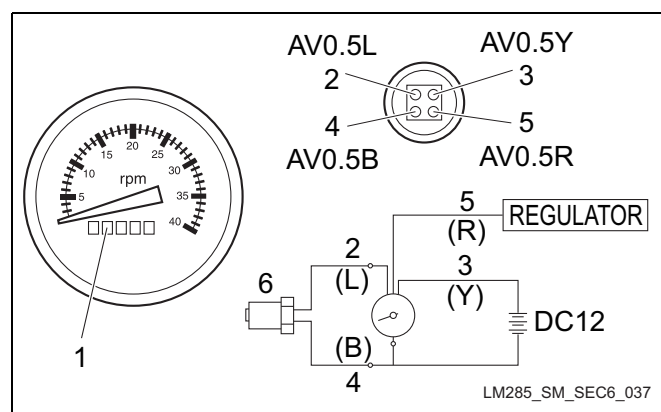

Figure: Electrical system-37-a

1	Hour meter
2	Tachometer pulse
3	Tachometer electric wire+
4	Earth
5	Hour meter electric wire+
6	Rotation sensor

Starter relay

The starter relay is positioned in the right side under the front cover and controls the availability of start of the starter motor with the signal of the safety switch.

The wire from the safety switch is connected to L plug of the alternator (Earth when starting) through the relay. The starter motor can start only when the safety switch and the alternator operate normally.

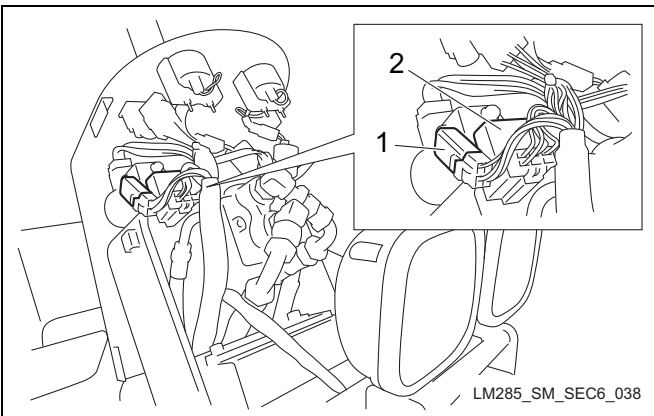

Figure: Electrical system-38-a

1	Starter relay
2	Glow lamp timer

Glow lamp timer

The glow lamp timer is positioned in the right side under the front cover and controls the lighting of the thermo-start lamp.

Hold the key position “Glow” and the thermo-start lamp will light up for 5 seconds. The timer unit operates with the signals of “glow” and “starter motor start” from the key switch. When the glow signal (green cord) is input, the thermo-start lamp lights up (for 5 seconds). Even within the light-up period (5 seconds) of the thermo-start lamp, the lamp may black out when the key is shifted to the position “start” (starter motor start) and the start signal (white cord) of the starter motor is input. If the timer unit trouble occurs, the lamp does not light up. However it does not influence the start of the engine.

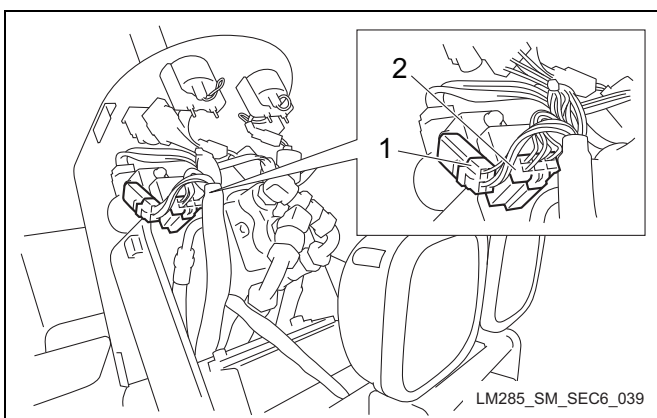

Figure: Electrical system-39-a

1	Starter relay
2	Glow lamp timer

Timing chart

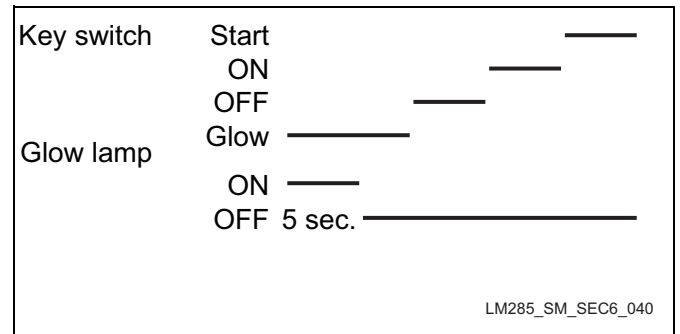

Figure: Electrical system-40-a

Fusible link

The fusible link works as the main fuse of the whole circuit and the fuse of the charge circuit.

It is positioned in the front left side under the left side bonnet and has a cartridge fuse for exclusive use (50A).

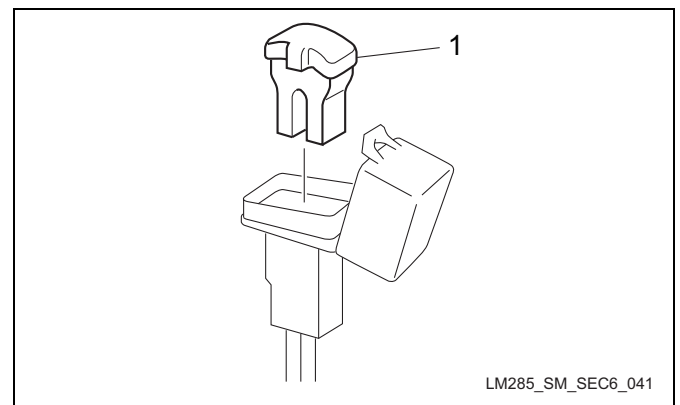

Figure: Electrical system-41-a

1	Fuse for exclusive use
---	------------------------

Fuse box

It is positioned in the front left side under the bonnet and is connected to each electrical component through fuses from the key switch. The standard of the fuse for use is “mini fuse for a car.”

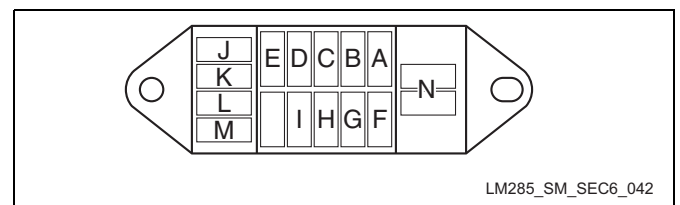

Figure: Electrical system-42-a

Electrical system

A	5A	Proximity sensor, Solenoid for reel rotation stop
B		Charge lamp, Oil pressure lamp, Water temperature gauge, Buzzer, Hour meter, Rotation gauge, Fuel gauge
C		Fuel pump
D		Glow lamp
E		Glow lamp timer
F		Starter relay
G		Solenoid for engine stop
H		Alternator (IG)
I		Glow lamp timer
J		Spare
K		
L		
M		
N		

Replacement of fuses

Important

For removal of a fuse, use the tool inside the box.

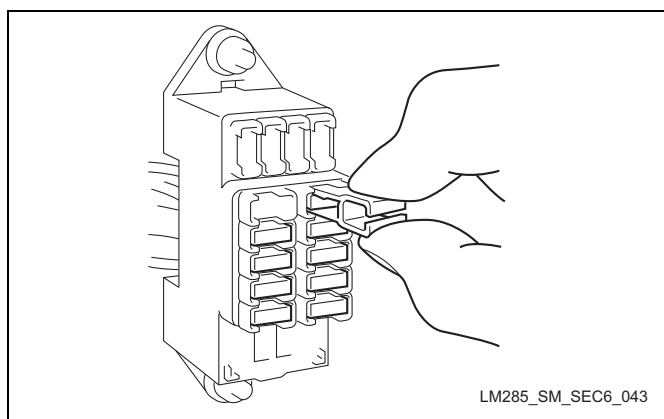

Figure: Electrical system-43-a

Fuel pump

The fuel pump is positioned on the frame in the left side of the fuel tank and has a solenoid, diaphragm and check valve etc. inside. Its power source is DC12V.

Shift the starter switch to “ON” position and the current will be carried to the solenoid and the diaphragm will operate. As a result, it repeats intake and discharge of fuel

and supplies a certain quantity of fuel to the injection pump with no relation to the engine rotation.

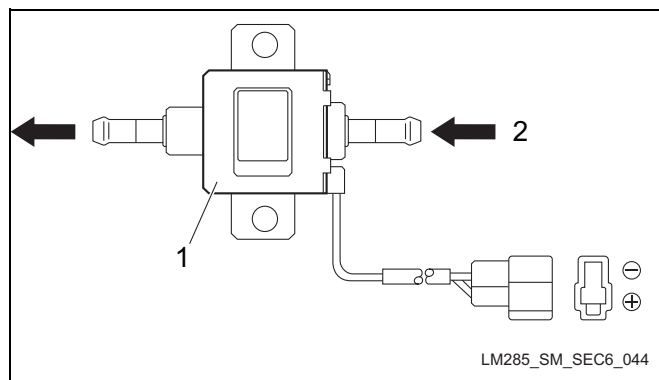

Figure: Electrical system-44-a

1	Fuel pump
2	Fuel

Specifications

Rated voltage	DC12V
Rated current	1.5A
Discharge rate	400cc/min

Fuel unit

The fuel unit is positioned on the upper side of the fuel tank and connected to the fuel gauge. It converts the up-down movement of the float installed in the fuel tank to the resistance value and measures the fuel level.

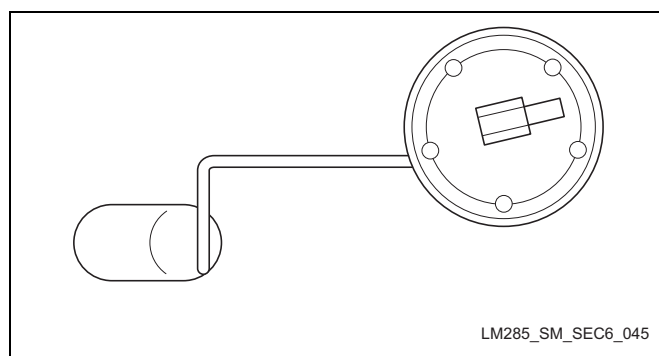

Figure: Electrical system-45-a

Rotation sensor (Electromagnetic pick up)

The rotation sensor (Electromagnetic pick up) is positioned in the upper section of the engine flywheel and detects the rotation frequency from the flywheel ring gear. And then it sends the signal to the tachometer to indicate the rotation frequency.

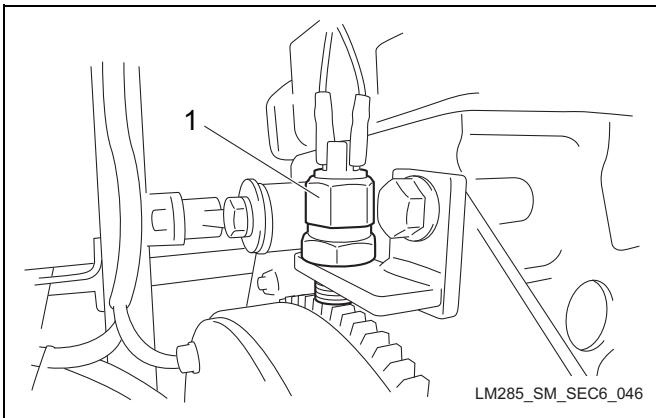

Figure: Electrical system-46-a

1	Rotation sensor
---	-----------------

Buzzer

The buzzer is for warning of water temperature and connected to the thermo-switch of the engine side. The thermo-switch is positioned on the side of the flange in the upper connecting section of the radiator hose.

When the temperature comes up to the preset temperature, the thermo-switch let the current be carried to the engine block

and the buzzer rings. The preset temperature is 105 degrees C. As for the circuit of this vehicle, the engine will not stop even if it comes up to the preset temperature.

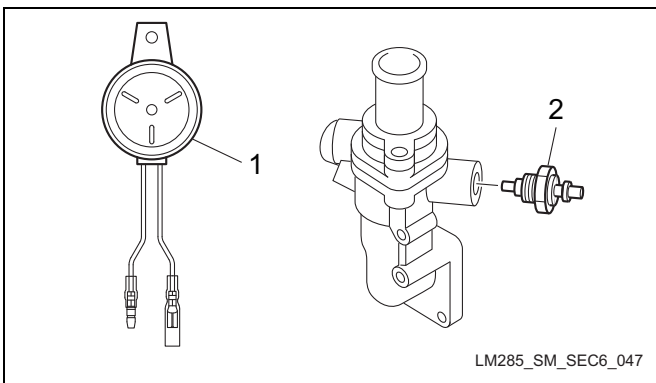

Figure: Electrical system-47-a

1	Buzzer
2	Thermo-switch

Light switch

The light switch (1) is positioned in the left side under the operation panel. It is considered normal if there is electric continuity (“ON”) when the lever is shifted upward and if there is no electric continuity (“OFF”) when the lever is shifted downward.

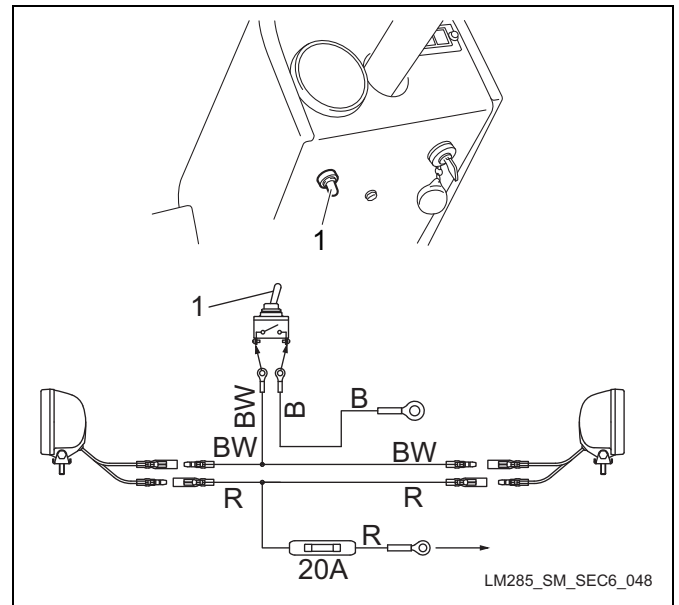

Figure: Electrical system-48-a

1	Light switch
---	--------------

General inspection and repair

Battery

For details on handling the battery, refer to the instruction manual provided with it.

Handling of the battery

For safe use of the battery, observe the following precautions.

⚠ Danger

Do not handle the battery near open flames or in a poorly ventilated area. Keep the battery away from lit cigarettes and other open flames. Do not short-circuit the battery. The battery will short-circuit if the positive and negative terminals are connected to each other by a metallic tool, a short-circuit will also result if the positive terminal contacts another metallic part (machine body etc.).

1. Keep the battery away from open flames. Hydrogen gas may be generated from the battery. Improper handling of the battery could cause a fire or explosion.

Electrical system

Danger

Do not throw, drop, tilt or upset the battery, or allow it to undergo physical impact. Doing so could cause the electrolyte to leak. If contact of the electrolyte with the eye, skin, or clothing occurs, immediately wash it off with plenty of water. In particular, if eye contact or ingestion occurs, immediately seek medical treatment. If the electrolyte spills over the machine etc., wipe away with a wet cloth and flush the affected area with plenty of water.

2. The electrolyte contained in the battery is sulfuric acid. Contact of the electrolyte (sulfuric acid) with the skin could cause blindness or burns. Contact of the electrolyte with the machine etc. could cause damage to the machine.

Danger

Do not allow anyone to handle the battery who does not fully understand the correct battery handling procedures and relevant dangers. When handling the battery, wear protective glasses and rubber gloves, etc.

If the battery has an unusual odor, the electrolyte level goes down unusually fast, or the electrolyte leaks, do not continue to use the battery. Doing so could cause a fire or explosion, etc.

Caution

If the electrolyte overflows, neutralize it with bicarbonate etc. until the bubbles disappear, and wash out with plenty of water. Failure to do so could cause corrosion of the surrounding area or environmental pollution.

If deformation of the exterior of the battery is observed, do not continue to use it. Doing so could result in damage to the battery or electrolyte leaks.

3. Use extra care when handling the battery, and if any problems are found, replace the battery with a new one. Carry or store the battery with care so that it does not fall or become damaged.

Inspection of the battery

To ensure safe use of the battery, inspect it at least once a month.

Before inspecting the battery, be sure to stop the engine and remove the key.

Danger

Do not allow anyone to handle the battery who does not fully understand the correct battery handling procedures and relevant dangers.

When handling the battery, wear protective glasses and rubber gloves, etc. The electrolyte may cause blindness or burns.

Never use an open flame when inspecting the battery. Do not connect the positive and negative battery terminals to each other using a metallic tool etc. Doing so could cause a fire or explosion.

Always keep the electrolyte level above the LOWER (minimum level line) limit. Failure to do so could cause the battery life to be shortened or cause explosion.

Loose connections between cable and terminal, or corroded terminals could cause a fire or explosion.

Warning

Before handling the battery such as for purposes of inspection etc., touch a metal part of the machine body with your bare hand in order to remove static electricity.

Static electricity could cause a fire. When cleaning the battery, do not use dry cloth or tissue paper, etc. Static electricity could cause a fire.

When adding distilled water, keep the electrolyte level below the UPPER (maximum level line) limit. Failure to do so could cause the electrolyte to leak.

Caution

If the electrolyte overflows from the battery, wipe it with a wet cloth. Failure to do so could cause damage to the instruments.

When cleaning the battery, do not use organic solvents such as benzene, thinner or gasoline and refrain from using cleaner, or chemical cloth. Doing so could damage the battery case, resulting in electrolyte leaks.

Do not add anything but distilled water to the battery. Adding anything other than distilled water could cause the battery to become extremely hot or generate toxic gases due to impurities.

Do not add sulfuric acid to the battery. Doing so could cause the specific gravity of the electrolyte to exceed the specified value, causing the battery life to be shortened.

After adding distilled water to the battery, firmly tighten the vent plug.

When inspecting the battery, inspect the following items.

1. Visual inspection

Visually inspect the battery case for cracks, chips and deformation, and check that there are no electrolyte leaks. If any of the above are found, investigate what has caused them and replace the battery.

2. Cleaning of the exterior

When cleaning the battery, use cloth that has been dampened with water.

Inspect the vent plug or vent hole on the side. If the plug or hole is clogged with mud etc., wash it with water. A clogged vent hole could cause the internal pressure to increase due to gases generated inside the battery, causing the battery to burst.

3. Inspection of the mounting bracket

Ensure that the battery is firmly secured by the mounting bracket. If it is not, tighten the nuts securing the battery until it is firmly secured. If the battery is not firmly secured by the mounting bracket, the battery could move due to vibration while the machine is moving, resulting in damage to the battery case or electrolyte leaks.

4. Inspection of the cable terminals for looseness

If a connection between a battery terminal and machine-side cable terminal is loose, tighten the nut securing the cable terminal until it is firmly secured. Loose connections could result in an insufficiently charged battery, damaged terminals, or explosion.

Reference: If a terminal has corroded, polish it using a wire brush or fine sandpaper, and apply a small amount of anti-rust grease.

5. Inspection of the electrolyte level and addition of distilled water

Important

When adding distilled water, be careful not to add an excessive amount.

Check the electrolyte level by looking from the side of the battery. If the electrolyte level has fallen to less than halfway between the "UPPER" (maximum level line) and "LOWER" (minimum level line) limits, add distilled water to the battery immediately until the "UPPER" limit is reached.

When adding distilled water, loosen and remove the vent plug and add distilled water up to the "UPPER" (maximum level line) limit.

After adding distilled water, firmly tighten the vent plug.

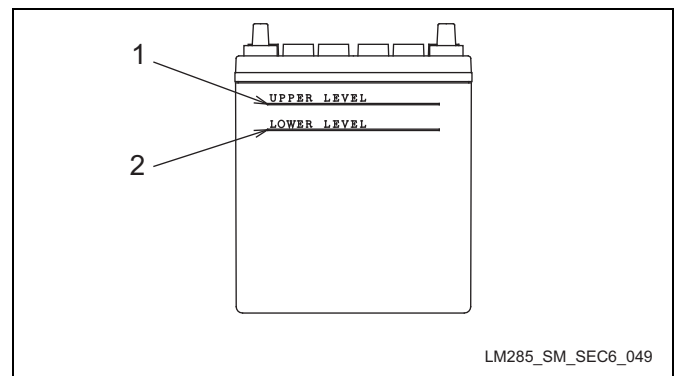

LM285_SM_SEC6_049

Figure: Electrical system-49-a

1	Upper limit
2	Lower limit

Replacement of the battery

When replacing the battery, note the following precautions and be sure to turn off the power switch etc., stop the engine, and remove the key before replacement.

Electrical system

Danger

Do not replace the battery near open flames or in a poorly ventilated area. Keep the battery away from lit cigarettes and other open flames. Failure to observe these precautions could cause a fire or explosion.

Do not short-circuit the battery. If the positive and negative terminals are connected to each other by a metallic tool the battery will short-circuit, a short-circuit will also result if the positive terminal contacts another metallic part (machine body etc.).

When connecting a machine-side cable terminal to a battery terminal, ensure that the nut is firmly tightened. A loose nut could cause a fire or explosion.

Warning

When connecting the machine-side cable terminals to the battery, ensure that they are correctly connected to the positive and negative terminals.

Secure the battery firmly with the mounting bracket. Failure to do so could cause damage to the battery, leakage of the electrolyte, fire or explosion.

Do not modify the battery terminals.

Ensure that the vent plug or vent hole on the side of the battery is not covered by the connection cables etc.

Do not connect any electrical devices directly to the battery.

Caution

Select a battery that has the same terminal positions (the positions of the positive and negative terminals) as the old one. Installing a battery that has different terminal positions could cause damage to the cables.

Do not use organic solvents such as benzene, thinner or gasoline and refrain from using cleaners.

Do not allow the battery to come in contact with vinyl chloride containing plasticizer etc.

When handling the battery, keep it in a horizontal position and install it on the mounting so that it is horizontal.

If the battery has terminal covers or heat shield plates attached, re-install them in their original positions after replacing the battery.

When mounting the battery on the machine, never hold the battery terminals. Doing so could cause the terminals to deform, resulting in poor connections or electrolyte leaks from around the terminals.

Caution

Replace the battery with one that is the same size.

When replacing the battery, follow these steps.

■ **Removing the old battery**

Important

Be careful when handling the used battery as it still contains electrical energy.

1. Stop the engine and remove the key.
2. Disconnect the negative cable (1).
3. Disconnect the positive cable (2).

- Loosen the mounting bracket and remove the old battery.

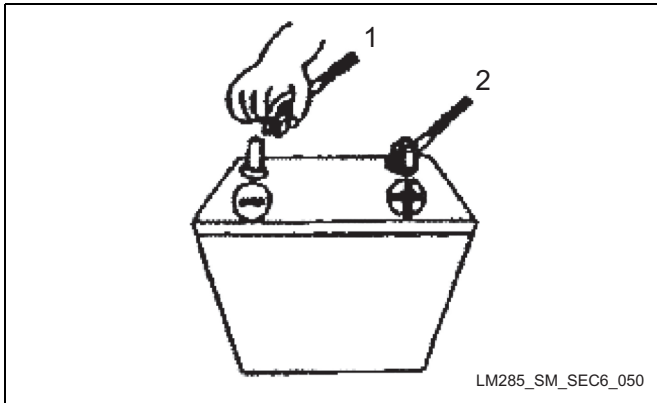

Figure: Electrical system-50-a

1	Negative (-) cable
2	Positive (+) cable

■ Installing a new battery

- Install the new battery with the correct polarities and firmly secure the battery with the mounting bracket (1).

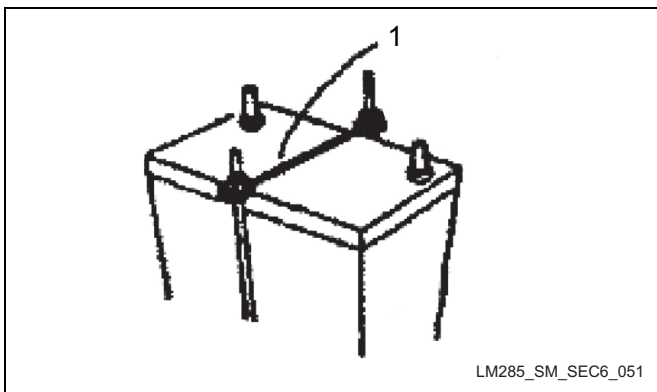

Figure: Electrical system-51-a

1	Mounting bracket
---	------------------

- Remove the protection cap from the new battery.
- Firmly secure the positive cable (1) to the positive terminal (2).

- Firmly secure the negative cable to the negative terminal (3).

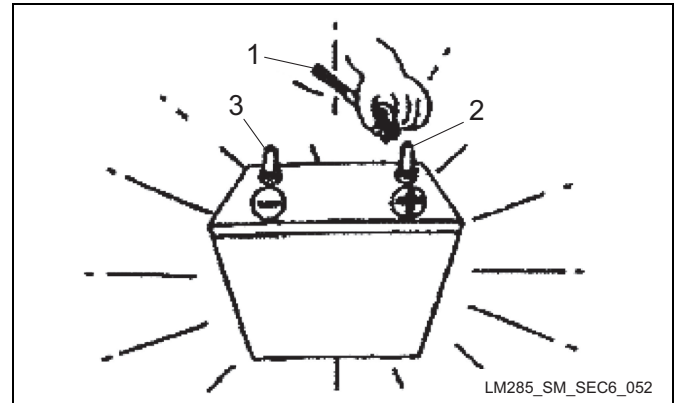

Figure: Electrical system-52-a

1	Positive (+) cable
2	Positive (+) terminal
3	Negative (-) terminal

Battery charging

When charging the battery with a battery charger, follow the instructions described in the instruction manual provided with the battery charger.

⚠ Danger

Do not charge the battery near open flames or in a poorly ventilated area. Keep the battery away from lit cigarettes and other open flames. Failure to observe these precautions could cause a fire or explosion.

Do not connect the battery clip to the battery, or disconnect it from the battery during charging with the battery charger switched on. Doing so could cause a fire or explosion.

If the battery charger is equipped with a voltage selection switch, select the appropriate voltage range. Failure to do so could cause the battery charger to become extremely hot, resulting in a fire or explosion.

Electrical system

Warning

Charging the battery while it is mounted on the machine could cause a fire or explosion, or damage to the machine or its instruments. If unavoidable, be sure to disconnect the negative battery cable from the machine.

When connecting the battery charger to the battery, firmly secure the positive clip to the positive battery terminal and the negative clip to the negative battery terminal. Wrong or loose connections could cause a fire or explosion, cause the battery charger to fail, or cause a polarity inversion, resulting in damage to the machine or its instruments.

Set the charging current to one tenth of the rated capacity or less. For a quick charge, set the charging current to the rated capacity or less. An excessive charging current could cause the electrolyte to leak or become dry, resulting in a fire or explosion.

Do not mount the battery on the machine immediately after charging is completed. First, leave the battery for 30 minutes. Failure to do so could cause a fire or explosion.

Important

If the electrolyte gets extremely hot, the electrode plates or other parts in the battery could deteriorate, resulting in a shorter service life.

Important

Quick charge is not recommended for charging batteries that have been left unused for a long period of time.

Caution

While charging the battery, keep the electrolyte temperature below 45°, or for a quick charge, below 55°. Failure to do so could cause the battery to deform or cause the electrolyte to leak.

When charging the battery, remove the vent plug if it is detachable so that the hydrogen gas generated can disperse more easily. Avoid electrolyte on the vent plug contacting the skin or clothing.

If the electrolyte level has fallen to less than halfway between the "UPPER" and "LOWER" limits, add distilled water to the battery immediately until the "UPPER" limit is reached. Adding distilled water to above the "UPPER LEVEL" could cause the electrolyte to leak.

Maintenance	7-2
Specifications	7-2
Tire pressure	7-2
Adjusted value	7-3
Special tools	7-4
Usage	7-5
Removal and installation of each section	7-6
Wheel	7-6
Brake	7-7
Steering	7-8
Axle	7-9
Seat	7-13
Fuel tank	7-15
Lift arm	7-16
Cover	7-17
Lever damper	7-22
Inspection and repair of each section	7-22
Tire	7-22
Brake	7-23
Brake wire, rod	7-24
Traveling cable, Rod	7-25
Throttle wire, rod	7-27
Toe-in	7-29

Main body

Maintenance

This chapter describes the main inspection and maintenance methods of the LM285 main body. Refer to the LM285 Owner's manual and parts catalog for daily inspection, maintenance and handling of this equipment.

Danger

Follow the instructions below for safe inspection and maintenance.

1. Move the equipment to a level surface to prepare for adjustment and maintenance. Apply the parking brake, stop the engine and remove the key. Make sure that each part has completely stopped its motion before starting procedures for adjustment, maintenance and so on.
2. Do not touch moving parts. Avoid adjustment as much as possible while the engine is running. Keep people away from the area.
3. Use an appropriate chain block, hoist and jack as needed. Securely support the lifted machine with a jack stand or an appropriate block.
4. Use BARONESS genuine parts for replacement parts and accessories.
5. Never start the engine in an enclosed room, for poisoning by carbon monoxide may occur.
6. Never touch the exhaust system while the engine is running or right after the engine has stopped. Its high temperature may cause a burn.
7. Keep flames away from the battery. Batteries emit hydrogen gas and mishandling may cause an explosion.
8. The electrolytic solution in the battery is sulfuric acid. Contact with the electrolytic solution (sulfuric acid) may cause blindness or a burn. Also, it may damage the vehicle if it comes into contact with it.

Specifications

Tire pressure

		Size	kPa	kgf-cm ²	psi=lb-in
STD	Rough front wheel	23×10.50-12 4P	120	1.22	17.40
	Rough rear wheel	23×8.50-12 4P	150	1.53	21.76
Option	Front whee	24×13.00-12 4P	120	1.22	17.40
	Rear wheel	23×8.50-12 4P	150	1.53	21.76

STD rough tire (front wheel, rear wheel)

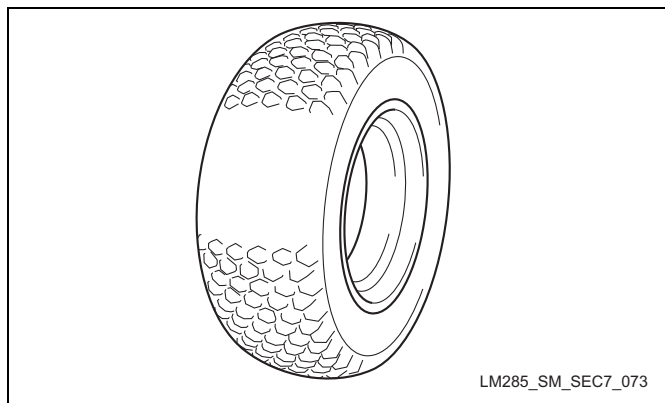

Figure: Main body-1-a

Option (front wheel)

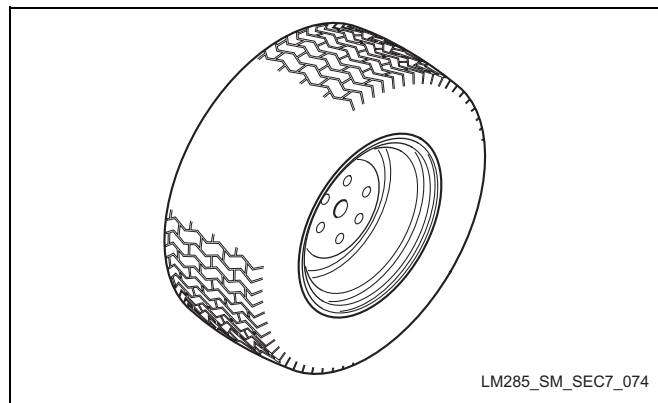

Figure: Main body-2-a

Option (rear wheel)

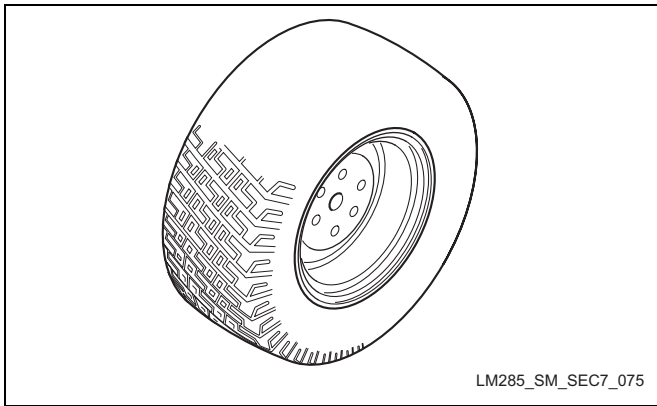

Figure: Main body-3-a

Adjusted value

		mm	in
Toe-in		0±5	0±0.20
Traveling pedal rod distance (Distance between the centers of rod ends)	Rod for the front wheel	334	13.15
	Rod for the rear wheel	567	22.32
	Pedal neutral rod	419	16.50
Spring compression distance (Traveling pedal section)	Compression spring of the pedal side	100	3.94
	Compression spring of the pump side	75	2.95

Adjustment of Toe-in

For the adjustment method, refer to “Toe-in” (Page 7-29).

Adjustment of the traveling pedal rod

The adjusted value of the traveling pedal rod distance is as follows.

When the vehicle is assembled, readjust as necessary.

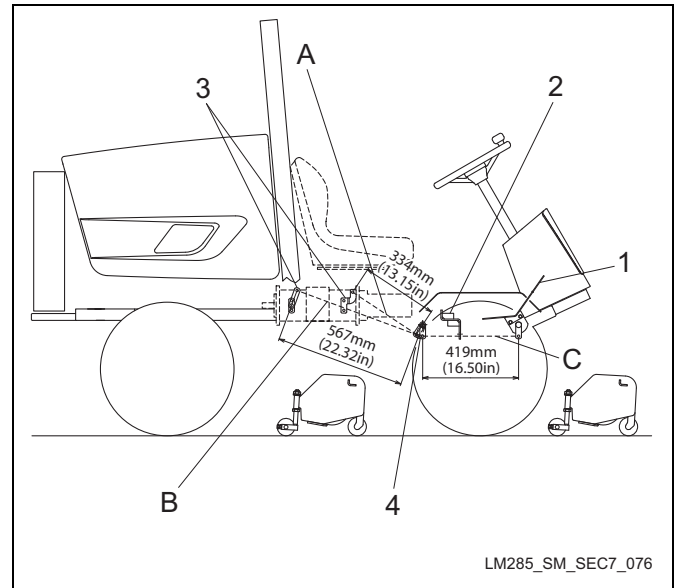

Figure: Main body-4-a

A	Rod for the front wheel
B	Rod for the rear wheel
C	Pedal neutral rod
1	Pedal
2	Neutral bracket
3	Shift lever
4	Idle lever

A: Rod for the front wheel

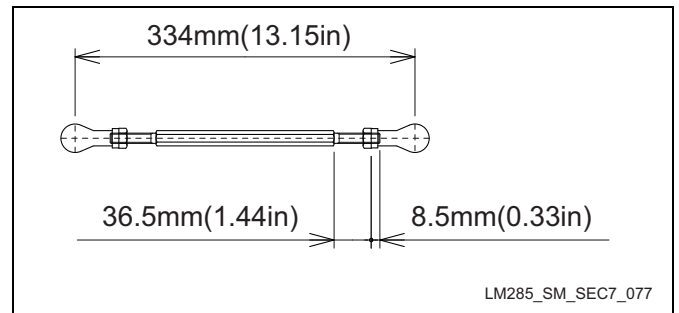

Figure: Main body-5-a

B: Rod for the rear wheel

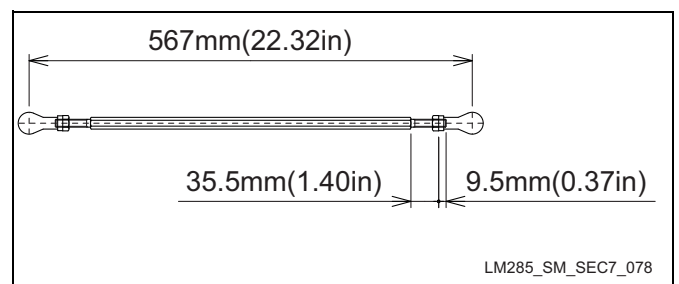

Figure: Main body-6-a

Main body

C: Pedal neutral rod

For the adjustment method, refer to “Adjustment of the traveling pedal rod” (Page 7-3).

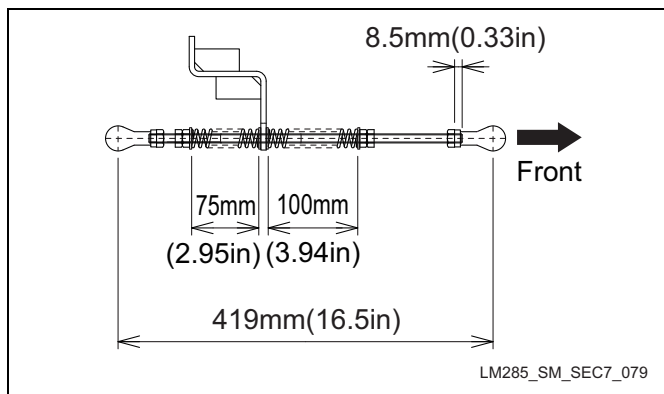
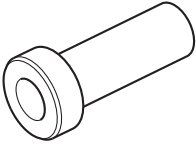
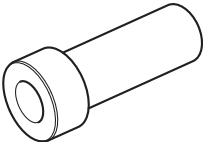
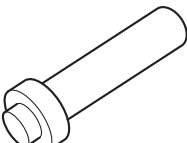
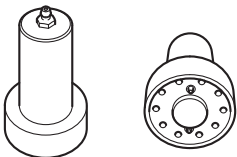

Figure: Main body-7-a

Special tools

<p>6207 Bearing driver</p>  <p>LM285_SM_SEC7_001</p>	<p>K4802000492</p>	<p>For driving and installing the bearing of outer diameter 72mm and inner diameter 35mm</p>
<p>6005 Bearing driver</p>  <p>LM285_SM_SEC7_002</p>	<p>K4802000502</p>	<p>For driving and installing the bearing of outer diameter 47mm and inner diameter 25mm</p>
<p>34 Oil seal driver</p>  <p>LM285_SM_SEC7_003</p>	<p>K4802000522</p>	<p>For driving and installing the oil seal of outer diameter 34mm</p>
<p>TRB Grease injection tool</p>  <p>LM285_SM_SEC7_004</p>	<p>K4802000530</p>	<p>For injecting grease into the tapered roller bearing 30204</p>

Usage

Bearing driver

Use the bearing driver (1) when driving in the bearing etc. precisely.

⚠ Caution

Exercise care in the working to avoid hitting the hand with a hammer and so on.

1. Place the bearing driver (1) on the face of the bearing (2) vertically.

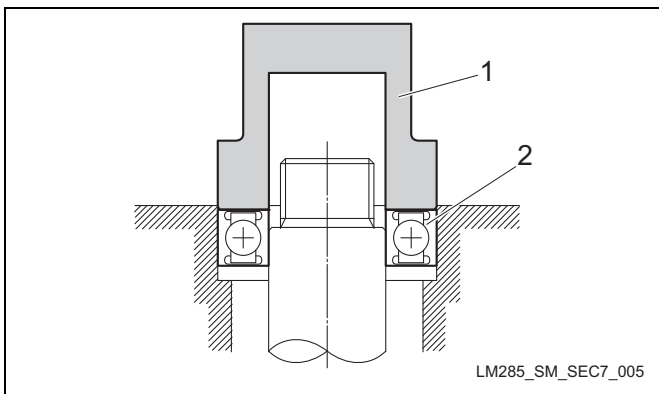

Figure: Main body-8-a

1	Bearing driver
2	Bearing

2. While supporting the bearing driver (1) surely with a hand, drive in the bearing with a hammer (2) and so on.

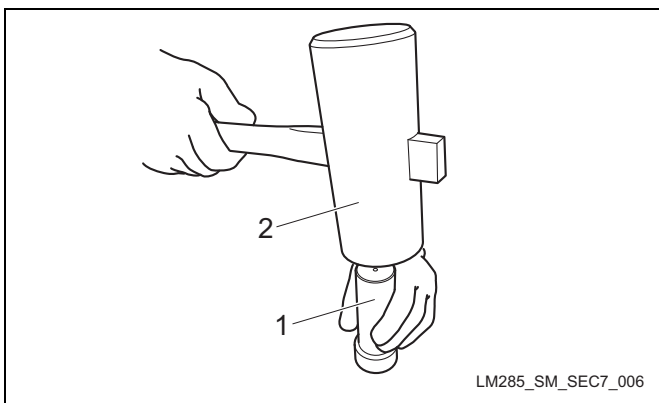

Figure: Main body-9-a

1	Bearing driver
2	Hammer

Oil seal driver

Use the oil seal driver (1) when driving in the oil seal etc. precisely.

⚠ Caution

Exercise care in the working to avoid hitting the hand with a hammer and so on.

1. Place the oil seal driver (1) on the face of the oil seal (2) vertically.

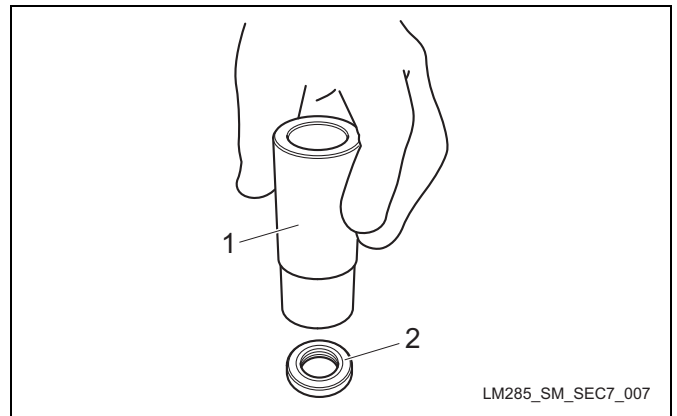

Figure: Main body-10-a

1	Oil seal driver
2	Oil seal

2. While supporting the oil seal driver (1) surely with a hand, drive in the oil seal with a hammer (2) and so on.

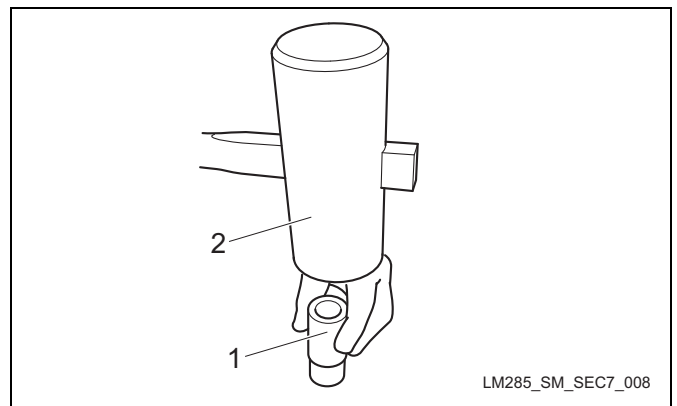

Figure: Main body-11-a

1	Oil seal driver
2	Hammer

Grease injection tool

Use the grease injection tool when injecting grease into the tapered roller bearing 30204.

Main body

1. Set the outer ring (1) and the inner ring (2) of the tapered roller bearing and place them on a flat surface and place the grease injection tool (3) on them vertically.

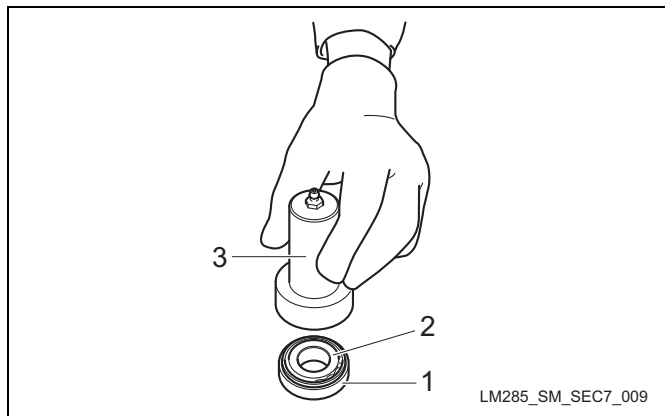

Figure: Main body-12-a

1	Tapered roller bearing outer ring
2	Tapered roller bearing inner ring
3	Grease injection tool

2. Place the grease pump (1) on the grease injection port (3) of the grease injection tool (2) and inject grease 2 to 3 times with the grease pump (1).

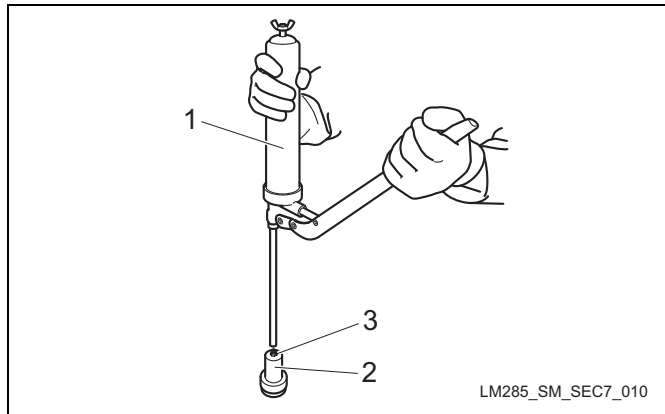

Figure: Main body-13-a

1	Grease pump
2	Grease injection tool
3	Grease injection port

Removal and installation of each section

Wheel

Removal of front wheel

1. Place the jacks at the jack-up points of the right and left front wheel sections surely and raise the main body up to the position where the tires leave the ground. (Refer to "Jack-up point" (Page 3-10))
2. Remove six pieces of the heat-treated bolts (1).

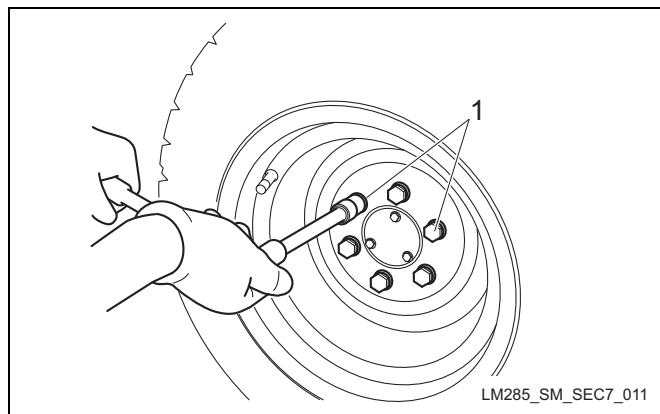

Figure: Main body-14-a

- | | |
|---|-------------------|
| 1 | Heat-treated bolt |
|---|-------------------|
3. Remove the front wheel (2) from the wheel mounting base (1).

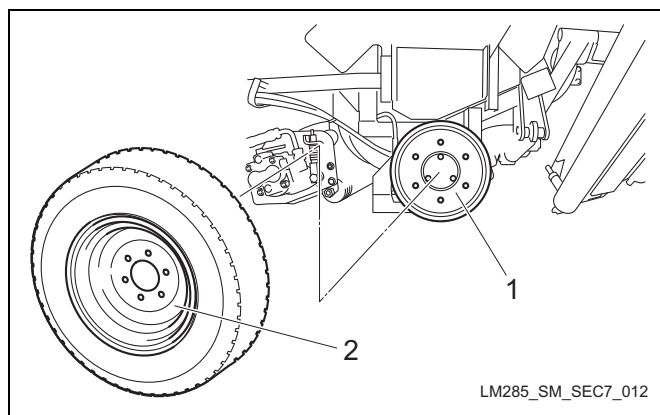

Figure: Main body-15-a

1	Wheel mounting base
2	Front wheel

Installation of front wheel

⚠ Caution

Refer to the tightening torques reference chart. We are not responsible for defects which occurred due to abnormal or overtorque tightening etc.

For installation, reverse the removal procedures.

Removal of rear wheel

1. Place the jacks at the jack-up points of the right and left rear sections surely and raise the main body up to the position where the tires leave the ground. (Refer to “Jack-up point” (Page 3-10))
2. Remove six pieces of the heat-treated bolts (1).

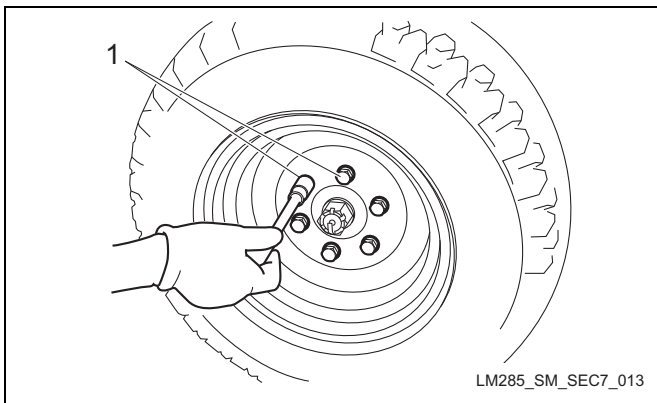

Figure: Main body-16-a

- | | |
|---|-------------------|
| 1 | Heat-treated bolt |
|---|-------------------|

3. Remove the rear wheel (2) from the wheel mounting base (1).

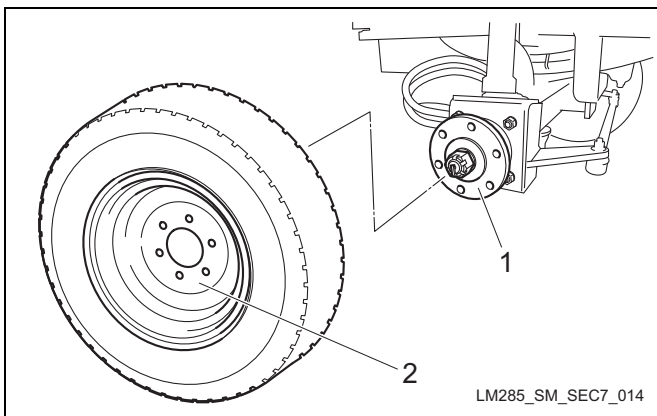

Figure: Main body-17-a

- | | |
|---|---------------------|
| 1 | Wheel mounting base |
| 2 | Rear wheel |

Installation of rear wheel

⚠ Caution

Refer to the tightening torques reference chart. We are not responsible for defects which occurred due to abnormal or overtorque tightening etc.

For installation, reverse the removal procedures.

Brake

Removal of brake drum

1. Remove the front wheel. (Refer to “Removal of front wheel” (Page 7-6))
2. Remove three pieces of the bolts (1) and remove the cover (2).

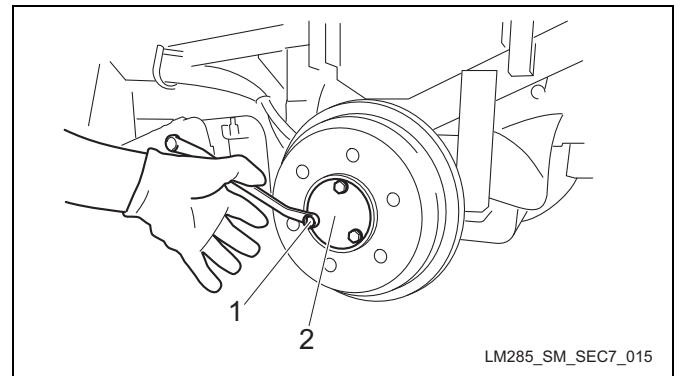

Figure: Main body-18-a

- | | |
|---|-------|
| 1 | Bolt |
| 2 | Cover |

3. Loosen the special nut (1) by about three turns.

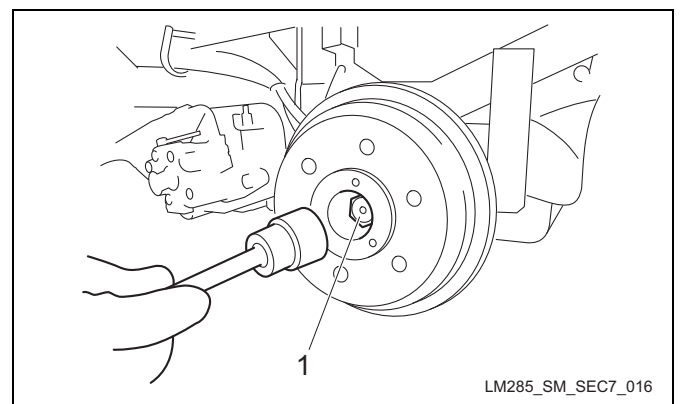

Figure: Main body-19-a

- | | |
|---|-------------|
| 1 | Special nut |
|---|-------------|

Main body

- Release the parking brake and hook and lock the wheel mounting base (1) with the gear puller (2) and tighten the puller to separate the wheel mounting base from the motor shaft.

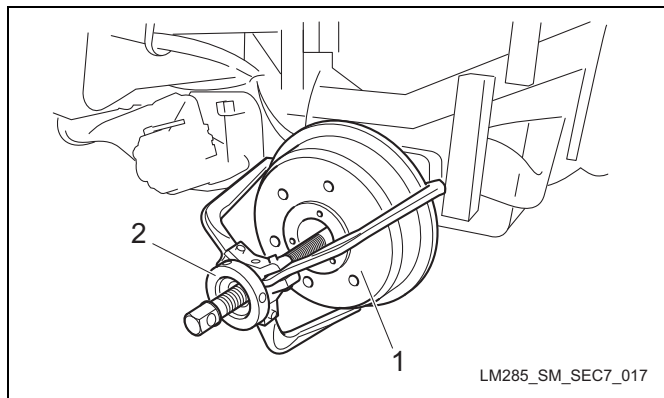

Figure: Main body-20-a

1	Wheel mounting base
2	Gear puller

- Remove the special nut (1), the spring washer (2) and the wheel mounting base (3) from the plate (4).

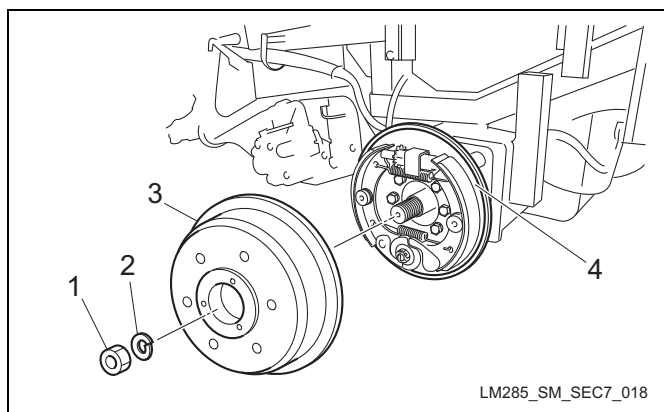

Figure: Main body-21-a

1	Special nut
2	Spring washer
3	Wheel mounting base
4	Plate

Installation of brake drum

⚠ Caution

Apply a middle strength thread locker to the threads of the wheel motor.

⚠ Caution

Refer to the tightening torques reference chart. We are not responsible for defects which occurred due to abnormal or overtorque tightening etc.

For installation, reverse the removal procedures.

Steering

Removal of steering

- Remove the rubber cap (1) and remove the nut (2) and the S washer (3).
- Draw up and remove the steering (4).

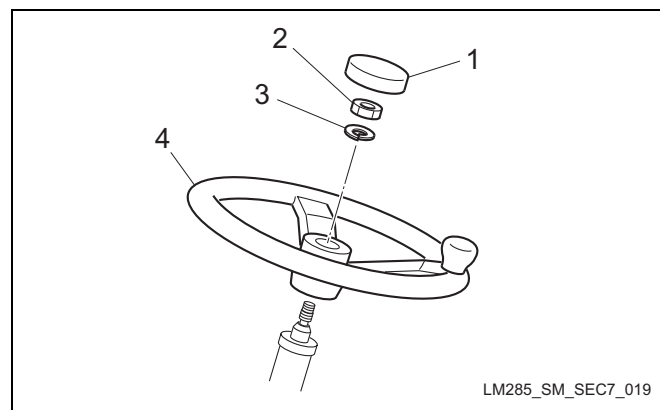

Figure: Main body-22-a

1	Rubber cap
2	Nut
3	S washer
4	Steering

Installation of steering

⚠ Caution

Refer to the tightening torques reference chart. We are not responsible for defects which occurred due to abnormal or overtorque tightening etc.

For installation, reverse the removal procedures.

Removal of steering column

- Remove the front cover. (Refer to "Removal of front cover" (Page 7-17))
- Remove the gauge panel. (Refer to "Removal of gauge panel" (Page 7-19))
- Remove the steering. (Refer to "Removal of steering" (Page 7-8))

- Remove the bolts (1), the S washers (2) and the washers (3) at the six positions and remove the steering column (4).

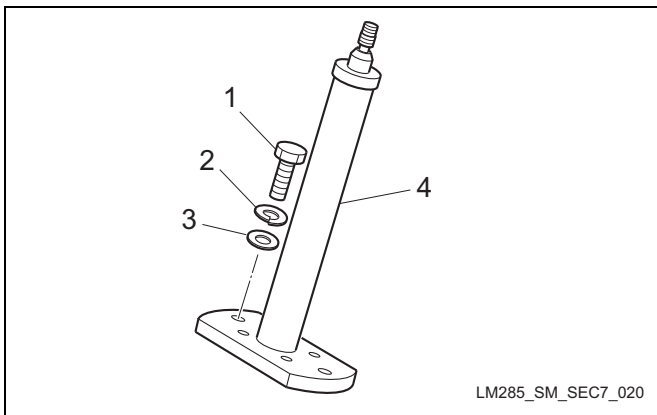

Figure: Main body-23-a

1	Bolt
2	S washer
3	Washer
4	Steering column

Installation of steering column

⚠ Caution

Refer to the tightening torques reference chart. We are not responsible for defects which occurred due to abnormal or overtorque tightening etc.

For installation, reverse the removal procedures.

Axle

Removal of king pin left

⚠ Caution

Exercise care in working due to the heavy king pin.

- Remove the rear wheel. (Refer to “Removal of rear wheel” (Page 7-7))
- Remove the rear wheel motor. (Refer to “Removal of rear wheel motor” (Page 5-61))
- Remove the power steering cylinder. (Refer to “Removal of steering cylinder” (Page 5-57))
- Remove the split pins (3) and the split nuts (4) attached to the tie-rod end (2) of the tie rod (1).

- Support the king pin left (5) with a jack and so on.

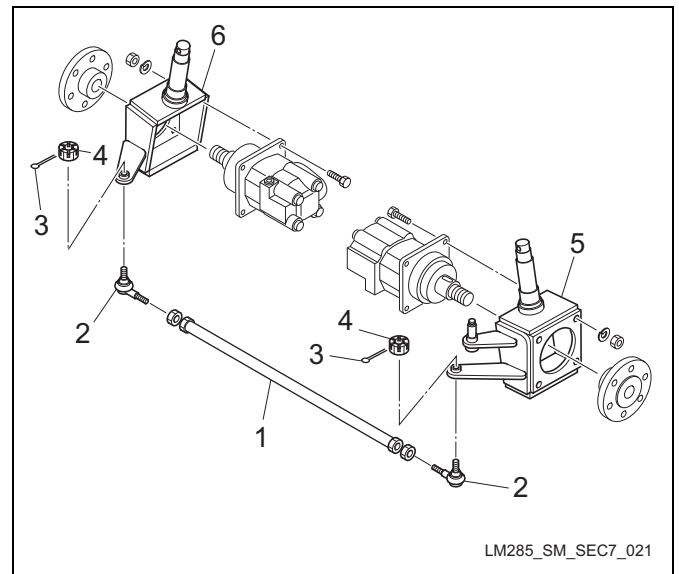

Figure: Main body-24-a

1	Tie rod
2	Tie-rod end
3	Split pin
4	Split nut
5	King pin left
6	King pin right

- Remove the spring pin (1).
- Remove the collar (2) and the cover (3) and remove the king pin left (4) while lowering a jack slowly.
- Remove the thrust bearing (5) and the O ring (6).

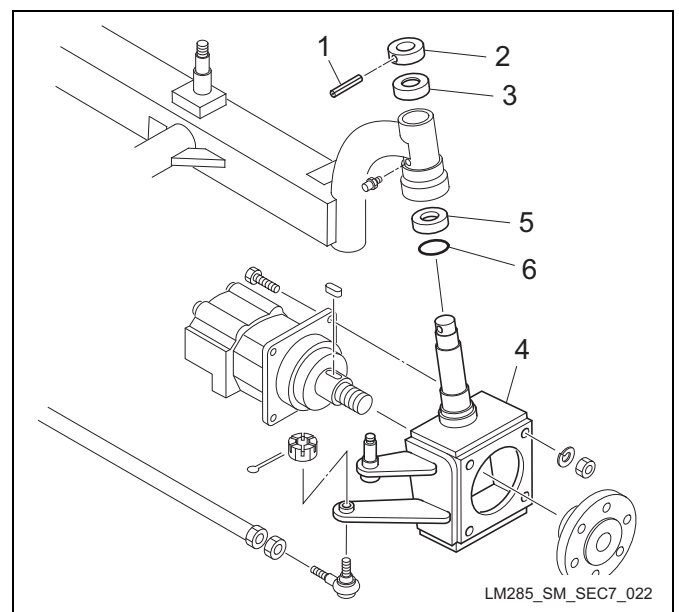

Figure: Main body-25-a

Main body

1	Spring pin
2	Collar
3	Cover
4	King pin left
5	Thrust bearing
6	O ring

Removal of king pin right

Caution

Exercise care in working due to the heavy king pin.

1. Remove the rear wheel. (Refer to “Removal of rear wheel” (Page 7-7))
2. Remove the rear wheel motor. (Refer to “Removal of rear wheel motor” (Page 5-61))
3. Remove the split pins (3) and the split nuts (4) attached to the tie-rod ends (2) of the tie rod (1).
4. Support the king pin right (5) with a jack and so on

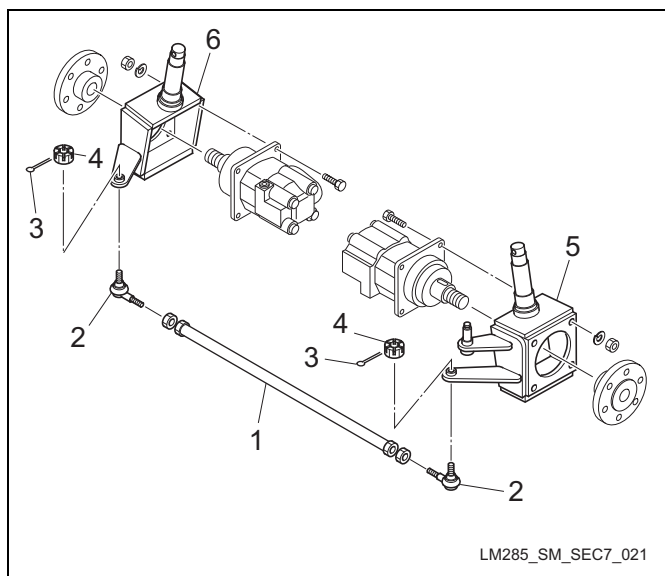

Figure: Main body-26-a

1	Tie rod
2	Tie-rod end
3	Split pin
4	Split nut
5	King pin left
6	King pin right

5. Remove the spring pin (1).
6. Remove the collar (2) and the cover (3) and remove the king pin right (4) while lowering a jack slowly.

7. Remove the thrust bearing (5) and the O ring (6).

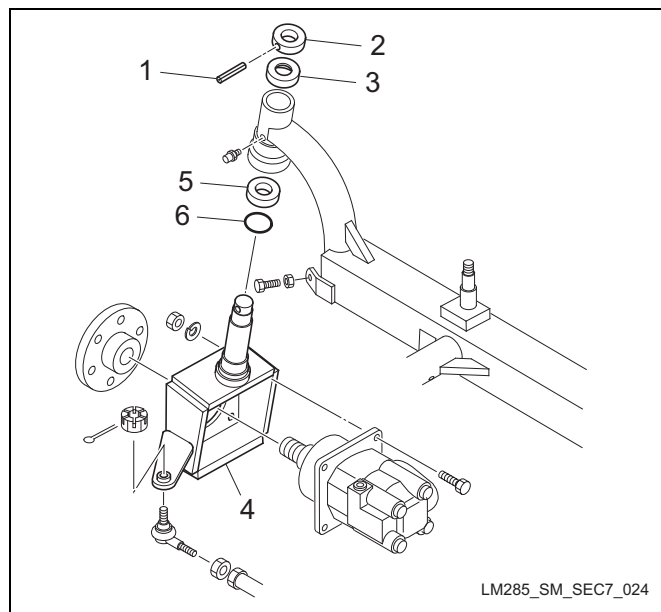

Figure: Main body-27-a

1	Spring pin
2	Collar
3	Cover
4	King pin right
5	Thrust bearing
6	O ring

Installation of king pin left

Caution

Work with supporting the king pin with a jack and so on due to its heavy weight.

1. Apply grease to the shaft of the king pin left (1)
2. Apply grease to the thrust bearing (3) and the O ring (2) and install them to the shaft of the king pin left (1).
3. Insert the king pin left (1) surely to the pivot (4) and install the cover (5) and the collar (6).
4. Position each hole of the shaft of the king pin left (1) and the collar (6) and insert the spring pin (7) with a hammer.

5. Install the steering cylinder. (Refer to “Installation of steering cylinder” (Page 5-57))

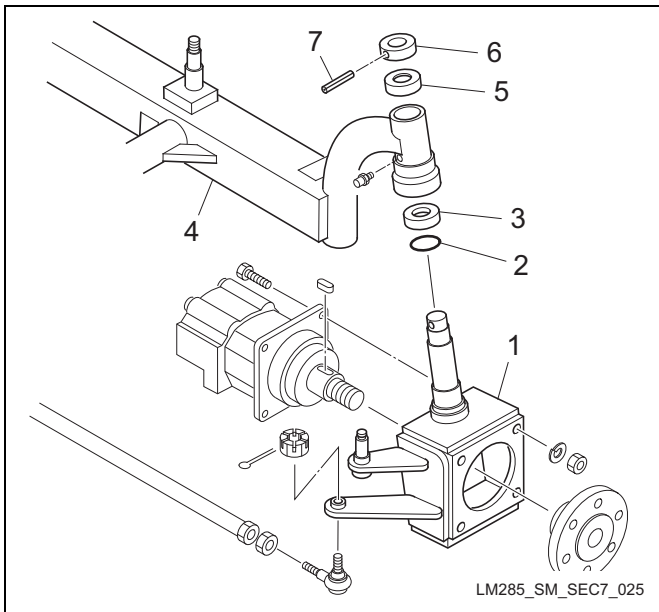

Figure: Main body-28-a

1	King pin left
2	O ring
3	Thrust bearing
4	Pivot
5	Cover
6	Collar
7	Spring pin

Installation of king pin right

⚠ Caution

Work with supporting the king pin with a jack and so on due to its heavy weight.

1. Apply grease to the shaft of the king pin right (1).
2. Apply grease to the thrust bearing (3) and the O ring (2) and install them to the shaft of the king pin right (1).
3. Insert the king pin right (1) surely to the pivot (4) and install the cover (5) and the collar (6).

4. Position each hole of the shaft of the king pin right (1) and the collar (6) and insert the spring pin (7) with a hammer.

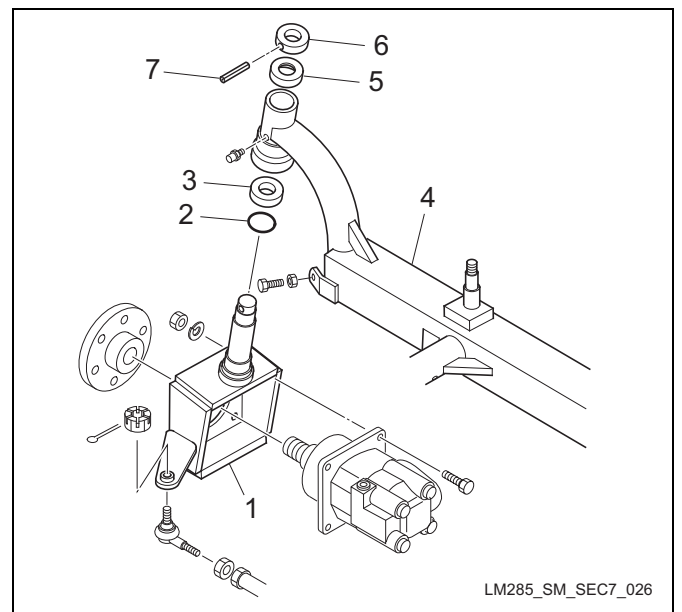

Figure: Main body-29-a

1	King pin right
2	O ring
3	Thrust bearing
4	Pivot
5	Cover
6	Collar
7	Spring pin

Removal of pivot

⚠ Caution

Exercise care in working due to the heavy pivot.

1. Place the jack at the jack-up point of the rear center frame surely and raise the main body up to the position where the tires leave the ground (Refer to “Jack-up point” (Page 3-10))

Main body

- Support at the jack stand points (1) (2) with jack stands surely.

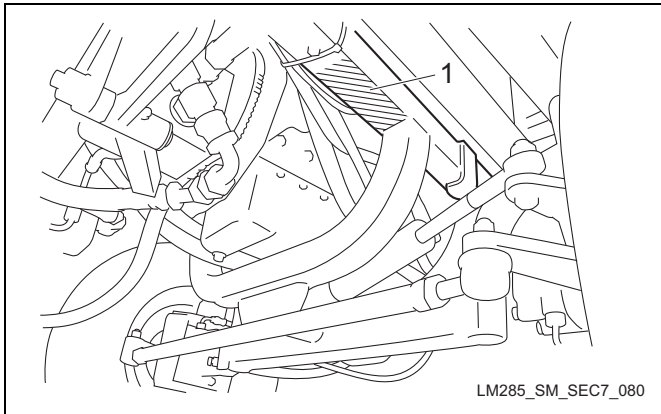

Figure: Main body-30-a

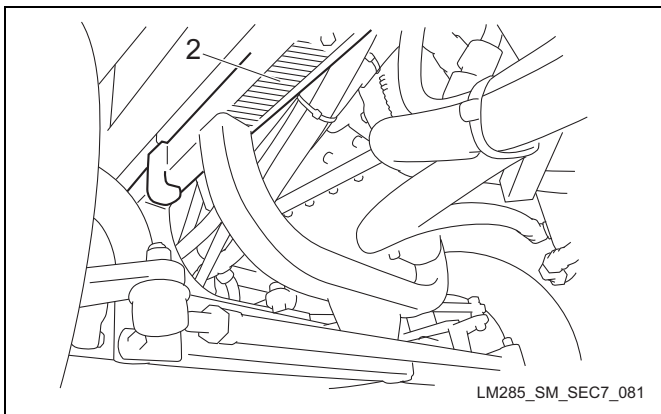

Figure: Main body-31-a

1	Jack stand point 1
2	Jack stand point 2

- Remove the king pin left. (Refer to “Removal of king pin left” (Page 7-9))
- Remove the king pin right. (Refer to “Removal of king pin right” (Page 7-10))
- Support the center of the pivot (1) with the jack and so on.
- Remove the nut (3), the S washer (4) and the washer (5) attached to the pivot pin (2).
- Draw out the pivot pin (2).

- Remove the pivot (1).

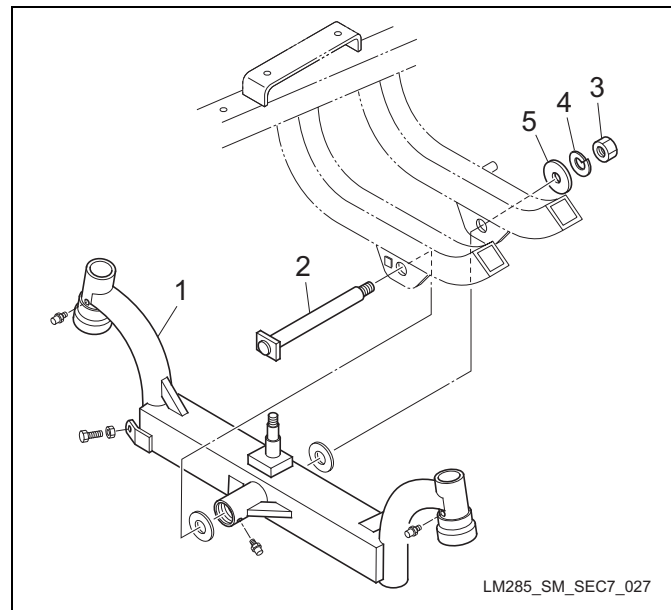

Figure: Main body-32-a

1	Pivot
2	Pivot pin
3	Nut
4	S washer
5	Washer

Installation of pivot

Caution

Exercise care in working due to the heavy pivot

Caution

Refer to the tightening torques reference chart. We are not responsible for defects which occurred due to abnormal or overtorque tightening etc.

- Apply grease to the pivot pin (2) and the pivot pin insertion site of the pivot (1).
- Put the pivot (1) on the jack and raise it while adjusting the position to the hole of the frame section.

3. Install the washer (5), the S washer (4) and the nut (3).

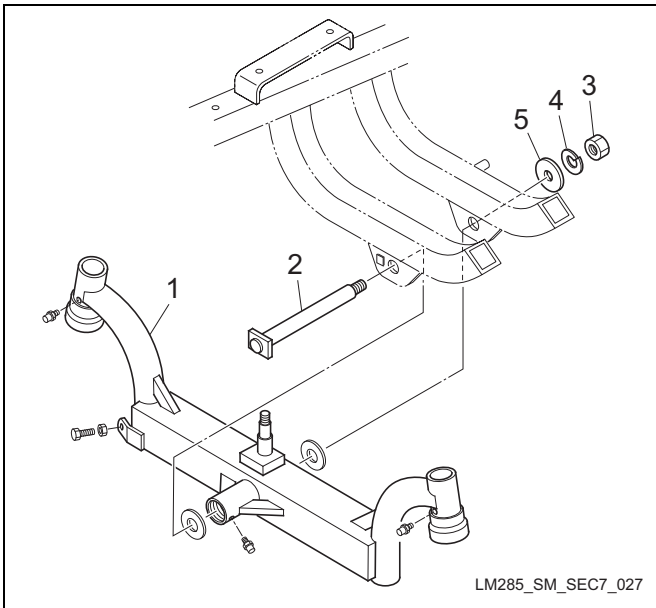
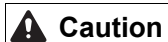

Figure: Main body-33-a

1	Pivot
2	Pivot pin
3	Nut
4	S washer
5	Washer

Seat

Removal of seat



Caution

Work in a twosome due to the heavy seat.

1. Pull the slide lever (1) and slide the seat (2) to the forward end

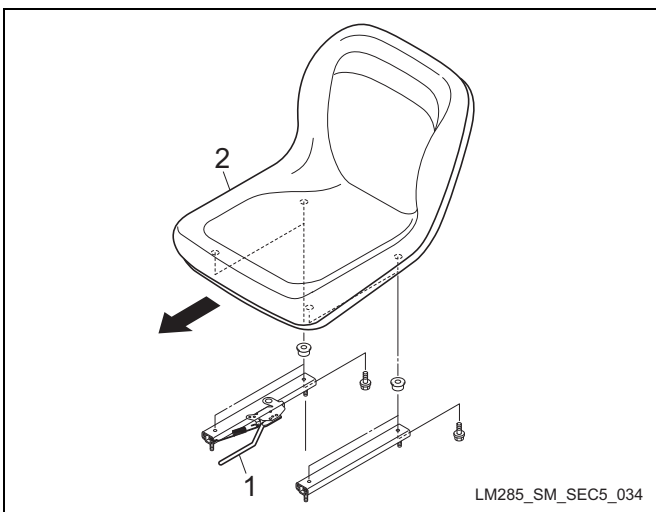

Figure: Main body-34-a

1	Slide lever
2	Seat

2. Remove the bolts (2), S washers (3) and washers (4) behind the seat, which fasten the cover under seat (1).

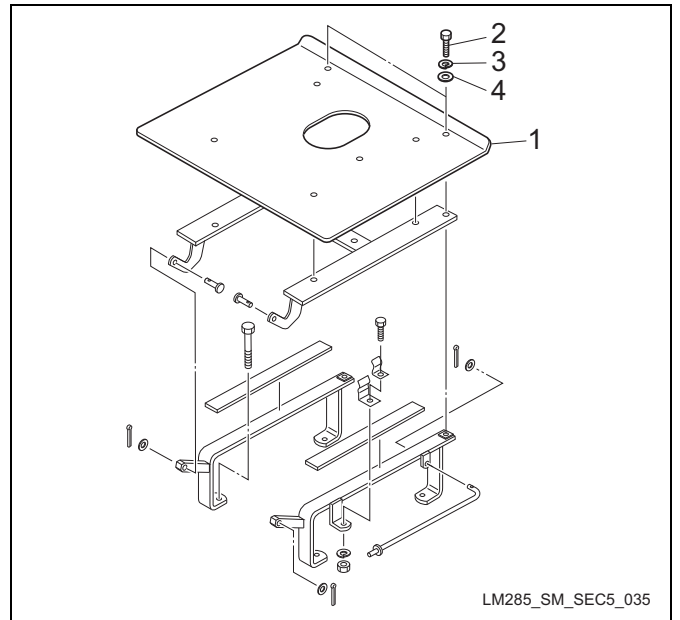

Figure: Main body-35-a

1	Cover under seat
2	Bolt
3	S washer
4	Washer

3. Lift up the seat (1).
4. Insert and fix the stand (2) to the seat mounting plate (3).

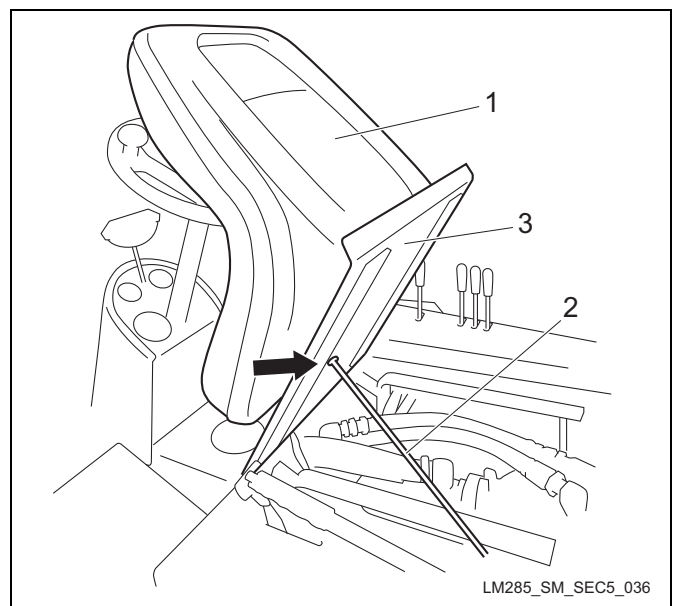

Figure: Main body-36-a

Main body

1	Seat
2	Stand
3	Seat mounting plate

5. Remove the terminal for safety switch (1).

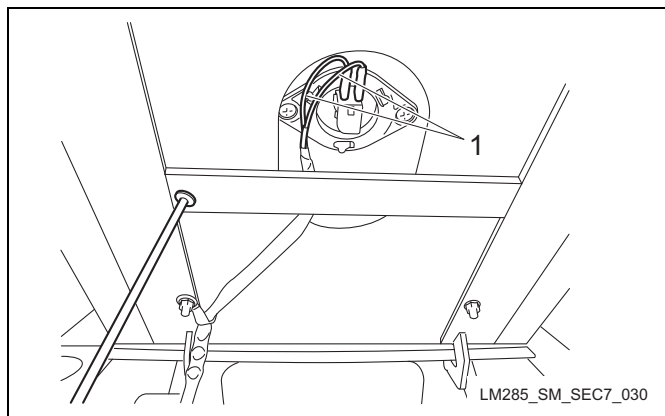

Figure: Main body-37-a

1	Stand
2	Terminal for safety switch

6. Remove the nuts (2) and the S washers (3)
7. Remove the seat (1).

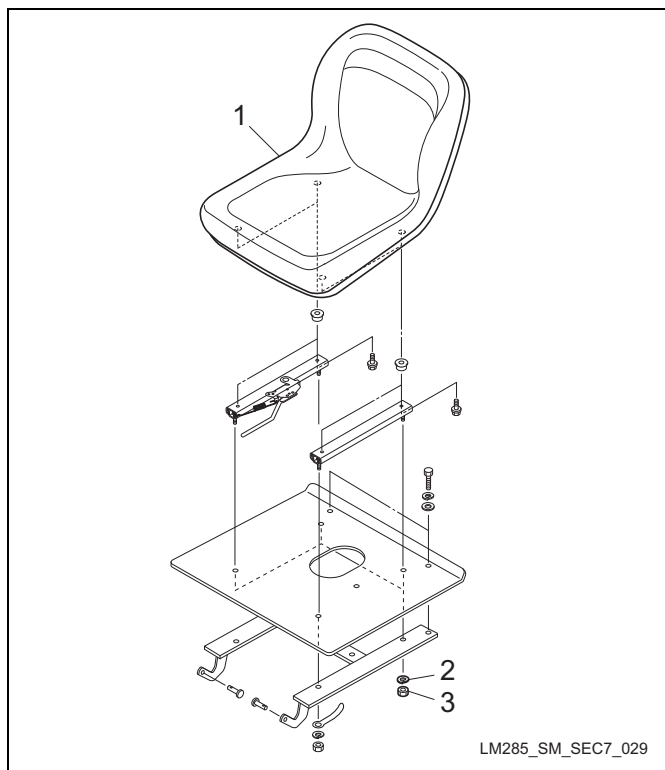

Figure: Main body-38-a

1	Seat
2	S washer
3	Nut

Installation of seat

⚠ Caution

Refer to the tightening torques reference chart. We are not responsible for defects which occurred due to abnormal or overtorque tightening etc.

For installation, reverse the removal procedures.

Removal of cover under seat

1. Remove the seat. (Refer to “Removal of seat” (Page 7-13))
2. Remove the cover under seat (1).
3. Remove the split pins (2) and the washers (3) and draw out the pins (4).
4. Remove the seat mounting plate (5).

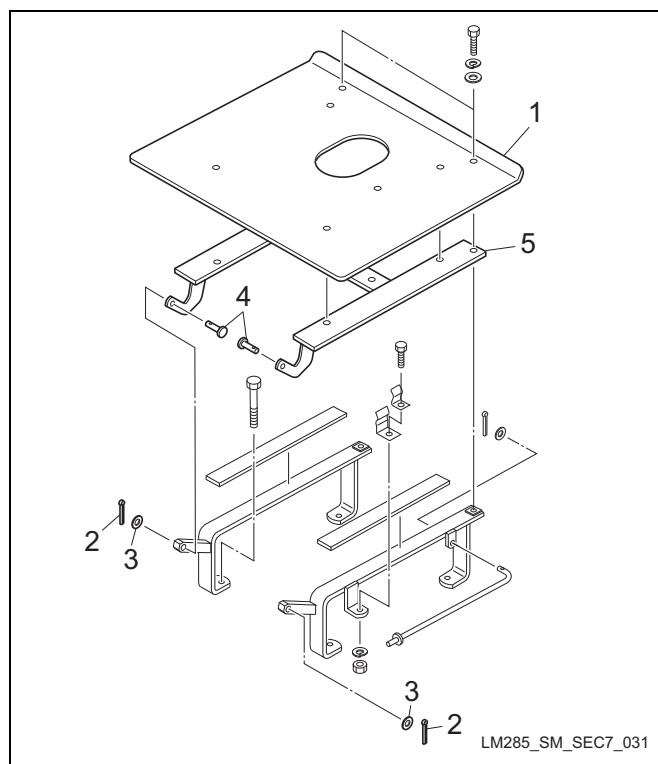

Figure: Main body-39-a

1	Cover under seat
2	Split pin
3	Washer
4	Pin
5	Seat mounting plate

5. Remove the bolts (1), the washers (2), the S washers (3) and the nuts (4).

6. Remove the seat mount fittings (5).

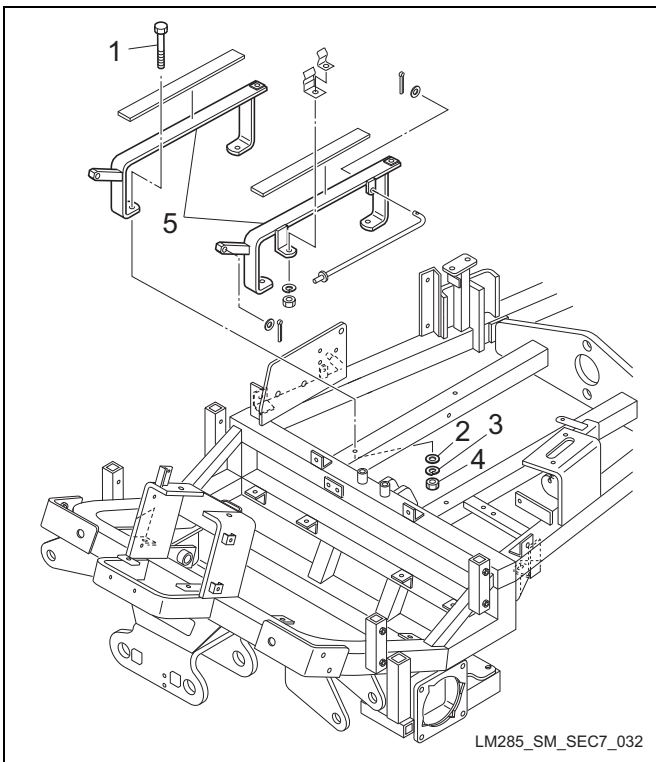

Figure: Main body-40-a

1	Bolt
2	Washer
3	S washer
4	Nut
5	Seat mount fitting

Installation of cover under seat

Caution

Refer to the tightening torques reference chart. We are not responsible for defects which occurred due to abnormal or overtorque tightening etc.

For installation, reverse the removal procedures.

Fuel tank

Removal of fuel tank

Caution

Exercise care in working due to the heavy fuel tank.

1. Open the rear cover. (Refer to “Removal of rear cover” (Page 7-18))

2. Loosen the clip (2) of the fuel hose (1) and remove the fuel hose (1) and drain all the fuel.

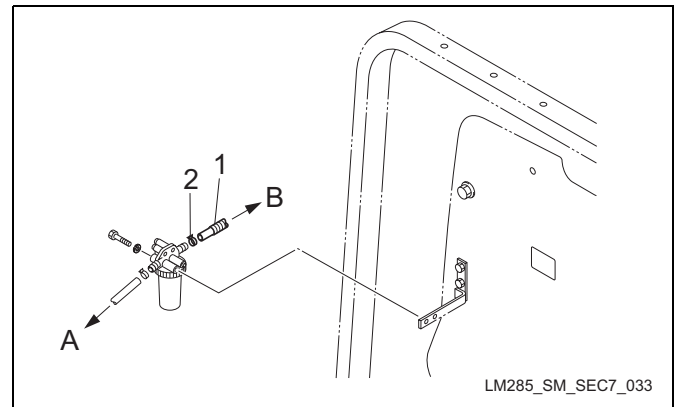

Figure: Main body-41-a

A	To fuel transport pump
B	To fuel tank
1	Fuel hose
2	Clip

3. Loosen the clip (2) of the return hose (1) and remove the return hose (1).
4. Remove the connector wiring (4) of the fuel unit (3).
5. Loosen the clips (5) of the connector wiring (4) and remove the wiring.

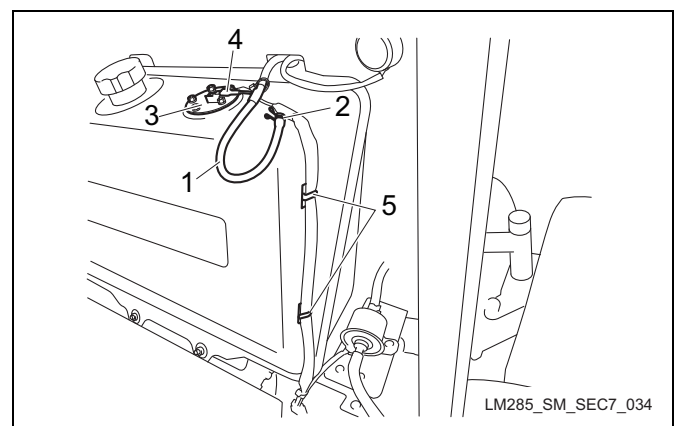

Figure: Main body-42-a

1	Return hose
2	Clip
3	Fuel unit
4	Connector wiring
5	Clip

6. Remove the nuts (1), the S washers (2) and the washers (3).

Main body

- Remove the fuel tank (4).

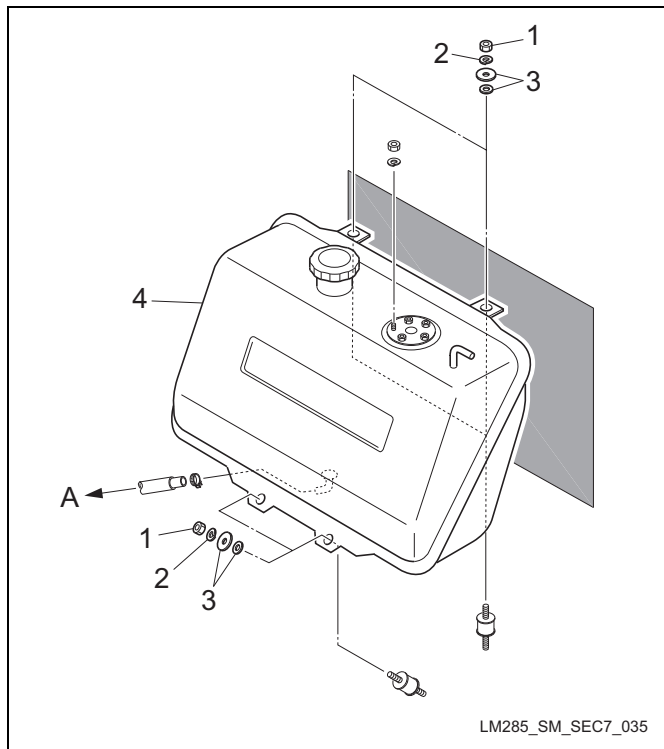

Figure: Main body-43-a

A	To fuel filter
1	Nut
2	S washer
3	Washer
4	Fuel tank

Installation of fuel tank

⚠ Caution

Refer to the tightening torques reference chart. We are not responsible for defects which occurred due to abnormal or overtorque tightening etc.

For installation, reverse the removal procedures.

Lift arm

Removal of mower lift arm

■ #1 mower

⚠ Caution

In the case of working by one person, exercise care in working due to the heavy lift arm.

- Remove the mower unit. (Refer to “Removal of mower unit” (Page 8-4))

- Remove the split pin (2) and the washer (3) of the cylinder flat head pin (1).
- While supporting the lift arm (4) with a hand, remove the split pins (6) and the washers (7) of the lift arm pin (5).

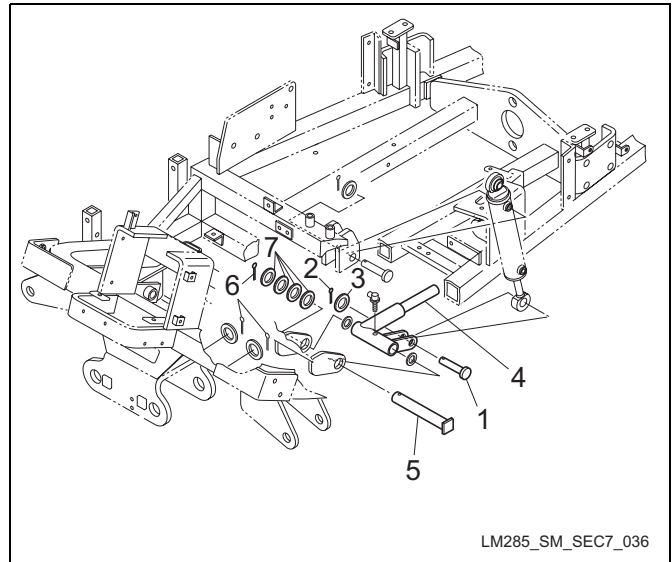

Figure: Main body-44-a

1	Cylinder flat head pin
2	Split pin
3	Washer
4	Lift arm
5	Lift arm pin
6	Split pin
7	Washer

■ #2, #3 mower

⚠ Caution

In the case of working by one person, exercise care in working due to the heavy lift arm.

- Remove the mower unit. (Refer to “Removal of mower unit” (Page 8-4))
- Remove the split pin (2) and the washer (3) of the cylinder flat head pin (1).

3. While supporting the lift arm (4) with a hand, remove the split pin (6) and the washer (7) of the lift arm pin (5).

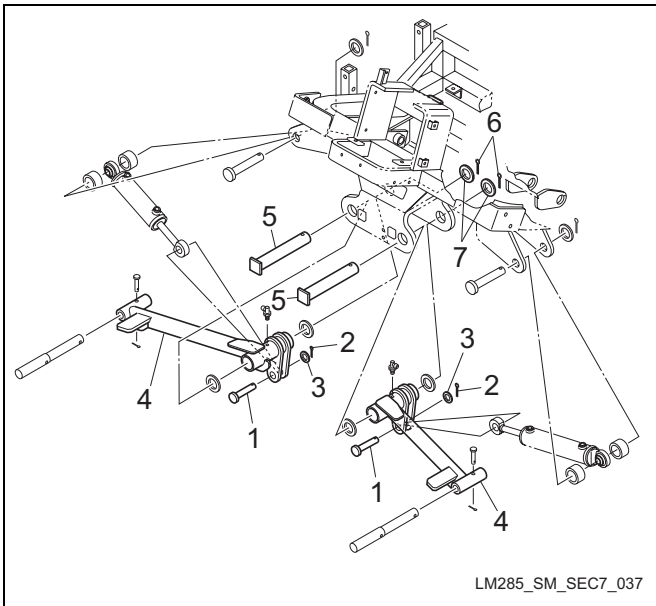

Figure: Main body-45-a

1	Cylinder flat head pin
2	Split pin
3	Washer
4	Lift arm
5	Lift arm pin
6	Split pin
7	Washer

■ #4, #5 mower

⚠ Caution

In the case of working by one person, exercise care in working due to the heavy lift arm.

1. Remove the mower unit. (Refer to "Removal of mower unit" (Page 8-4))
2. Remove the bolt (3), the washer (4) and the nut (5) of the chain (2) attached to the rear lift arm (1).
3. Remove the split pins (7) and the washers (8) of the cylinder flat head pins (6).

4. While supporting the lift arm (1) with a hand, remove the split pin (7) and the washer (8) of the lift arm pin (9).

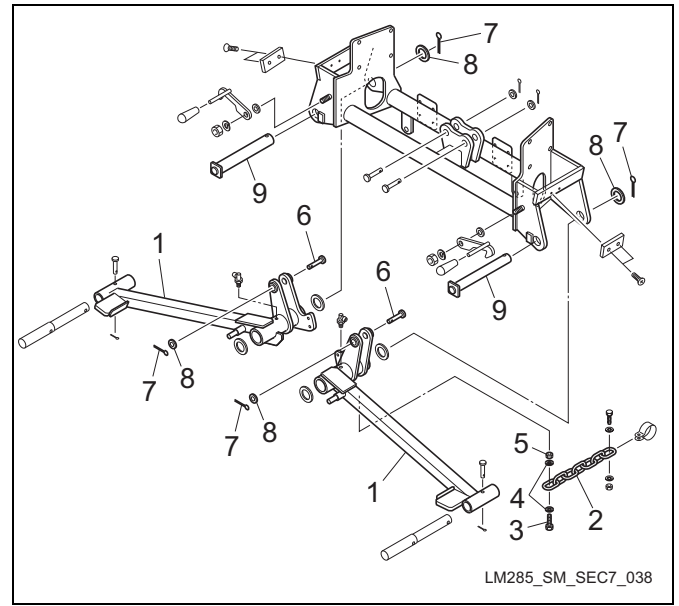

Figure: Main body-46-a

1	Rear lift arm
2	Chain
3	Bolt
4	Washer
5	Nut
6	Cylinder flat head pin
7	Split pin
8	Washer
9	Lift arm pin

Installation of mower lift arm

⚠ Caution

Refer to the tightening torques reference chart. We are not responsible for defects which occurred due to abnormal or overtorque tightening etc.

For installation, reverse the removal procedures.

Cover

Removal of front cover

1. Remove the bolts (2), the S washers (3), the washers (4) and the rubber washers (5) fastening the front cover (1).
2. Remove the bolts (7) and the S washers (8) fastening the angle gauge mount plate (6).

Main body

3. Remove the front cover (1).

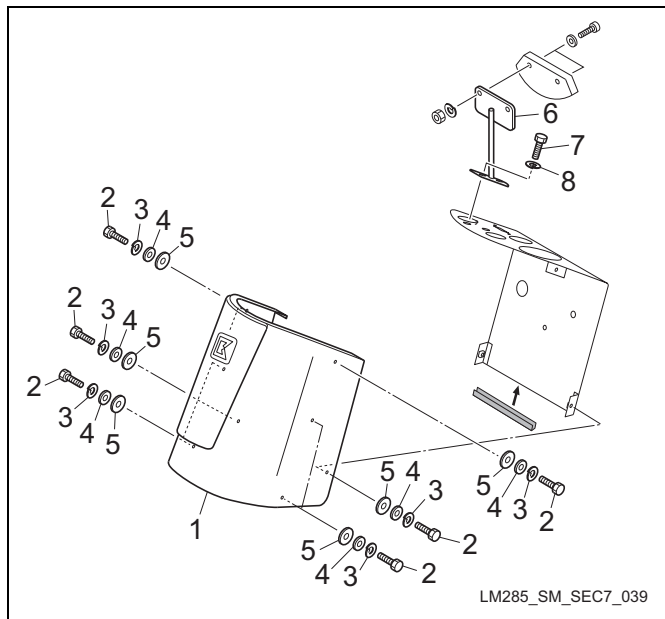

Figure: Main body-47-a

1	Front cover
2	Bolt
3	S washer
4	Washer
5	Rubber washer
6	Angle gauge mount plate
7	Bolt
8	S washer

Installation of front cover

⚠ Caution

Refer to the tightening torques reference chart. We are not responsible for defects which occurred due to abnormal or overtorque tightening etc.

For installation, reverse the removal procedures.

Removal of rear cover

⚠ Caution

In the case of working by one person, exercise care in working due to the heavy bonnet.

Release the rubber catch (1) and lift up the bonnet (2).

1. Hook the bonnet support (3) on the hanger (4) inside the bonnet (2) and confirm the bonnet will not close without a supporting hand.

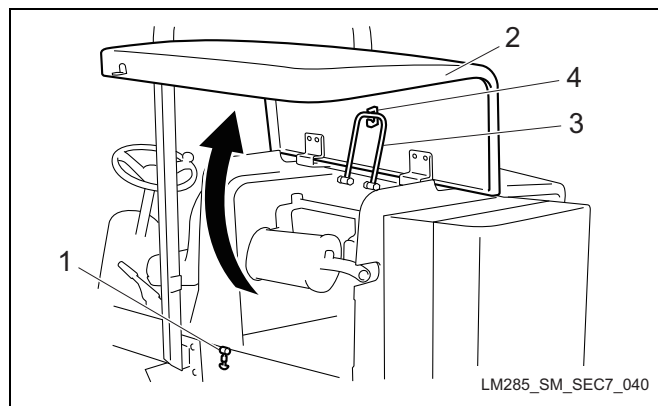

Figure: Main body-48-a

1	Rubber catch
2	Bonnet
3	Bonnet support
4	Hanger

2. Remove the nuts (1), the S washers (2) and the washers (3) and remove the bonnet.

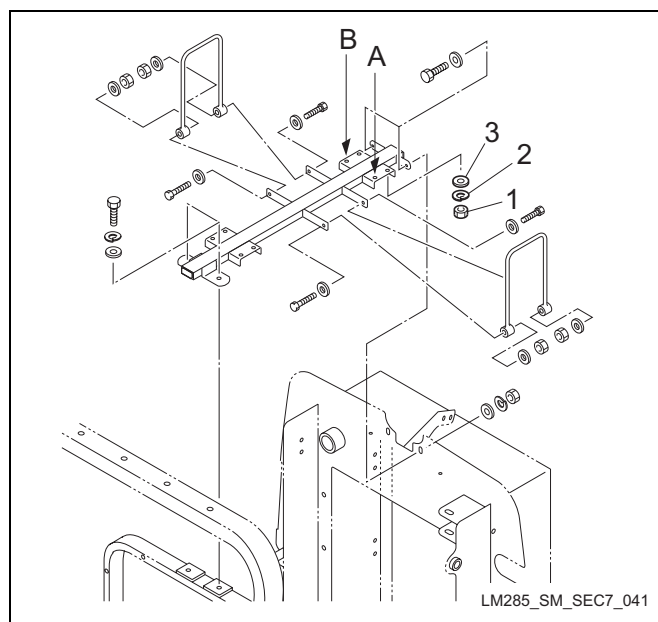

Figure: Main body-49-a

1	Nut
2	S washer
3	Washer

- Loosen the bolt (1) and remove the nut (4), the S washer (3) and the washer (2) together with the rubber catch (5).

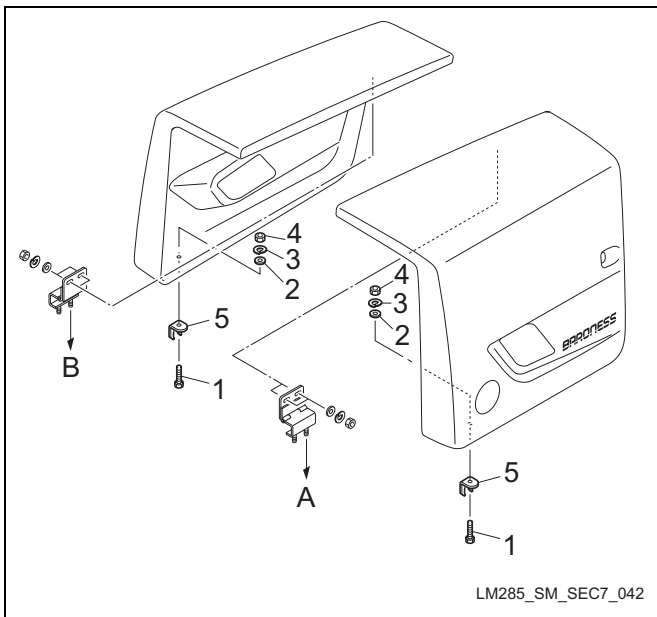

Figure: Main body-50-a

1	Bolt
2	Washer
3	S washer
4	Nut
5	Rubber catch

Installation of rear cover

⚠ Caution

Refer to the tightening torques reference chart. We are not responsible for defects which occurred due to abnormal or overtorque tightening etc.

For installation, reverse the removal procedures.

Removal of gauge panel

- Remove the front cover. (Refer to “Removal of front cover” (Page 7-17))
- Remove the steering. (Refer to “Removal of steering” (Page 7-8))

- Unplug all the connectors (1).

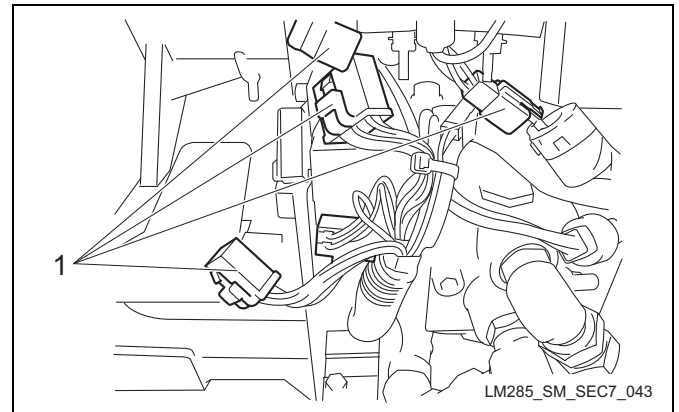

Figure: Main body-51-a

1	Connector
---	-----------

- Remove the rubber cover (1) of the light switch lever.
- Remove the light switch lever (2).
- Remove the gauge panel bolt (3) and pull up and remove the gauge panel (4).

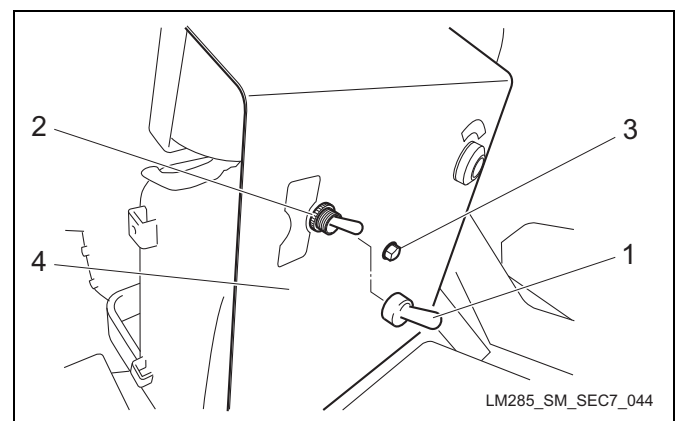

Figure: Main body-52-a

Installation of gauge panel

⚠ Caution

Refer to the tightening torques reference chart. We are not responsible for defects which occurred due to abnormal or overtorque tightening etc.

For installation, reverse the removal procedures.

Main body

Removal of center cover

1. Remove the bolts (2) of the center cover rear (1) and remove the center cover rear (1).

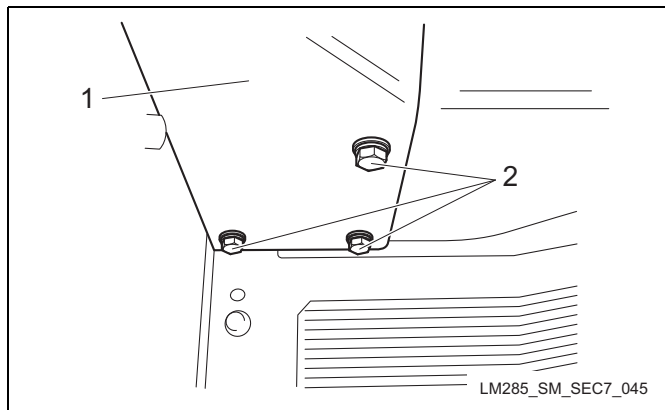

Figure: Main body-53-a

1	Center cover rear
2	Bolt

2. Remove the bolts (2) of the center cover front (1) and remove the center cover front (1).

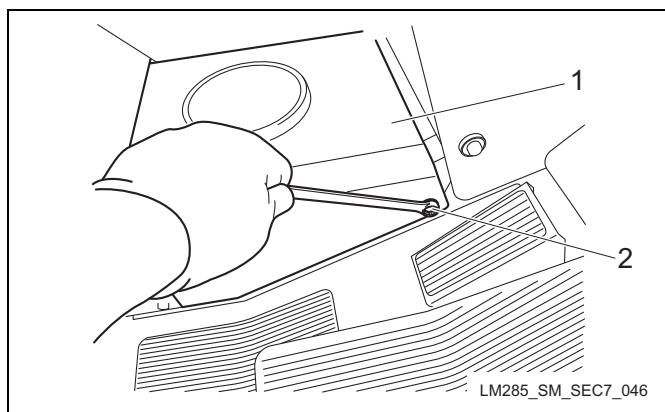
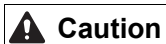

Figure: Main body-54-a

1	Center cover front
2	Bolt

Installation of center cover



Caution

Refer to the tightening torques reference chart. We are not responsible for defects which occurred due to abnormal or overtorque tightening etc.

For installation, reverse the removal procedures.

Removal of step left

1. Remove the center cover. (Refer to “Removal of center cover” (Page 7-20))

2. Remove the bolts (1), the S washers (2) and the washers (3) and remove the step left (4).

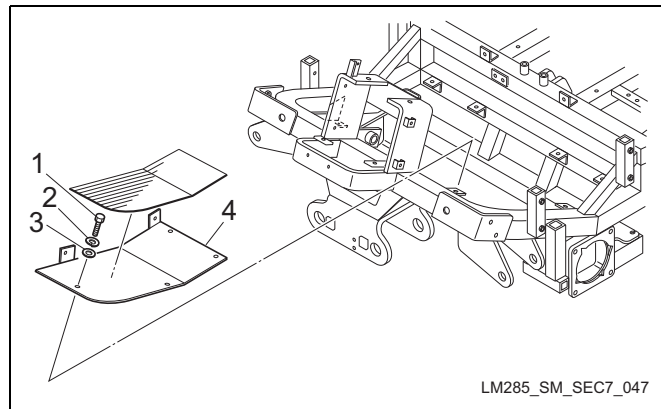

Figure: Main body-55-a

1	Bolt
2	S washer
3	Washer
4	Step left

Removal of step right

1. Remove the center cover. (Refer to “Removal of center cover” (Page 7-20))
2. While depressing the rear side of the pedal (1), remove the bolt (2) of the front side.

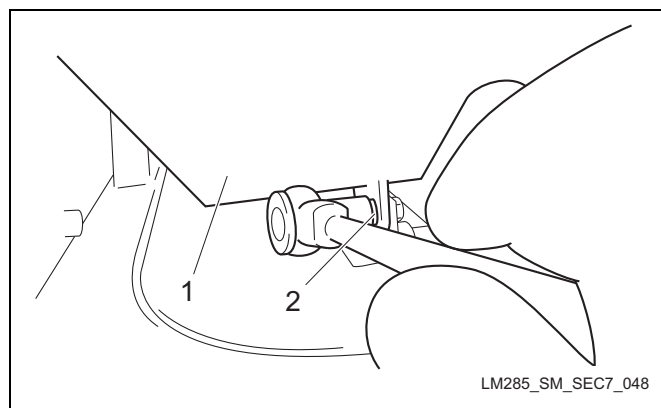

Figure: Main body-56-a

1	Pedal
2	Bolt

- While pulling up the front side of the pedal (1) by hand, remove the bolt (2) of the rear side and remove the pedal (1).

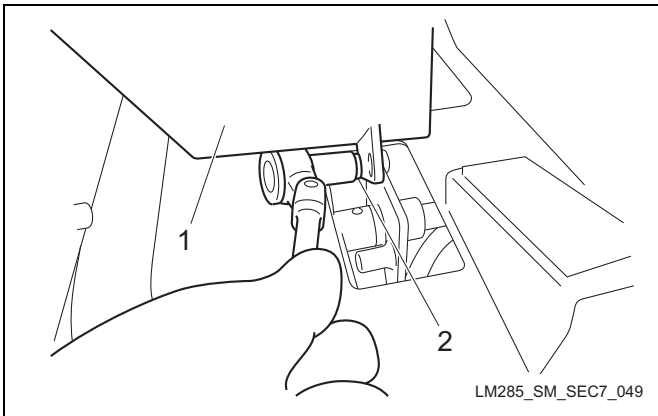

Figure: Main body-57-a

1	Pedal
2	Bolt

- Remove the bolts (2) in four places of the step right (1) and remove the step right (1).

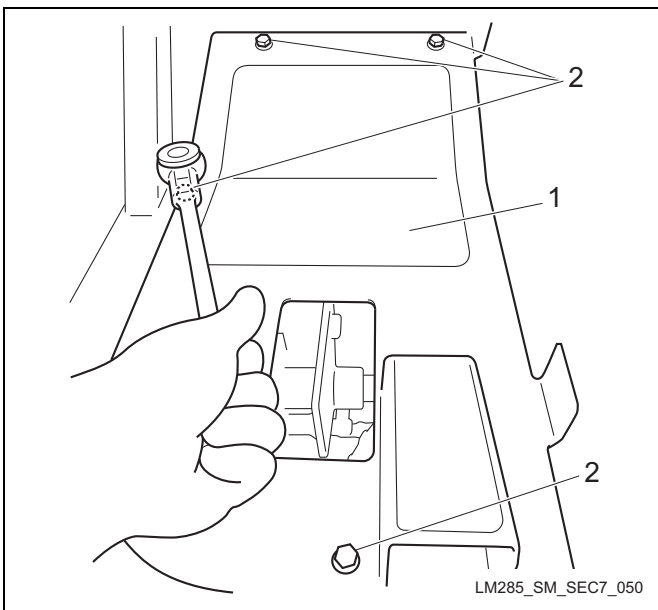

Figure: Main body-58-a

1	Step right
2	Bolt

Installation of step left

⚠ Caution

Refer to the tightening torques reference chart. We are not responsible for defects which occurred due to abnormal or overtorque tightening etc.

For installation, reverse the removal procedures.

Installation of step right

⚠ Caution

Refer to the tightening torques reference chart. We are not responsible for defects which occurred due to abnormal or overtorque tightening etc.

For installation, reverse the removal procedures.

Removal of wheel cover left

- Remove the bolts (1), the S washers (2) and the washers (3) in four places and remove the wheel cover left (4).

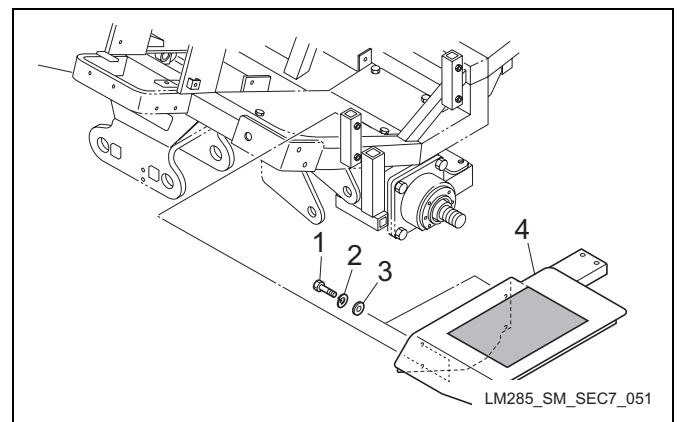

Figure: Main body-59-a

1	Bolt
2	S washer
3	Washer
4	Wheel cover left

Installation of wheel cover left

⚠ Caution

Refer to the tightening torques reference chart. We are not responsible for defects which occurred due to abnormal or overtorque tightening etc.

For installation, reverse the removal procedures.

Main body

Removal of wheel cover right

1. Remove the bolts (1), the S washers (2) and the washers (3) in four places and remove the wheel cover right (4).

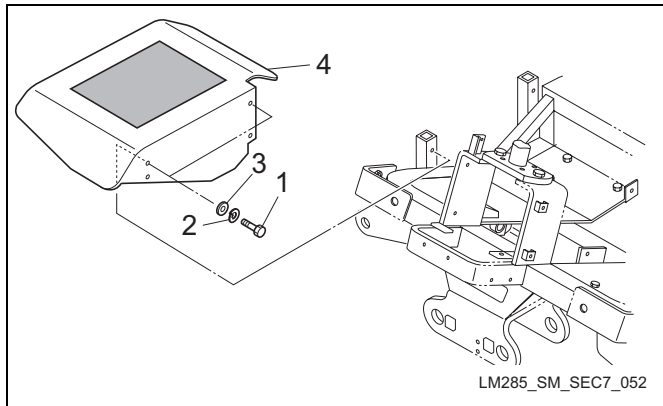

Figure: Main body-60-a

1	Bolt
2	S washer
3	Washer
4	Wheel cover right

Installation of wheel cover right

Caution

Refer to the tightening torques reference chart. We are not responsible for defects which occurred due to abnormal or overtorque tightening etc.

For installation, reverse the removal procedures.

Lever damper

Removal of lever damper

1. Remove the center cover. (Refer to “Removal of center cover” (Page 7-20))
2. Remove the step right. (Refer to “Removal of step right” (Page 7-20))

3. Remove the bolt (2) and the nuts (3) of the lever damper (1).

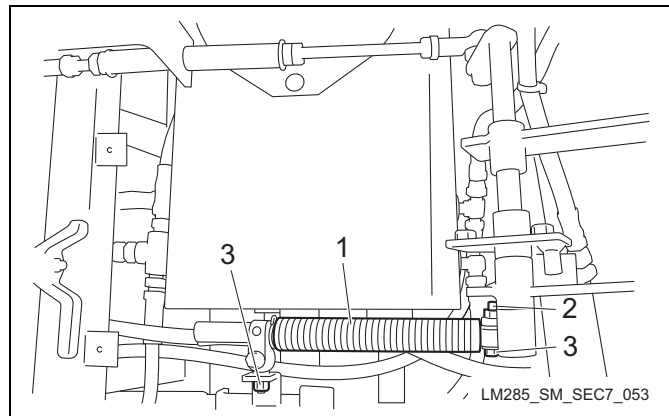

Figure: Main body-61-a

1	Lever damper
2	Bolt
3	Nut

Installation of lever damper

Caution

Refer to the tightening torques reference chart. We are not responsible for defects which occurred due to abnormal or overtorque tightening etc.

For installation, reverse the removal procedures.

Inspection and repair of each section

Tire

Inspection of tire

Caution

Check “Main body: Specifications” for tire pressure. Do not pump up a tire more than the specified pressure.

A worn tire tread may hamper the primary operation of this equipment or result in bursting or slippage of the tire. Check the tires for any abnormality as described below.

1. Tire pressure
2. Crack, damage
3. Abnormal abrasion

Brake

A worn brake shoe will increase the amount of brake pedal depression, and may cause the pedal to touch the floor or result in uneven braking. Inspect the brake accordingly.

Adjust the brake shoe clearance to be even on both sides. A brake shoe is gradually worn down like an eraser as the brake is applied. Check the remaining shoe amount upon inspection and replace as needed.

Disassembly and assembly of brake

A brake shoe (1) can be replaced with this equipment fitted.

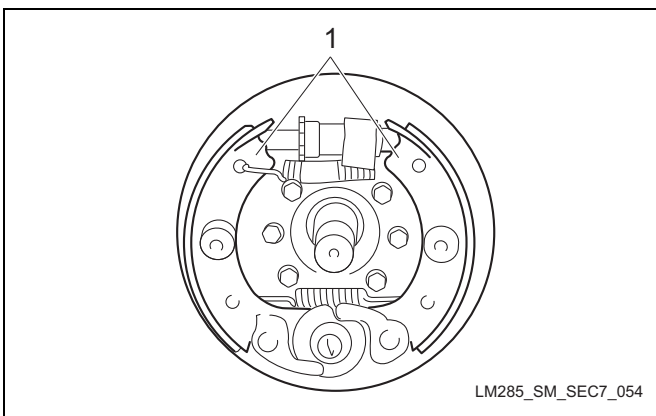

Figure: Main body-62-a

1	Shoe
---	------

1. Remove the springs (1) on both sides. They are different in size.

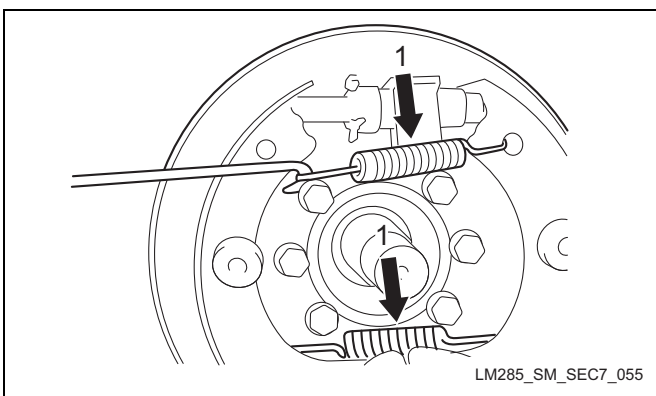

Figure: Main body-63-a

1	Spring
---	--------

2. Remove the shoe support (1).

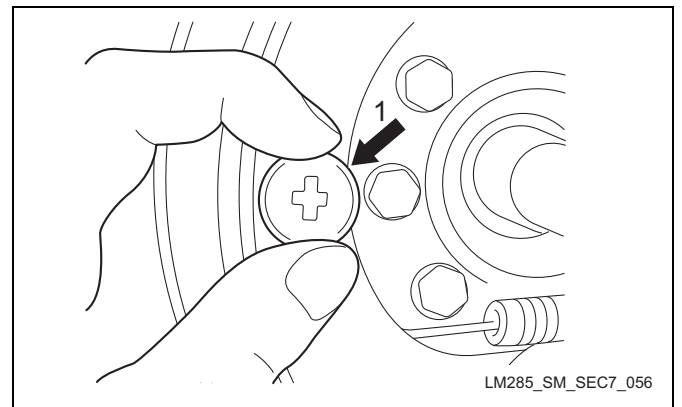

Figure: Main body-64-a

1	shoe support
---	--------------

3. Turn the spring support (1) 90° while pushing it in.

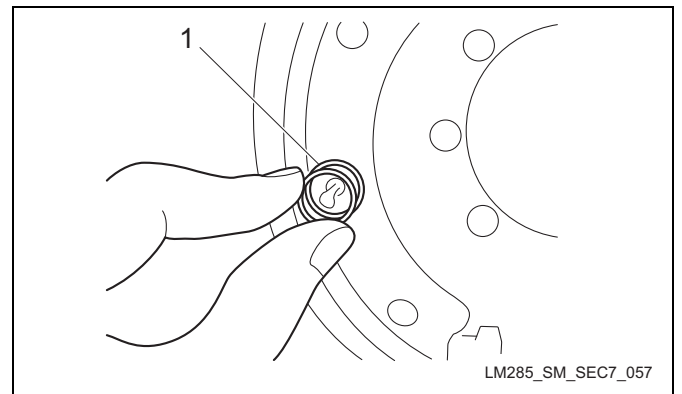

Figure: Main body-65-a

1	Spring support
---	----------------

4. Remove the shoe (1) and the adjuster screw (2).

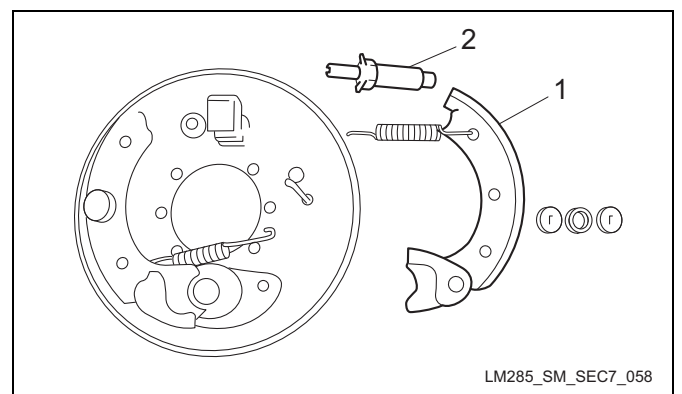

Figure: Main body-66-a

1	Shoe
2	Adjuster screw

Main body

- When assembling, apply grease to the sliding part. Use grease that is exclusively for brakes and never apply onto the shoe friction surface. If it adhered on the surface, remove it with brake cleaner etc.

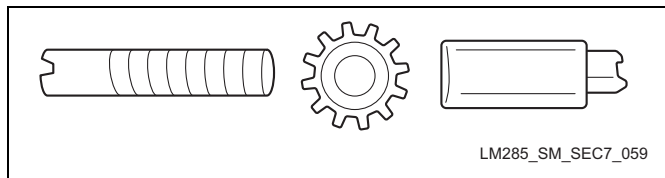

Figure: Main body-67-a

- Adjust the shoe clearance. Turn the adjuster screw (1) and adjust the width of the shoe (2). Check by trial assembly without inserting a key into the motor shaft.

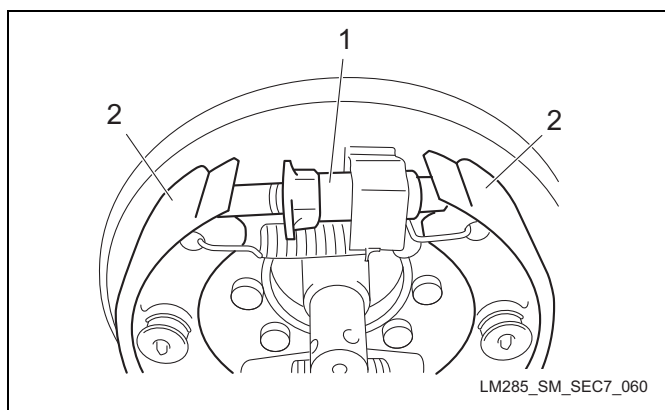

Figure: Main body-68-a

1	Adjuster screw
2	Shoe

Brake wire, rod

Warning

Check to see that the brake wire is free from cracks or damage.

Check to see that the parking brake is effective on a slope and is set free when released. If any abnormality is found, adjust the brake wire and inspect the parking brake system.

Parking brake wire

Adjust the parking brake by tightening the adjuster bolt (3) of the brake wire.

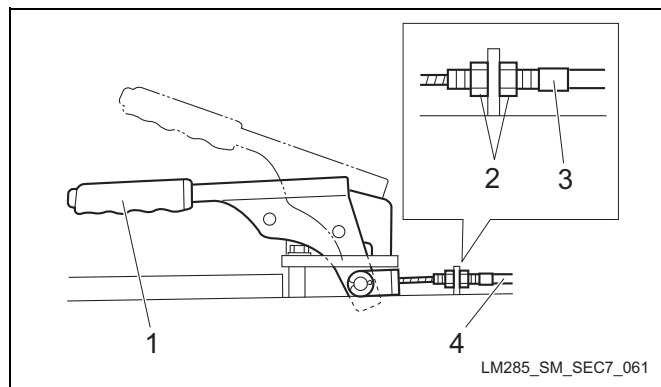

Figure: Main body-69-a

1	Parking brake lever
2	Lock nut
3	Adjuster bolt
4	Brake wire

Foot brake wire

Adjust the foot brake by tightening the adjuster bolt (2) of the foot brake wire.

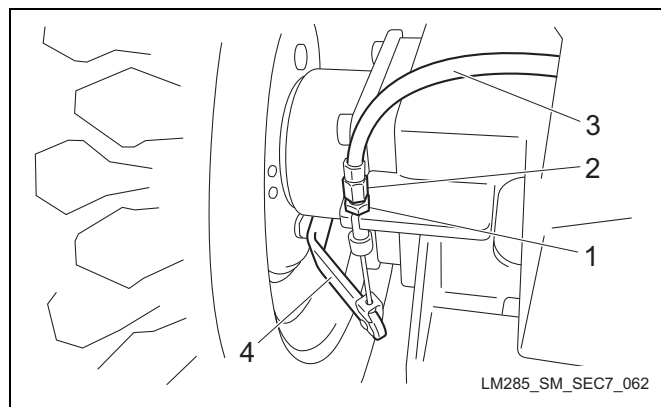

Figure: Main body-70-a

1	Lock nut
2	Adjuster bolt
3	Brake wire
4	Brake lever

Adjustment of the brake wire adjuster bolt

Elongation of the brake wire may cause its stroke to be full, resulting in the brake being weak or locking.

Adjust the pull length of the brake lever with the adjuster bolt (2) of the brake wire (1). Minimize play of the brake lever to adjust the brake so it is set free when the lever is released.

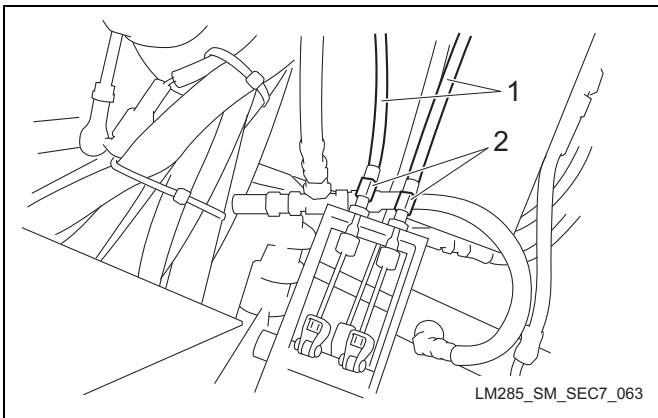

Figure: Main body-71-a

1	Brake wire
2	Adjuster bolt

Traveling cable, Rod

Depending on the use frequency of the traveling pedal, there may be insufficient return of the pedal neutral rod compression spring. Inspect and implement adjustment and other measures if needed.

Important

For neutral adjustment, refer to Owner's operating manual.

Inspection of traveling cable and rod

1. Check to see if the compression spring (2) of the pedal neutral rod (1) is bent or has shrunk. Check to see if the adjusted value of the pedal neutral rod is appropriate. (Refer to "Adjusted value" (Page 7-3))
2. Check to see if the spring pin (4) of the pedal lower part (3) comes off.
3. Check to see if the pedal shaft (5) is bent or worn.
4. Check to see if the pedal neutral rod (1), the rod (9) and the nut of rod end (10) have any looseness.

5. Check to see if the idle lever shaft (6) is bent or worn and if the split pin (7) comes off.

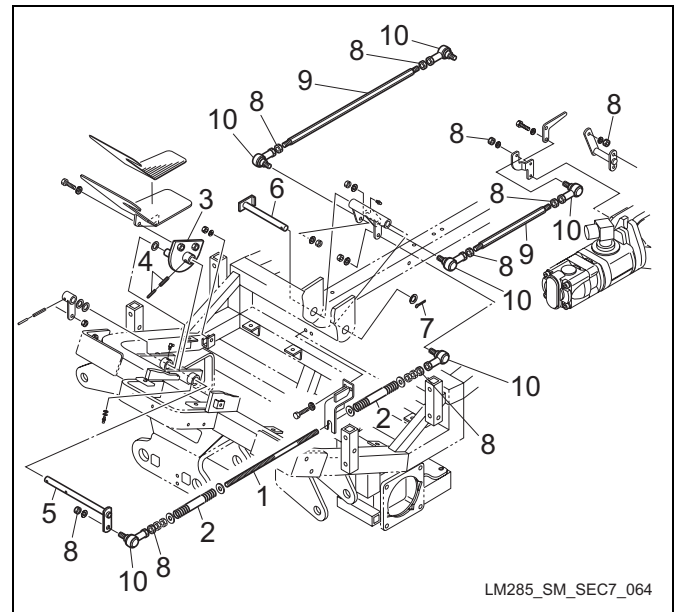

Figure: Main body-72-a

1	Pedal neutral rod
2	Compression spring
3	Pedal lower part
4	Spring pin
5	Pedal shaft
6	Idle lever shaft
7	Split pin
8	Nut
9	Rod
10	Rod end

Adjustment of traveling pedal rod

Adjust the traveling pedal rod in the following two cases.

- When there is no neutrality on the vehicle.
- After the piston pump is removed and installed.

Main body

■ When there is no neutrality on the vehicle.

When there is no neutrality on the vehicle, make the fitting adjustment on the rods and the rod ends.

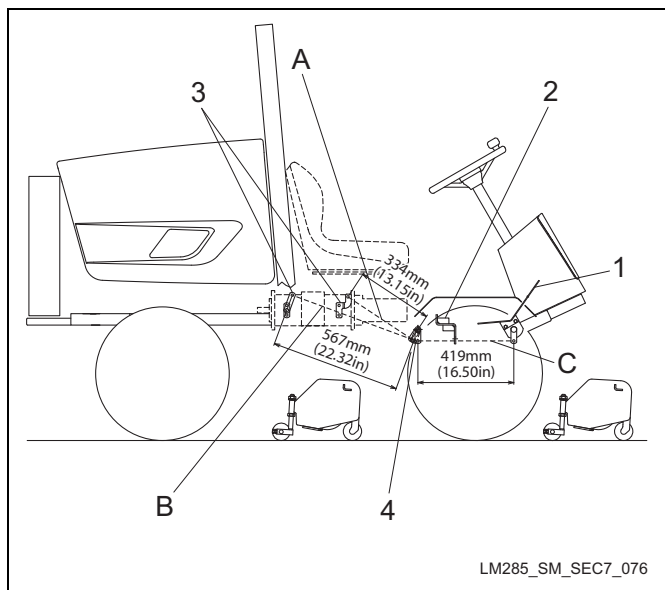

Figure: Main body-73-a

A	Rod for the front wheel
B	Rod for the rear wheel
C	Pedal neutral rod
1	Pedal
2	Neutral bracket
3	Shift lever
4	Idle lever

1. Confirm that the distance of the spring A (2) of the pedal neutral rod (1) is 100mm (3.94 in) and that of the spring B (3) is 75mm (2.95 in). If necessary, loosen the lock nuts (4) and make the adjustment.

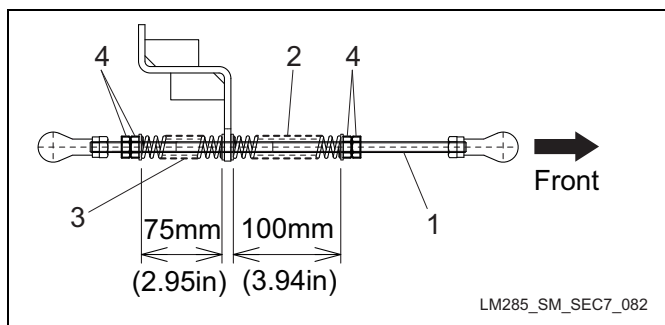

Figure: Main body-74-a

1	Pedal neutral rod
2	Spring A
3	Spring B
4	Lock nut

2. Jack up the vehicle and put it on stable jack stands to raise the whole tires off the ground.

3. Start the engine and rev up to the maximum speed of revolution.
4. In case that the front tires rotate in the forward direction, loosen the lock nuts (2) and turn them in the direction of shrinking the rod for the front wheel (1).
5. In case that the front tires rotate in the reverse direction, turn them in the direction of extending the rod for the front wheel (1).
6. Confirm the positions of the front wheels remaining still and fix with the lock nuts (2).

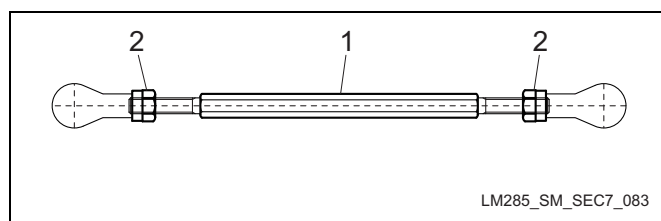

Figure: Main body-75-a

1	Rod for the front wheel
2	Lock nut

7. In case that the rear tires rotate in the forward direction, loosen the lock nuts (2) and turn them in the direction of shrinking the rod for the rear wheel (1).
8. In case that the rear tires rotate in the reverse direction, turn them in the direction of extending the rod for the rear wheel (1).
9. Confirm the positions of the rear wheels remaining still and fix with the lock nuts (2).

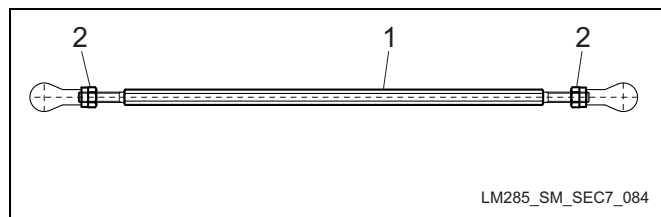

Figure: Main body-76-a

1	Rod for the rear wheel
2	Lock nut

■ After the piston pump is removed and installed.

After the piston pump is removed and installed, make the fitting adjustment as follows.

1. Check to see if there is neutrality in the state of the detent applied. In case that there is no neutrality, the position of the detent is possibly misaligned. For the adjustment, loosen the bolt with hexagon socket head (1) and move and adjust the detent holder (2).

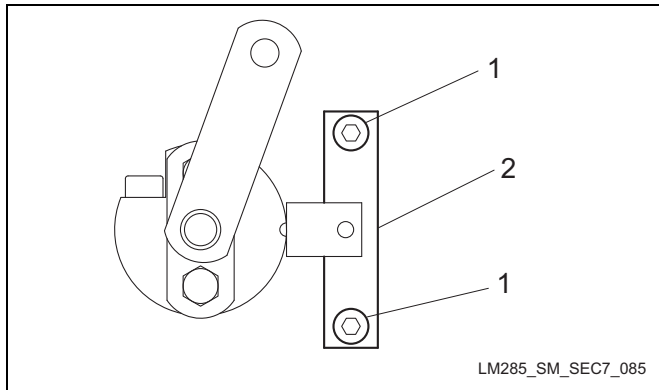

Figure: Main body-77-a

1	Bolt with hexagon socket head
2	Detent holder

2. In the state of the detent (3) of the pump for the front wheel (4) applied, adjust the length of the rod for the front wheel (2) so that the lever of the idle lever (1) to be connected to the pedal will be downward.

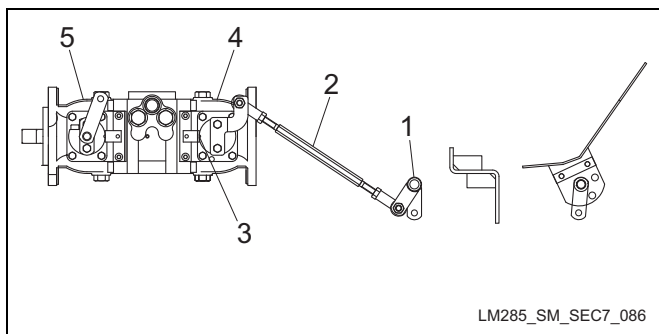

Figure: Main body-78-a

1	Idle lever
2	Rod for the front wheel
3	Detent
4	Pump for the front wheel
5	Pump for the rear wheel

3. When the pedal is depressed fully for forward side, adjust the length of the pedal neutral rod (2) so that the end of the rod can surely contact with the stopper (1) within the range of movement of the trunnion shaft of the pump. At that time, confirm that the pedal neutral rod (2) does not contact with the neutral bracket (4).
4. Depress the pedal for forward side (reverse side) and adjust tension of the spring (3) so that the pedal will return to the position of the detent of the pump for the front wheel applied when the pedal released.

5. Start the engine and confirm neutrality. In case of no neutrality, adjust the spring again.

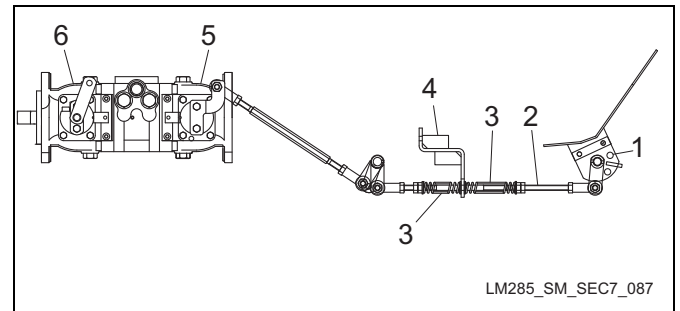

Figure: Main body-79-a

1	Stopper
2	Pedal neutral rod
3	Spring
4	Neutral bracket
5	Pump for the front wheel
6	Pump for the rear wheel

6. After the above-mentioned adjustments (1. to 5.) completed, adjust the length of the rod for the rear wheel (1) so that the detent (4) of the pump for the rear wheel (3) can be applied.
7. Start the engine and confirm neutrality. In case of no neutrality, adjust the length of the rod for the rear wheel (1) again.

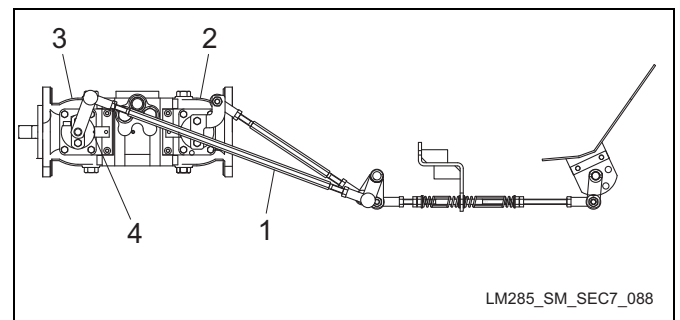

Figure: Main body-80-a

1	Rod for the rear wheel
2	Pump for the front wheel
3	Pump for the rear wheel
4	Detent

8. After the adjustments, tighten the lock nuts of each section for sure.

Throttle wire, rod

Depending on the use frequency, there may be slow movement on the lever, allowance change of an inner wire influenced by R angle of an outer wire and extension of an inner wire. Inspect and make the adjustment if needed.

Main body

Inspection of throttle wire and rod.

1. Confirm that the throttle lever (1) can move smoothly.
2. Confirm that the throttle lever (1) does not return at maximum speed of revolution of the engine.
3. Confirm that the throttle wire (2) is not bent and/or cut.

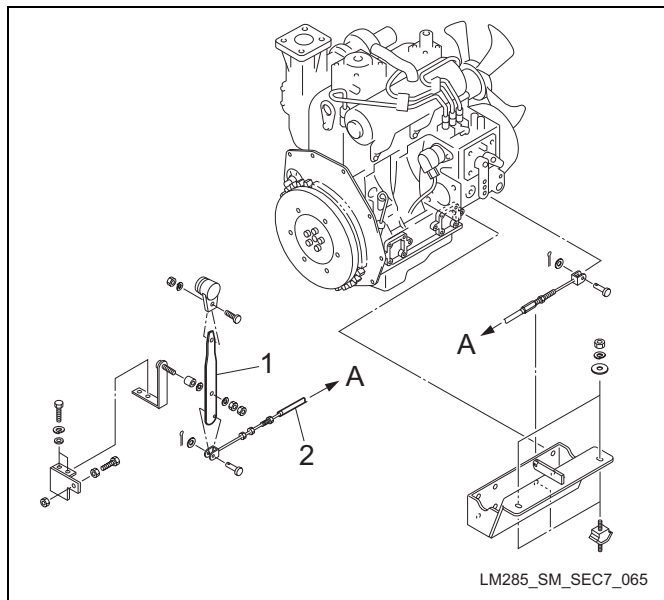

Figure: Main body-81-a

1	Throttle lever
2	Throttle wire

Adjustment of throttle wire

1. Pull the seat handle (1) and slide the seat (2) to the forward end.

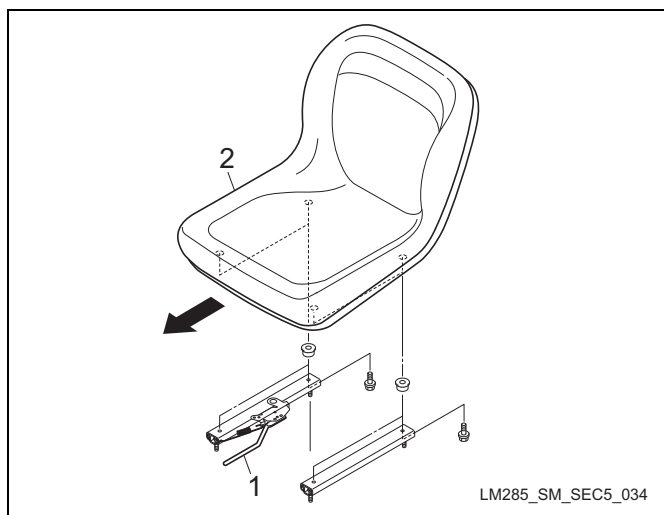

Figure: Main body-82-a

1	Seat handle
2	Seat

2. Remove the bolts (2), S washers (3) and washers (4) behind the seat, which fasten the cover under seat (1).

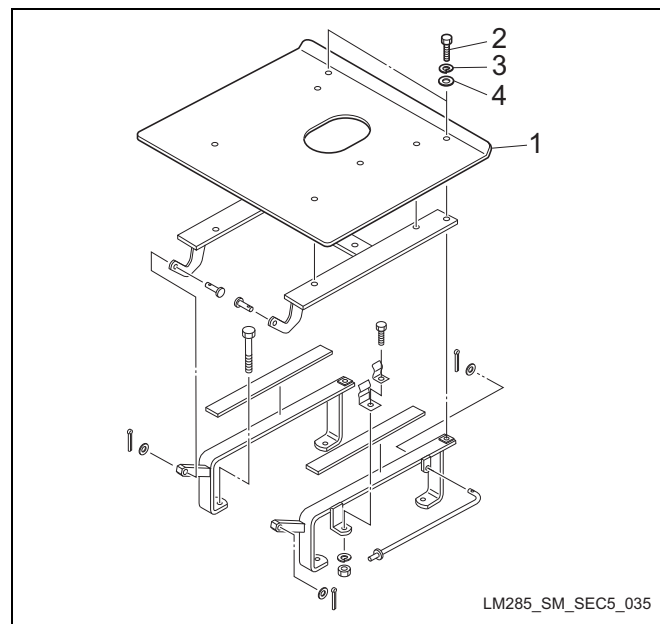

Figure: Main body-83-a

1	Cover under seat
2	Bolt
3	S washer
4	Washer

3. Lift up the seat (1).
4. Insert and fix the stand (2) to the seat mounting plate (3).

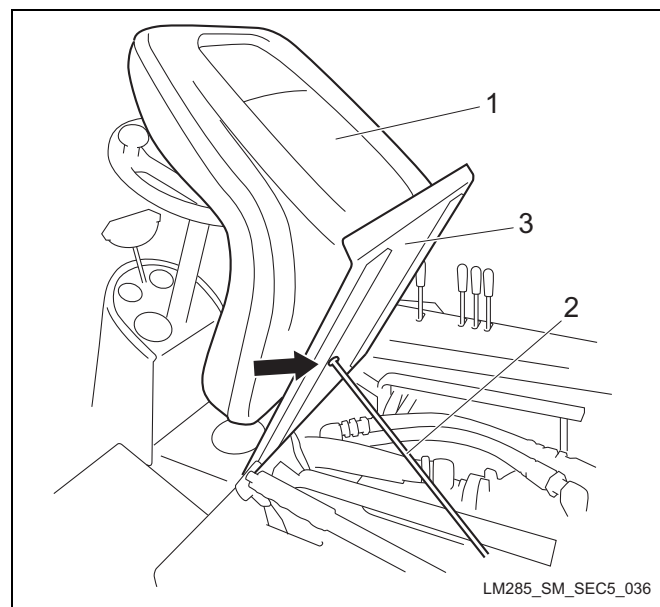

Figure: Main body-84-a

1	Seat
2	Stand
3	Seat mounting plate

5. Tighten the adjuster bolt (2) of the engine (1) side and tighten with the lock nut (3) temporarily.

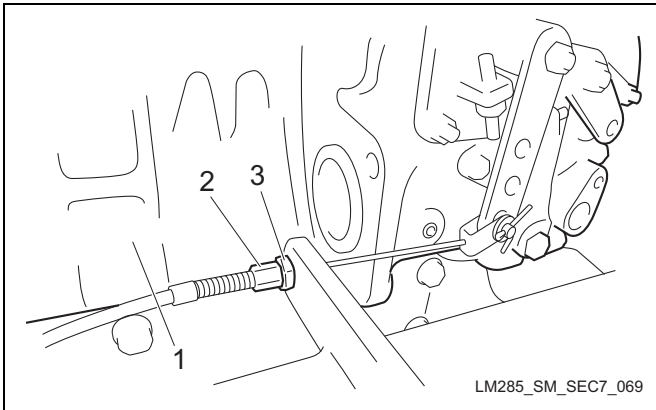

Figure: Main body-85-a

1	Engine
2	Adjuster bolt
3	Lock nut

6. Shift the throttle lever (1) to the idling side and position it so that it can contact with the front cover (2).

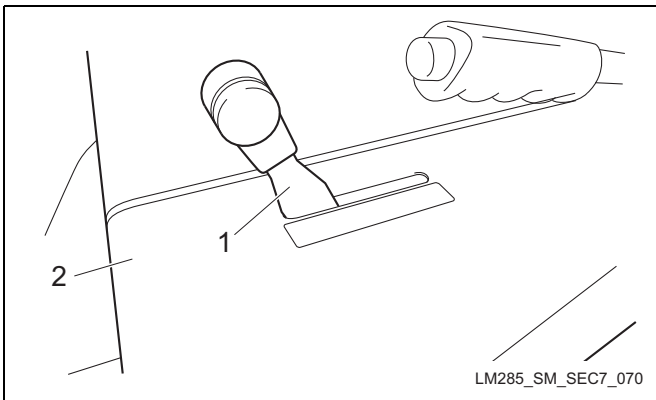

Figure: Main body-86-a

1	Throttle lever
2	Front cover

⚠ Caution

Set the adjuster bolt in the lock nut so that two or more threads of the bolt will come out from the nut.

7. Adjust the adjuster bolt (2) of the throttle lever (1) side to make a little sag on the inner wire (4) of the throttle wire (3) and lock it with the lock nut (5).

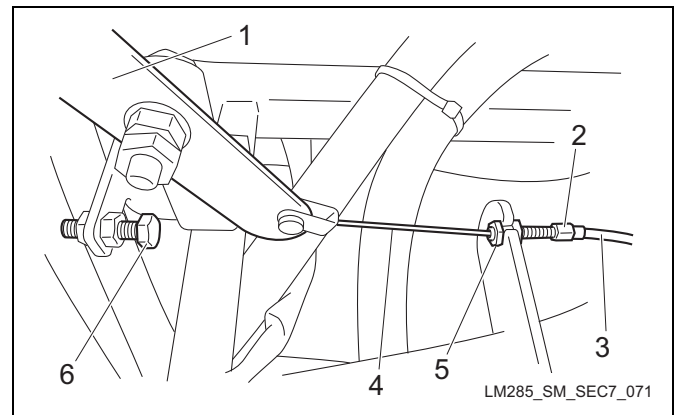

Figure: Main body-87-a

1	Throttle lever
2	Adjuster bolt
3	Throttle wire
4	Inner wire
5	Lock nut
6	Stopper bolt

8. Adjust the adjuster bolt (2) of the engine (1) side and lock it with the lock nut (3). (See Figure: Main body-85-a)
9. Start the engine, pull the throttle lever (1) up to the maximum speed of revolution and adjust the speed for 3,100 rpm by use of the stopper bolt (6)

Reference: The engine speed of revolution is indicated by the tachometer. (Refer to “Layout of electrical components” (Page 6-4))

Toe-in

The original handling ability may be affected adversely by damages etc. on the tie rod and the rod end. Inspect and make the adjustment if needed.

Inspection of tie rod and rod end

1. Confirm that the adjusted value of toe-in is appropriate. (Refer to “Adjusted value” (Page 7-3))
2. Confirm that the tie rod (1) is not bent.
3. Confirm that the rod end (2) is not bent and worn.
4. Confirm that the split pin (3) of the rod end (2) does not come off.

Main body

- Confirm that the split nut (4) of the rod end (2) is not loose.

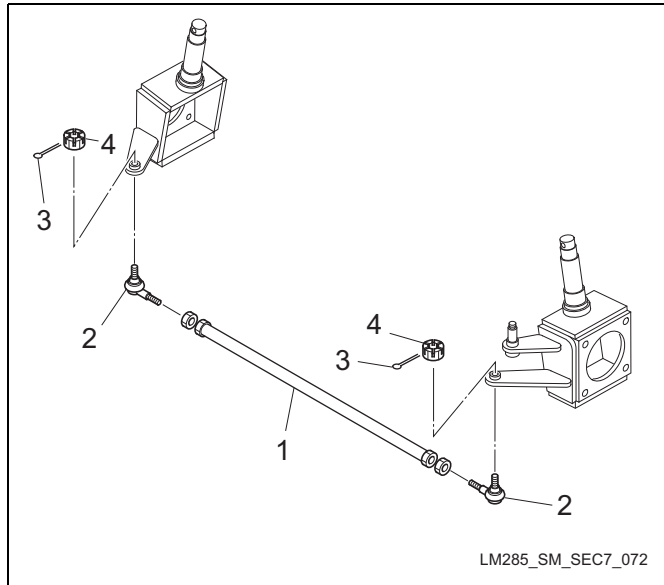

Figure: Main body-88-a

1	Tie rod
2	Rod end
3	Split pin
4	Split nut

- Loosen the right and left lock nuts (1) and adjust by turning the tie rod (2). The adjusted value of toe-in is 0 plus/minus 5mm (0 plus/minus 0.20 in). (Toe-in value=A-B)

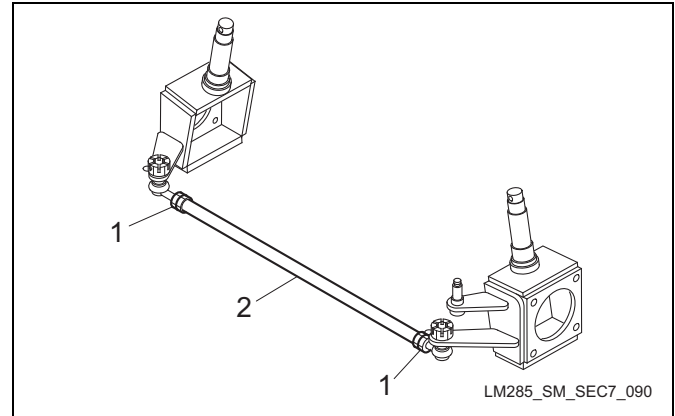

Figure: Main body-90-a

1	Lock nut
2	Tie rod

Adjustment of toe-in

- Adjust for the specified value of air pressure on tires. (Refer to "Tire pressure" (Page 7-2))
- Set the rear wheels straightforward and measure the front width A and the rear width B between the rear wheels.

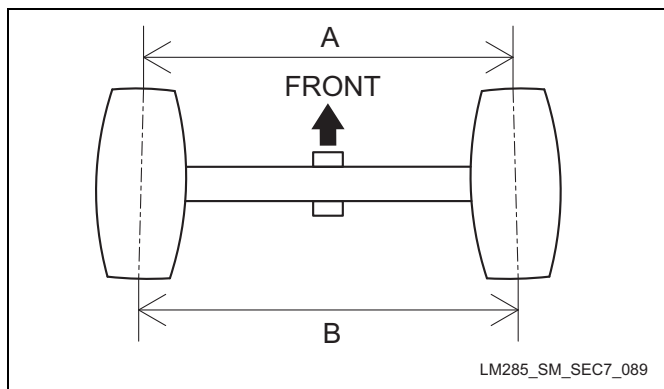

Figure: Main body-89-a

Maintenance	8-2
Specifications	8-2
Adjusted value	8-2
Special tools	8-2
Adjustment	8-4
Adjustment of blade engagement	8-4
Adjustment of cutting height	8-4
Adjustment of cutter adjustment spring	8-4
Removal and installation of each section	8-4
Mower unit	8-4
Bed knife mount base Ass'y	8-5
Reel cutter	8-7
Front roller Ass'y	8-14
Front wheel Ass'y	8-15
Rear roller Ass'y	8-18
Reel cover	8-20
Mower arm	8-23
Inspection and repair of each section	8-24
Reel cutter	8-24
Bedknife	8-30
Front roller	8-31
Front wheel	8-33
Rear roller	8-33
Reel cover	8-34
Mower arm	8-34

Work machine and mower unit

Maintenance

This chapter describes the main inspection and maintenance methods of the LM285 mower unit. Refer to the LM285 Owner's manual and parts catalog for daily inspection, maintenance and handling of this equipment.

For details on installing and removing optional equipments and attachments, refer to the instruction manual for the relevant attachment.

Danger

Follow the instructions below for safe inspection and maintenance.

1. Move the equipment to a level surface to prepare for adjustment and maintenance. Apply the parking brake, stop the engine and remove the key. Make sure that each part has completely stopped its motion before starting procedures for adjustment, maintenance and so on.
2. Do not touch moving parts. Avoid adjustment as much as possible while the engine is running. Keep people away from the area.
3. Use an appropriate chain block, hoist and jack as needed. Securely support the lifted machine with a jack stand or an appropriate block.
4. Use BARONESS genuine parts for replacement parts and accessories.

5. Never start the engine in an enclosed room, for poisoning by carbon monoxide may occur.
6. Never touch the exhaust system while the engine is running or right after the engine has stopped. Its high temperature may cause a burn.
7. Keep flames away from the battery. Batteries emit hydrogen gas and mishandling may cause an explosion.
8. The electrolytic solution in the battery is sulfuric acid. Contact with the electrolytic solution (sulfuric acid) may cause blindness or a burn. Also, it may damage the vehicle if it comes into contact with it.

Specifications

Adjusted value

Mower unit	mm	in
Gap in the spiral of the cutter adjustment spring	1.0	0.040

Grease	Excelite EP No.2 (Urea thickener series No.2)
--------	-----------------------------------------------

Adjustment of gap in the spiral of the cutter adjustment spring

For the adjustment method, refer to “Adjustment of cutter adjustment spring” (Page 8-4).

Special tools

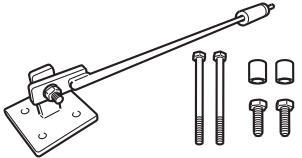
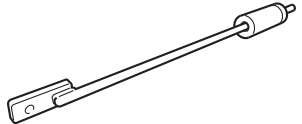
<p>Sliding hammer 318</p>  <p>LM285_SM_SEC8_001</p>	K4802000460	For removal of the gear motor, the housing, etc.
<p>Sliding hammer</p>  <p>LM285_SM_SEC8_002</p>	K480200047D	One of the components of Sliding hammer 318. Use it together with the installation bracket.

Work machine and mower unit

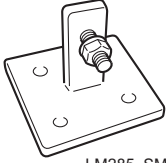
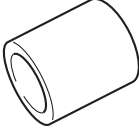
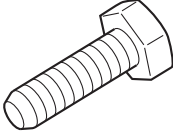
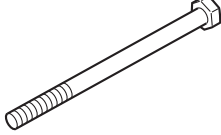
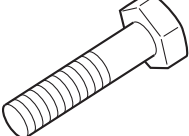
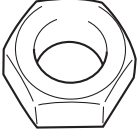
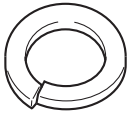
<p>Installation bracket</p>  <p>LM285_SM_SEC8_003</p>	<p>K480200048D</p>	<p>One of the components of Sliding hammer 318. Attach it to the gear motor or the housing.</p>
<p>12.7 collar 17.320.2</p>  <p>LM285_SM_SEC8_004</p>	<p>K6211000012</p>	<p>One of the components of Sliding hammer 318. Set it between the gear motor and the installation bracket.</p>
<p>10 bolt 30</p>  <p>LM285_SM_SEC8_005</p>	<p>K0000100302</p>	<p>One of the components of Sliding hammer 318. Use it for removal of the housing etc.</p>
<p>12 bolt 140</p>  <p>LM285_SM_SEC8_006</p>	<p>K0003121402</p>	<p>One of the components of Sliding hammer 318. Use it for removal of the gear motor.</p>
<p>14 heat-treated bolt 50</p>  <p>LM285_SM_SEC8_007</p>	<p>K0013140502</p>	<p>One of the components of Sliding hammer 318. Use it to attach the sliding hammer to the installation bracket.</p>
<p>14 nut</p>  <p>LM285_SM_SEC8_008</p>	<p>K0100140002</p>	<p>One of the components of Sliding hammer 318. Use it to attach the sliding hammer to the installation bracket.</p>
<p>14S washer</p>  <p>LM285_SM_SEC8_009</p>	<p>K0200140002</p>	<p>One of the components of Sliding hammer 318. Use it to attach the sliding hammer to the installation bracket.</p>

Work machine and mower unit

Adjustment

Adjustment of blade engagement

Make an adjustment, checking the gap between the reel cutter and the bedknife.

For the adjustment method, refer to the owner's operating manual.

Adjustment of cutting height

Make an adjustment for desired height.

For the adjustment method, refer to the owner's operating manual.

Adjustment of cutter adjustment spring

The gap between the reel cutter and the bedknife may change depending on the operating conditions etc. Check and make the adjustment if needed.

1. After the adjustment of blade engagement, make the adjustment on the cutter adjustment spring so that the gap in the spiral will be about 1mm (0.040 in) by use of the pipe with the cutter adjusting screw (1).

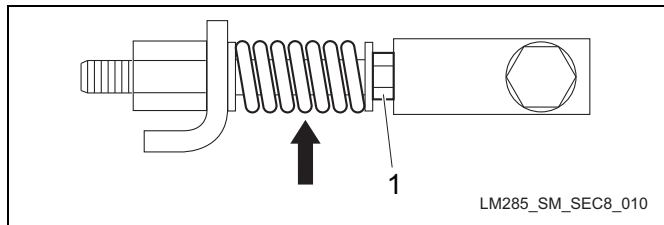

Figure: Work machine and mower unit-1-a

1	Pipe with the cutter adjusting screw
---	--------------------------------------

1. Remove the bolts (2), the S washers (3) and the washers (4) fastening the gear motor (1).

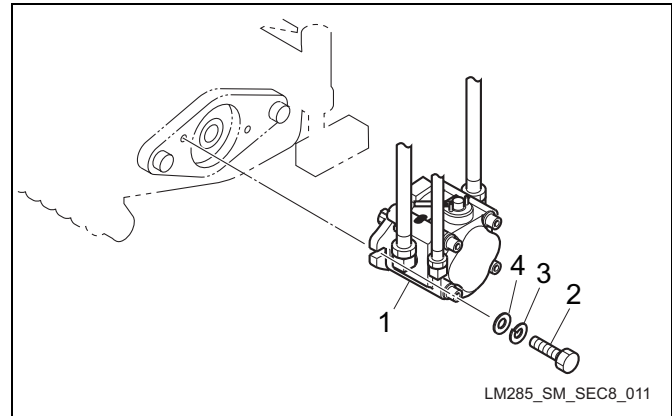

Figure: Work machine and mower unit-2-a

1	Gear motor
2	Bolt
3	S washer
4	Washer

2. Remove the gear motor (1) and the packing (2).

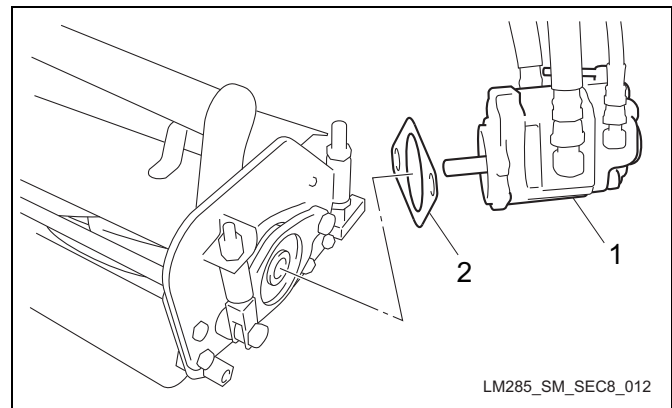

Figure: Work machine and mower unit-3-a

1	Gear motor
2	Packing

Removal and installation of each section

Mower unit

Removal of mower unit

Important

The reel cutter and the bed knife are sharp blades. Exercise adequate care in handling to avoid cutting hands and/or feet.

- Remove the snap pin with stopper (1) and remove the round head pin (2), the collar with hole (3), the washer (4) and the washer (5).

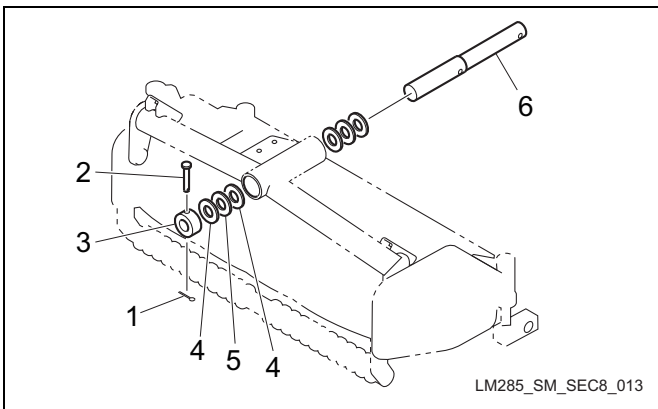

Figure: Work machine and mower unit-4-a

1	Snap pin with stopper
2	Round head pin
3	Collar with hole
4	Washer
5	Washer
6	Shaft

- Draw out and remove the mower unit (1) from the main body.

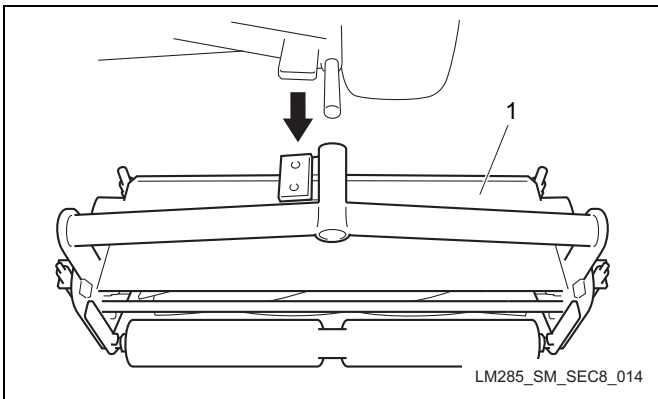

Figure: Work machine and mower unit-5-a

1	Mower unit
---	------------

Installation of mower unit

! Danger

The reel cutter and the bed knife are sharp blades. Exercise adequate care in handling to avoid cutting hands and/or feet.

! Caution

Refer to the tightening torques reference chart. We are not responsible for defects which occurred due to abnormal or overtorque tightening etc.

Important

When inserting the mower unit (1) to the main body, apply grease sufficiently to the inside of the pipe of the mower arm (2) and the shaft (3).

For installation, reverse the removal procedures.

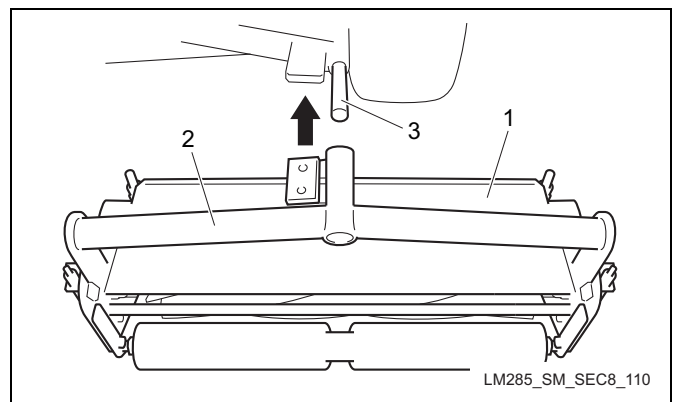

Figure: Work machine and mower unit-6-a

Bed knife mount base Ass'y

Removal of bed knife mount base Ass'y

! Danger

The reel cutter and the bed knife are sharp blades. Exercise adequate care in handling to avoid cutting hands and/or feet.

- Remove the mower unit and turn it back. (Refer to "Removal of mower unit" (Page 8-4))
- Tighten the cutter adjustment nut (1) so that the gap in the spiral of spring will be eliminated to make space between the reel cutter and the bed knife.

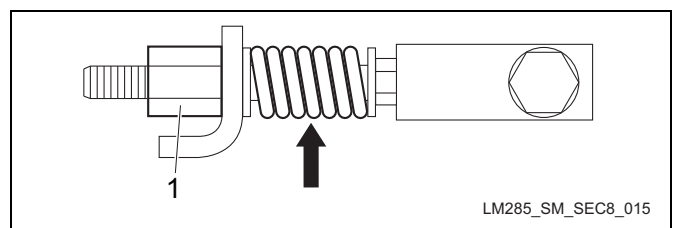

Figure: Work machine and mower unit-7-a

1	Cutter adjustment nut
---	-----------------------

Work machine and mower unit

Warning

Support the bed knife mount base surely when removing the bolts and the nuts.

- Loosen the bolts (2), the washers (3) and the nuts (4) on the right and left rear sides fastening the bed knife mount base (1).
- In the same way, loosen the bolts (5), the washers (6) and the nuts (7) on the right and left front sides.
- Remove all the three bolts on the reel housing side and all the three bolts on the hydraulic motor housing side.

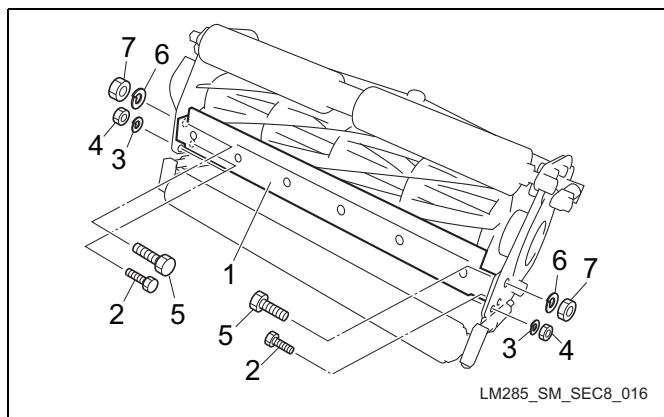

Figure: Work machine and mower unit-8-a

1	Bed knife mount base
2	Bolt
3	Washer
4	Nut
5	Bolt
6	Washer
7	Nut

- Hold the bed knife mount base (1) and draw it out parallel to right and left to remove it from the mower unit.

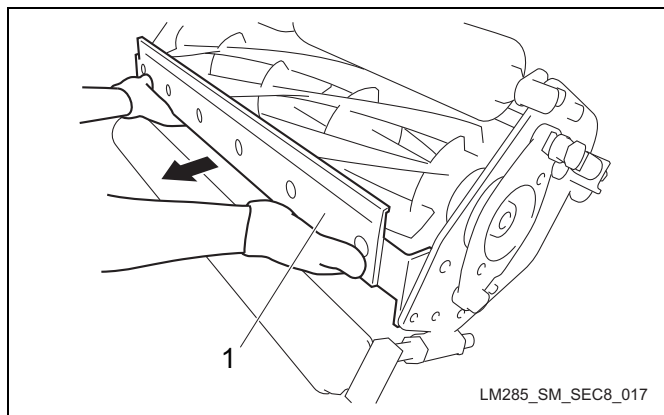

Figure: Work machine and mower unit-9-a

1	Bed knife mount base
---	----------------------

Installation of bed knife mount base Ass'y

Danger

The reel cutter and the bed knife are sharp blades. Exercise adequate care in handling to avoid cutting hands and/or feet.

Caution

Refer to the tightening torques reference chart. We are not responsible for defects which occurred due to abnormal or overtorque tightening etc.

- Insert the bed knife mount base parallel to right and left and install it to the mower unit.

Reference: If it is difficult to insert it by hand, slightly hit it with a plastic hammer.

Do not bring the bed knife into contact with the reel cutter.

- Temporarily install the bolts (2), the washers (3) and the nuts (4) on the right and left rear sides to fasten the bed knife mount base (1).
- In the same way, temporarily install the bolts (5), the washers (6) and the nuts (7) on the right and left front sides.

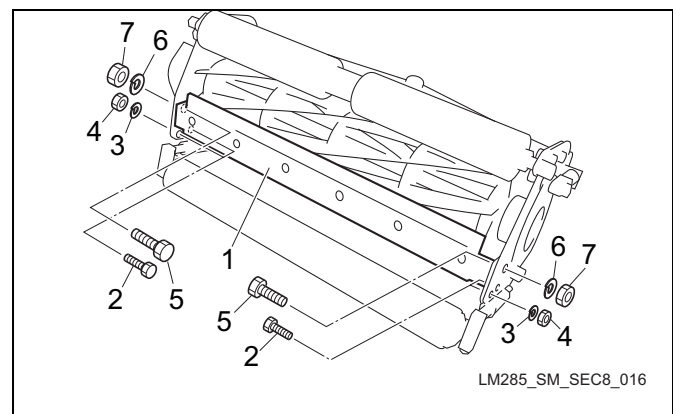

Figure: Work machine and mower unit-10-a

1	Bed knife mount base
2	Bolt
3	Washer
4	Nut
5	Bolt
6	Washer
7	Nut

- Tighten all the three bolts on the reel housing side with a wrench and tighten all the three bolts on the hydraulic motor housing side with a wrench.

5. Implement the adjustment of blade engagement. (Refer to Owner's manual)
6. Make the adjustment on the cutter adjustment spring so that the gap in the spiral will be about 1mm (0.040 in) by use of the pipe with cutter adjusting screw (1).

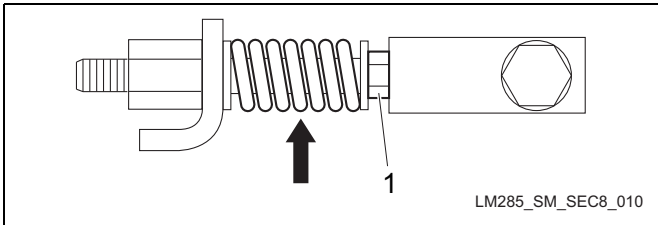

Figure: Work machine and mower unit-11-a

1	Pipe with cutter adjusting screw
---	----------------------------------

7. Implement the adjustment of cutting height. (Refer to Owner's manual)
8. Install the mower unit. (Refer to "Installation of mower unit" (Page 8-5))

Reel cutter

Mower units layout

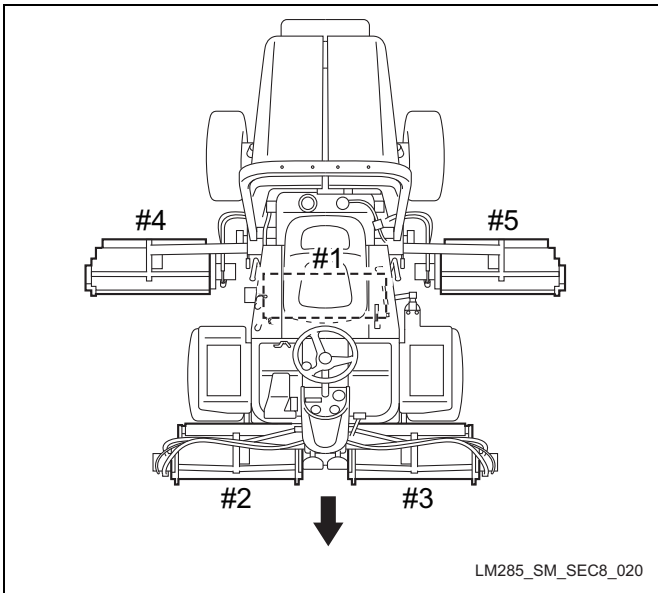

Figure: Work machine and mower unit-12-a

Hydraulic motor housing

The following figures show the position of the hydraulic motor housing for each mower unit.

Note the positions of the bolt holes for the motors.

#1, 2, 5 mower

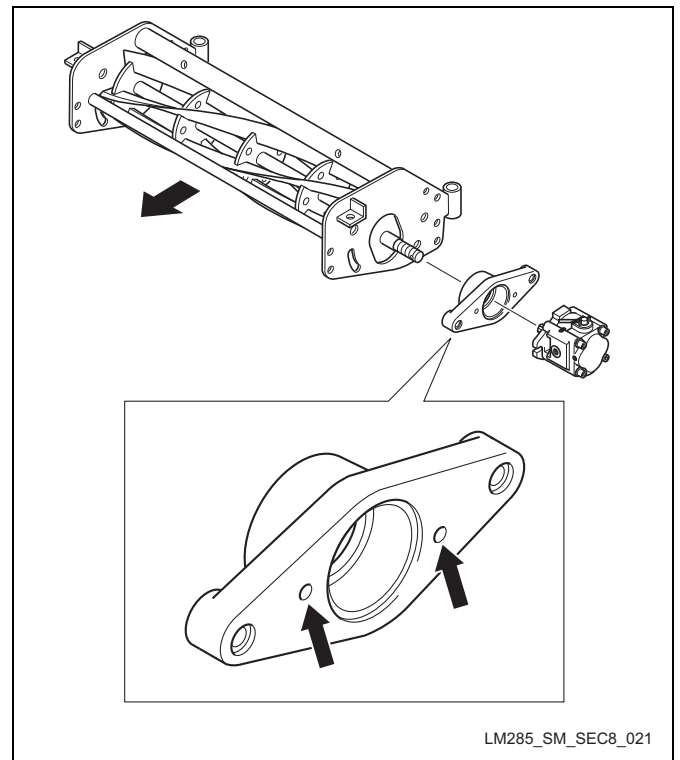

Figure: Work machine and mower unit-13-a

#3, 4 mower

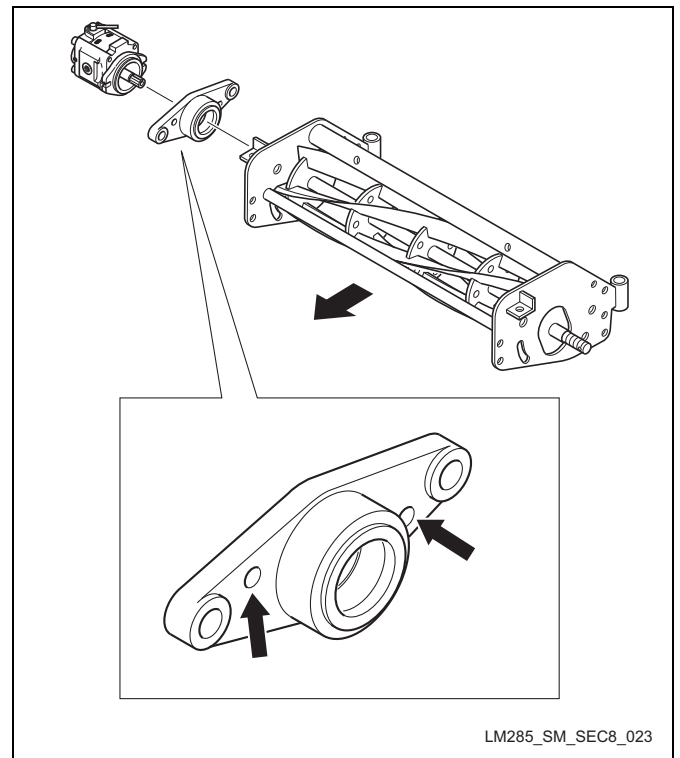

Figure: Work machine and mower unit-14-a

Work machine and mower unit

Removal of reel cutter

Danger

The reel cutter and the bed knife are sharp blades. Exercise adequate care in handling to avoid cutting hands and/or feet.

1. Remove the mower unit and turn it back. (Refer to "Removal of mower unit" (Page 8-4))
2. Remove the bed knife mount base Ass'y. (Refer to "Removal of bed knife mount base Ass'y" (Page 8-5))
3. Remove the bolts (3) and the S washers (4) fastening the reel housing cover (1) and remove the reel housing cover (1) and the packing (2).

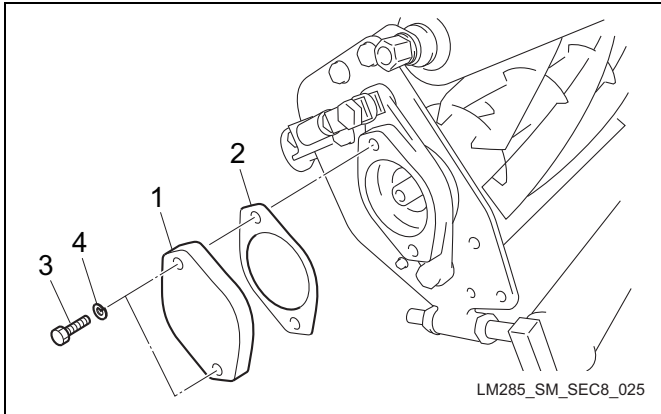

Figure: Work machine and mower unit-15-a

1	Reel housing cover
2	Packing
3	Packing
4	S washer

Important

The split nut is tightened. For removal of the nut, loosen it with a box wrench or an air pressure tool etc. while locking the reel cutter with a wooden hammer etc.

4. Draw out the split pin (1) and remove the split nut (2) and the collar (3).

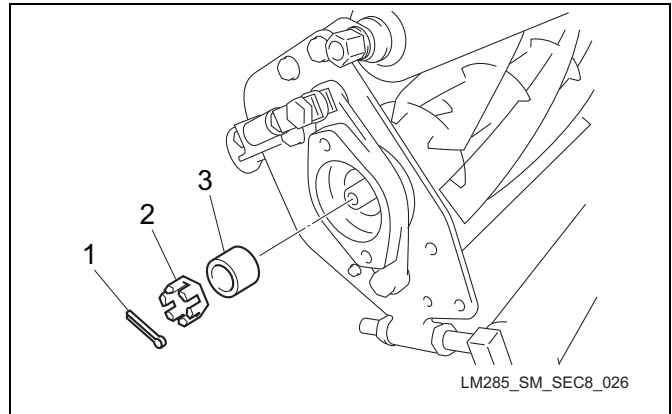

Figure: Work machine and mower unit-16-a

1	Split pin
2	Split nut
3	Collar

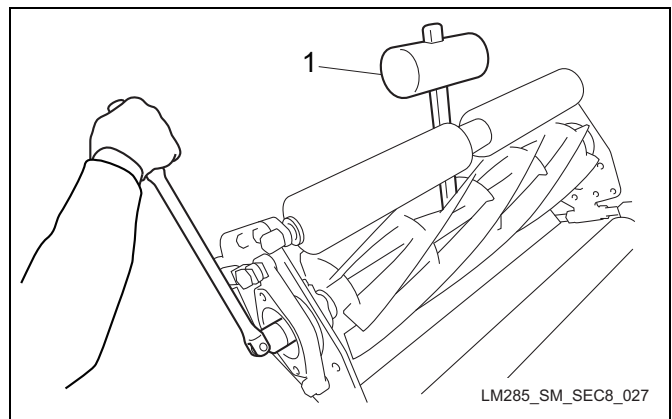

Figure: Work machine and mower unit-17-a

1	Wooden hammer
---	---------------

5. Remove the right and left cutter adjustment sections (1).

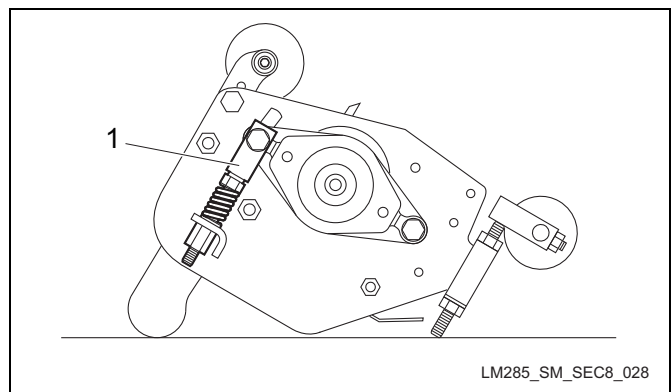

Figure: Work machine and mower unit-18-a

1	Cutter adjustment section
---	---------------------------

Work machine and mower unit

- Remove the right and left cutter adjustment nuts (1) and the washers (2).

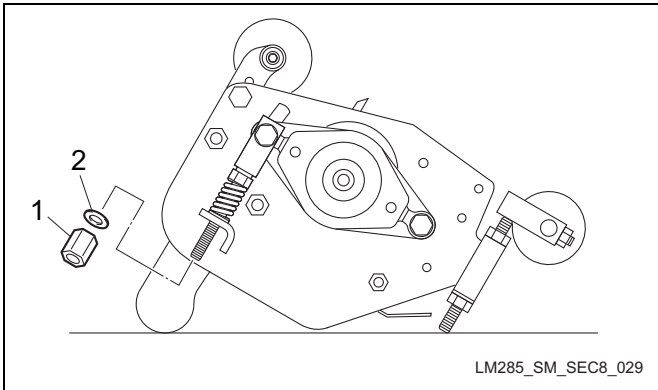

Figure: Work machine and mower unit-19-a

1	Cutter adjustment nut
2	Washer

Important

Remove the bolts, the washers and the nuts while lifting up the reel cutter.

- Remove the nuts (2) and the washers (3) fastening the right and left housing bolts (1).
- Loosen the right and left housing bolts (1) and remove the disk spring washers (4) and the washer (5) and then remove all the housing bolts (1) and the cutter adjustment sections.

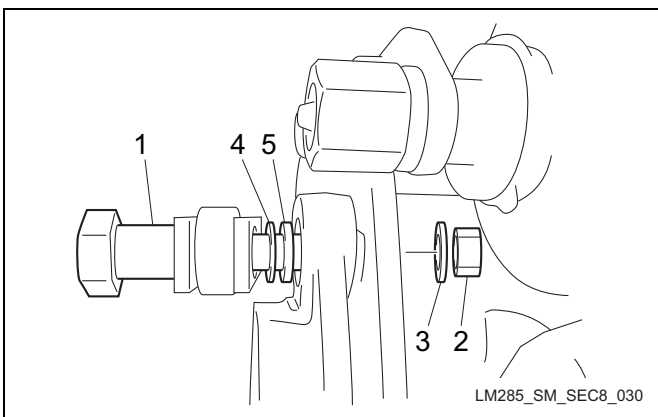

Figure: Work machine and mower unit-20-a

1	Housing bolt
2	Nut
3	Washer
4	Disk spring washer
5	Washer

- Remove the nuts (3) fastening the right and left housing support shaft bolts (1) and loosen the housing support shaft bolts (1) and then remove the support shaft bolts (1) and the washers (2).

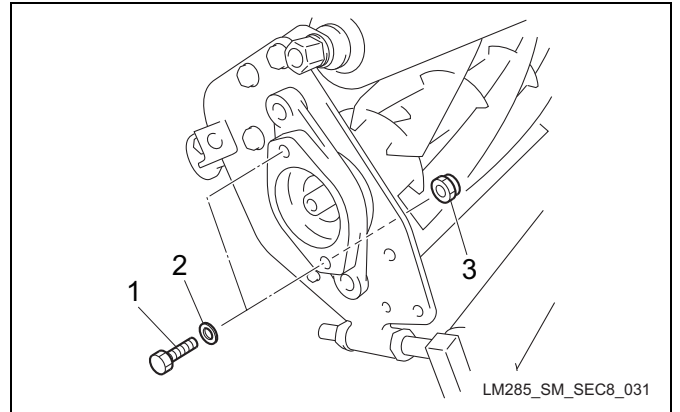

Figure: Work machine and mower unit-21-a

1	Support shaft bolt
2	Washer
3	Nut

- Attach the installation bracket (1) to the housing (3) with the bolts (2) fastening the gear motor. The bolts fit the two holes (dia. 10mm) of the installation bracket.
- Attach the sliding hammer (4) to the installation bracket (1) with the bolt (5) and the nut (6).

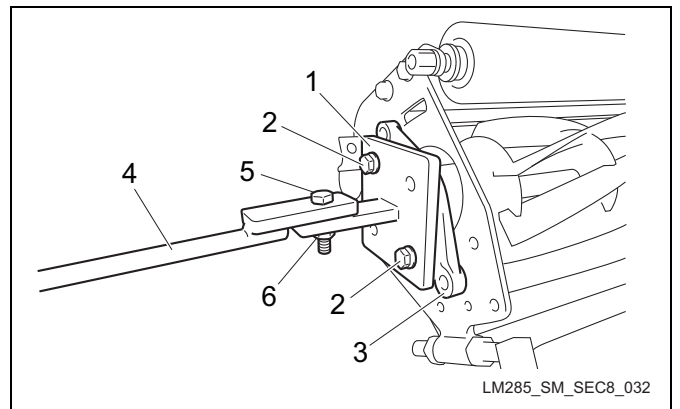

Figure: Work machine and mower unit-22-a

1	Installation bracket
2	Bolt
3	Housing
4	Sliding hammer
5	Bolt
6	Nut

Work machine and mower unit

Caution

When sliding the hammer, exercise care in the hold position to avoid pinching the hand.

Important

For removal of the housing, work in a twosome while lifting up the reel cutter.

Important

The hydraulic motor housings differ according to the mower units. Remember which mower unit the housing fits.

- Slide the hammer (1) to remove the housing (2) with the impact.

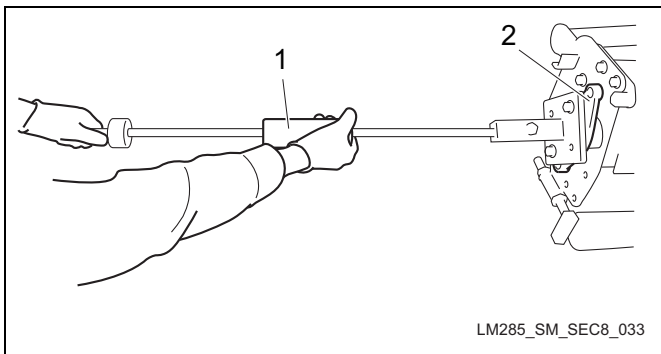

Figure: Work machine and mower unit-23-a

1	Hammer
2	Housing

- In the same way, remove the housing on the opposite side.

Important

The reel cutters differ according to the mower units. Remember which mower the reel cutter fits.

- Lift one side of the reel cutter (1) at a time to remove it from the mower unit.

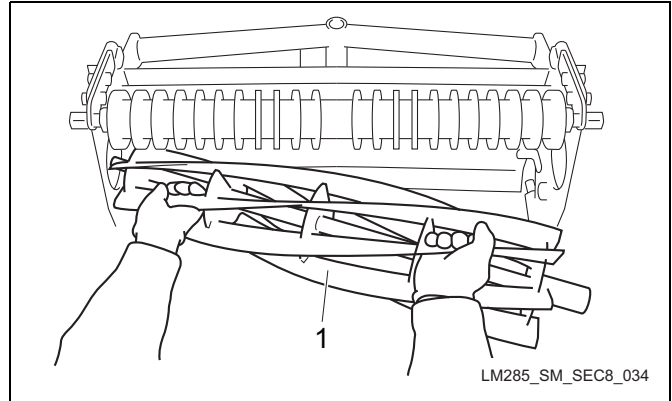

Figure: Work machine and mower unit-24-a

1	Reel cutter
---	-------------

Installation of reel cutter

Danger

The reel cutter and the bed knife are sharp blades. Exercise adequate care in handling to avoid cutting hands and/or feet.

Caution

Refer to the tightening torques reference chart. We are not responsible for defects which occurred due to abnormal or overtorque tightening etc.

Important

The reel cutters and the hydraulic motor housings differ according to the mower units. Exercise care in the difference.

- Locate the reel cutter in the proper direction. Lift the reel cutter (1) and insert the right and left housings (2).

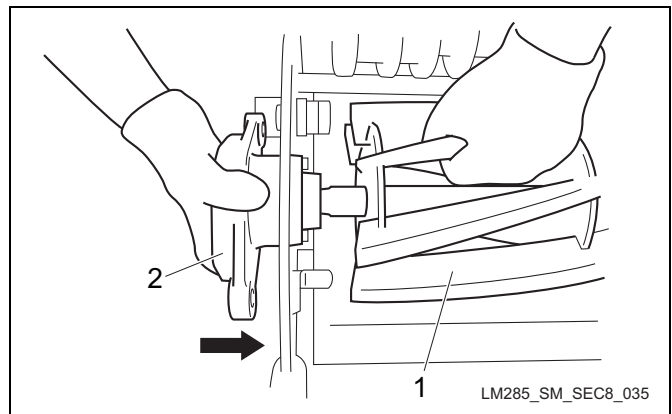

Figure: Work machine and mower unit-25-a

Work machine and mower unit

1	Reel cutter
2	Housing

Important

Knock in the housing while lifting up the reel cutter.

- Temporarily knock in the reel housing (1) with a plastic hammer.

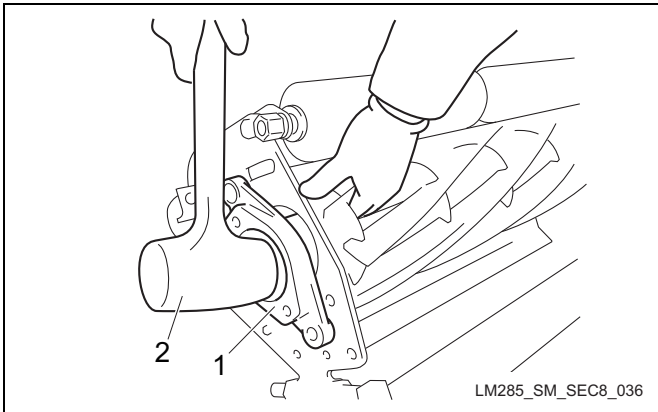

Figure: Work machine and mower unit-26-a

1	Reel housing
2	Plastic hammer

- Temporarily install the support shaft bolts (1), the washers (2) and the nuts (3) on the hydraulic motor housing side.

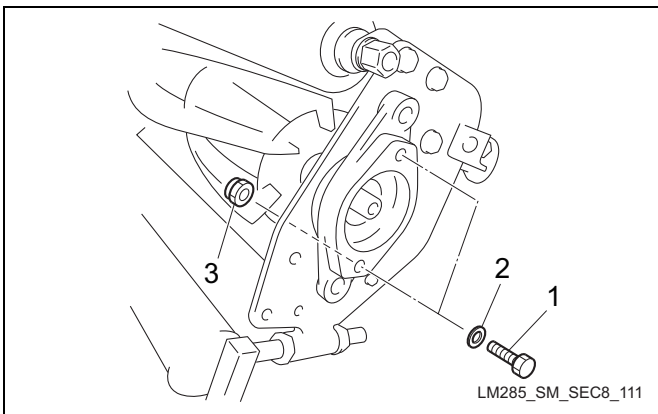

Figure: Work machine and mower unit-27-a

1	Support shaft bolt
2	Washer
3	Nut

- Install the cutter adjustment section with the housing bolt (1), the disk spring washer (2) and the washer (3) on the hydraulic motor side and temporarily install the washer (4) and the nut (5).

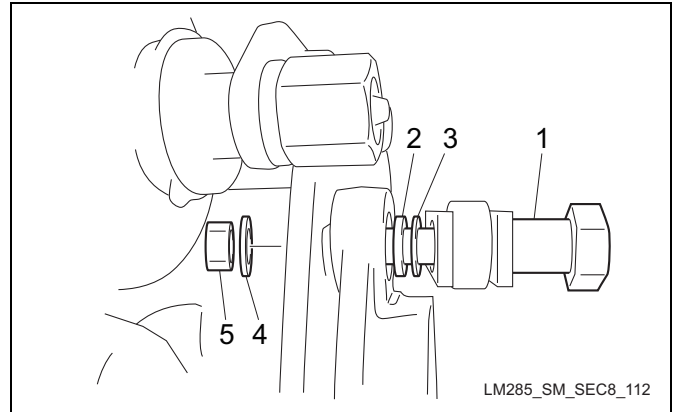

Figure: Work machine and mower unit-28-a

1	Housing bolt
2	Disk spring washer
3	Washer
4	Washer
5	Nut

- Temporarily install the cutter adjustment nut (1) and the washer (2) on the hydraulic motor housing side.

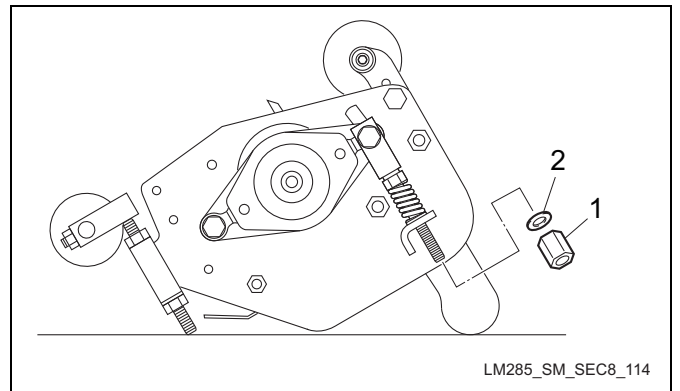

Figure: Work machine and mower unit-29-a

1	Cutter adjustment nut
2	Washer

Important

Knock in the housing while lifting up the reel cutter.

- Knock in the reel housing (1) to the frame with 6207 bearing driver (2) and a plastic hammer (3) until the play between the frame and the reel housing is eliminated.

Work machine and mower unit

Reference: If there is a gap between the frame and the reel housing after knock it into the reel housing side, knock it into the hydraulic motor housing side to eliminate the gap.

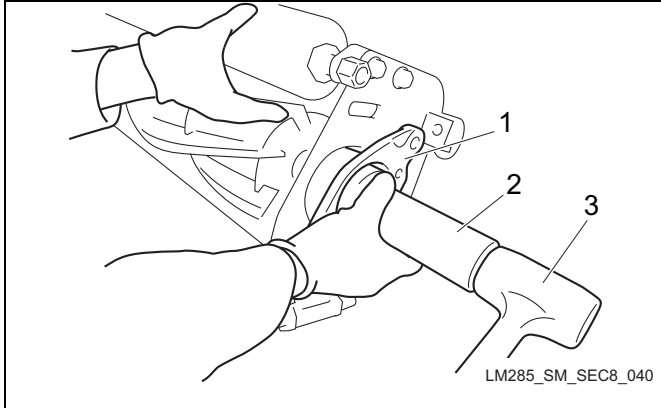

Figure: Work machine and mower unit-30-a

1	Reel housing
2	6207 bearing driver
3	Plastic hammer

7. Install the cutter adjustment section with the housing bolt (1), the disk spring washer (4) and the washer (5) on the reel housing side and temporarily install the washer (3) and the nut (2).

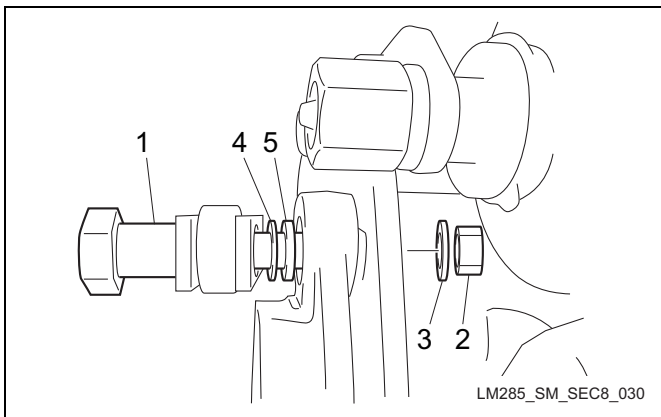

Figure: Work machine and mower unit-31-a

1	Housing bolt
2	Nut
3	Washer
4	disk spring washer
5	Washer

8. Temporarily install the cutter adjustment nut (1) and the washer (2) on the reel housing side.

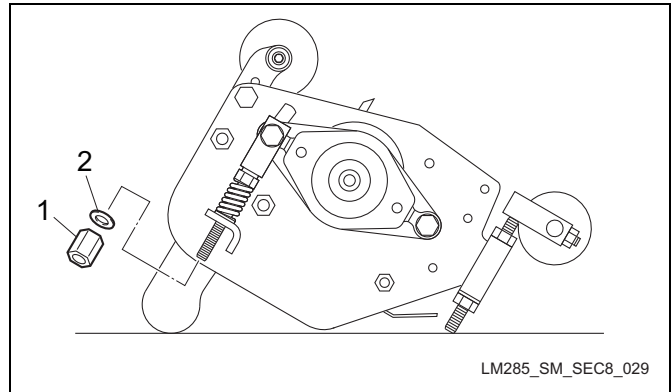

Figure: Work machine and mower unit-32-a

1	Cutter adjustment nut
2	Washer

9. Install the support shaft bolts (1) and the washers (2) on the reel housing side in the state that there is no play but that the housing can move. (Loosen by about 1/4 turn after fully tightening by hand.) And Lock it with the nuts (3).

10. In the same way, install them on the hydraulic motor housing side.

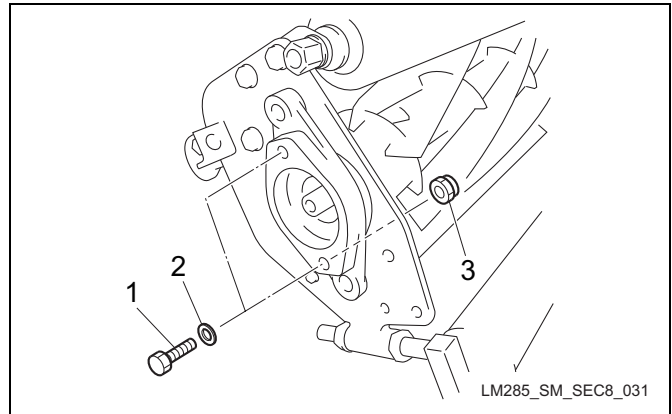

Figure: Work machine and mower unit-33-a

1	Support shaft bolt
2	Washer
3	Nut

Work machine and mower unit

11. Tighten the nuts (2) fastening the right and left housing bolts (1) in the state that there is no play but that the housing can move. (Loosen by about 1/4 turn after fully tightening by hand.)

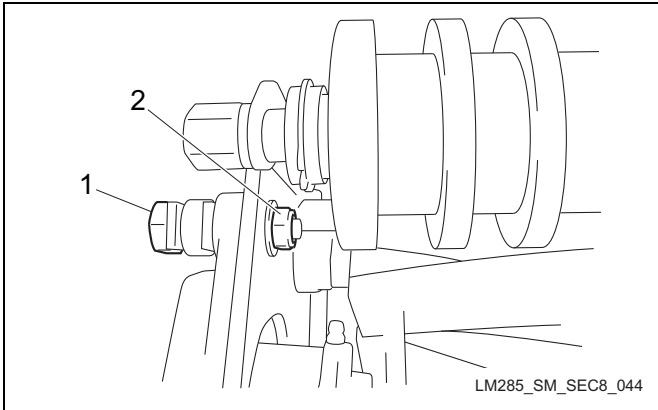

Figure: Work machine and mower unit-34-a

1	Housing bolt
2	Nut

Important

For installation of the split nut, tighten it with a box wrench or an air pressure tool etc. while locking the reel cutter with a wooden hammer etc.

12. Install the collar (3), the split pin (2) and the split pin (1) on the reel housing side.

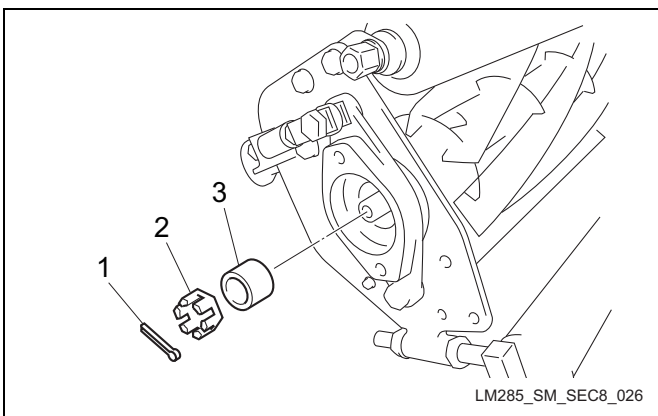

Figure: Work machine and mower unit-35-a

1	Split pin
2	Split nut
3	Collar

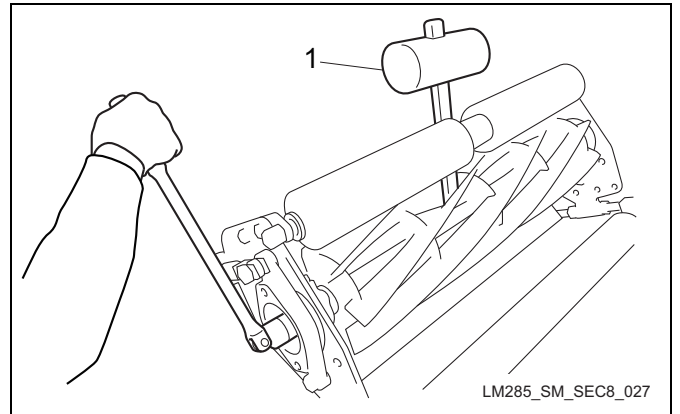

Figure: Work machine and mower unit-36-a

1	Wooden hammer
---	---------------

13. Install the reel housing cover (1) and the packing (2) with the bolts (3) and the S washers (4)

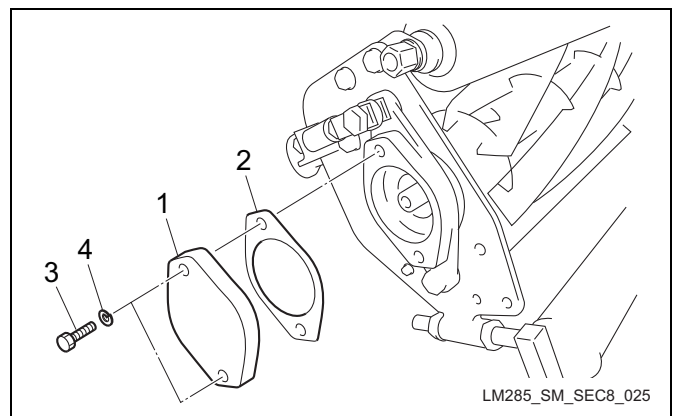

Figure: Work machine and mower unit-37-a

1	Reel housing cover
2	Packing
3	Bolt
4	S washer

14. Tighten the cutter adjustment nut (1) so that the gap in the spiral of spring will be eliminated.

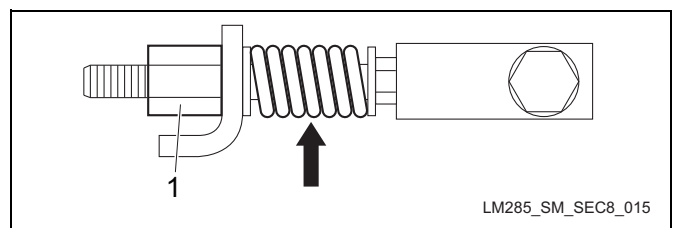

Figure: Work machine and mower unit-38-a

1	Cutter adjustment nut
---	-----------------------

Work machine and mower unit

15. Install the bed knife mount base Ass'y. (Refer to "Installation of bed knife mount base Ass'y" (Page 8-6))
16. Implement the adjustment of blade engagement. (Refer to Owner's manual)
17. Make the adjustment on the cutter adjustment spring so that the gap in the spiral will be about 1mm (0.040 in) by use of the pipe with cutter adjusting screw (1).

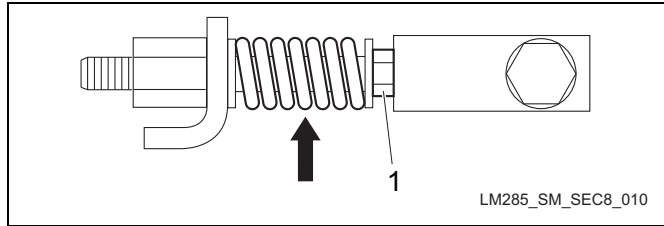

Figure: Work machine and mower unit-39-a

1	Pipe with cutter adjusting screw
---	----------------------------------

18. Implement the adjustment of cutting height. (Refer to Owner's manual)
19. Install the mower unit. (Refer to "Installation of mower unit" (Page 8-5))

Front roller Ass'y

Removal of front roller Ass'y

⚠ Danger

The reel cutter and the bed knife are sharp blades. Exercise adequate care in handling to avoid cutting hands and/or feet.

1. Remove the mower unit and turn it back. (Refer to "Removal of mower unit" (Page 8-4))
2. Remove the bolts (2), the washers (3), the S washers (4) and the nuts (5) fastening the right and left roller brackets (1).

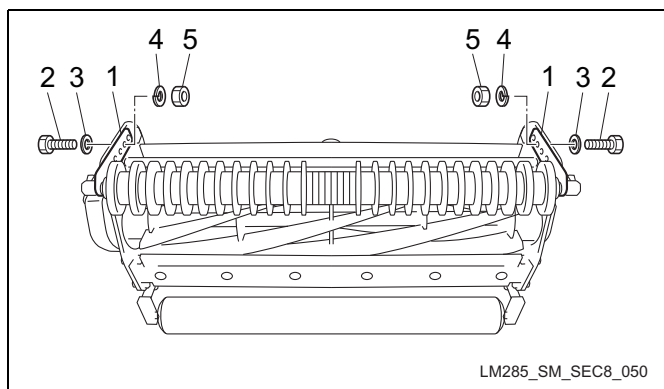

Figure: Work machine and mower unit-40-a

1	Roller bracket
2	Bolt
3	Washer
4	S washer
5	Nut

3. Lift up and draw out the front roller (1) together with the roller brackets (2) parallel to right and left to remove them from the mower unit.

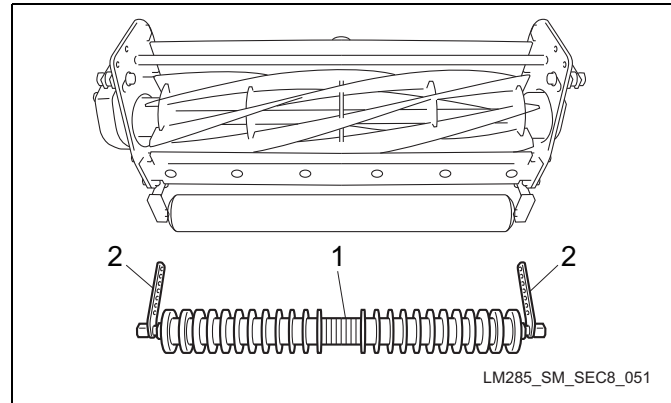

Figure: Work machine and mower unit-41-a

1	Front roller
2	Roller bracket

4. Remove the nuts (3) and the S washers (2) fastening the right and left roller brackets (1) and remove the roller brackets (1).

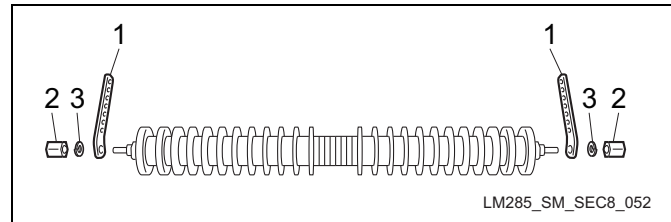

Figure: Work machine and mower unit-42-a

1	Roller bracket
2	Nut
3	S washer

Installation of front roller Ass'y

⚠ Danger

The reel cutter and the bed knife are sharp blades. Exercise adequate care in handling to avoid cutting hands and/or feet.

⚠ Caution

Refer to the tightening torques reference chart. We are not responsible for defects which occurred due to abnormal or overtorque tightening etc.

Important

When installing the front roller Ass'y to the main body, exercise care in the direction of installation.

1. According to the position of desired cutting height, reverse the removal procedures.

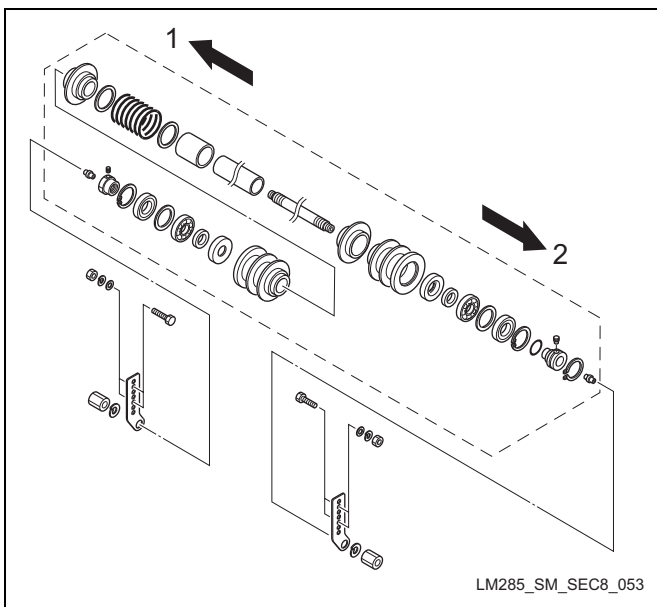

Figure: Work machine and mower unit-43-a

1	Motor housing side
2	Reel housing side

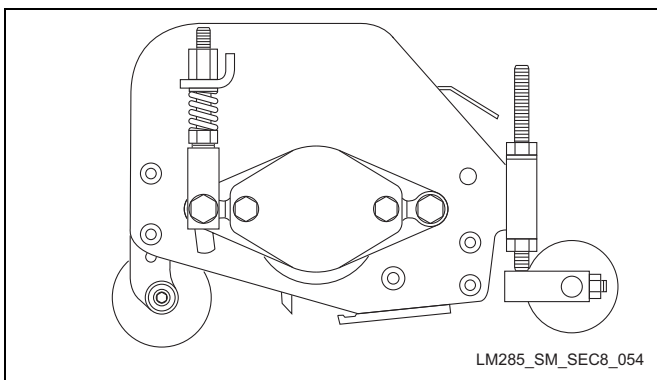

Figure: Work machine and mower unit-44-a

2. Rotate the roller by hand and confirm the state of rotation.
3. Implement the adjustment of cutting height. (Refer to Owner's manual)

4. Install the mower unit. (Refer to "Installation of mower unit" (Page 8-5))

Front wheel Ass'y

Removal of front wheel Ass'y

⚠ Danger

The reel cutter and the bed knife are sharp blades. Exercise adequate care in handling to avoid cutting hands and/or feet.

■ #1 mower

1. Remove the mower unit and turn it back. (Refer to "Removal of mower unit" (Page 8-4))
2. Remove the bolts (2), the washers (3), the S washers (4) and the nuts (5) fastening the right and left roller brackets (1) and remove the front wheel Ass'y.

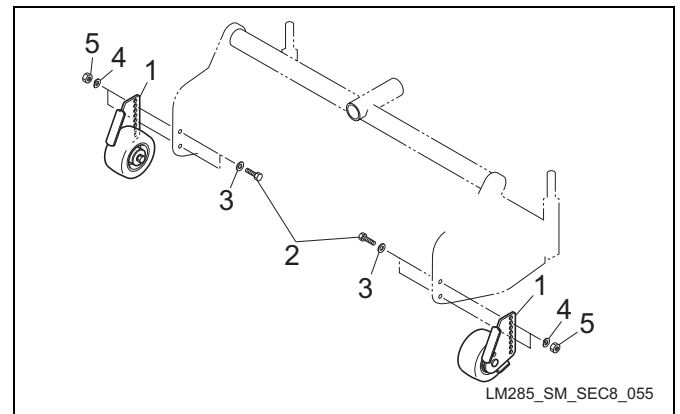

Figure: Work machine and mower unit-45-a

1	Roller bracket
2	Bolt
3	Washer
4	S washer
5	Nut

■ #2, #3, #4, #5 mower

1. Remove the mower unit and turn it back. (Refer to "Removal of mower unit" (Page 8-4))
2. Remove the bolts (2), the washers (3), the S washers (4) and the nuts (5) fastening the right and left roller brackets (1).

Work machine and mower unit

3. Lift up and draw out the stay pipe (6) together with the roller brackets parallel to right and left to remove them from the mower unit.

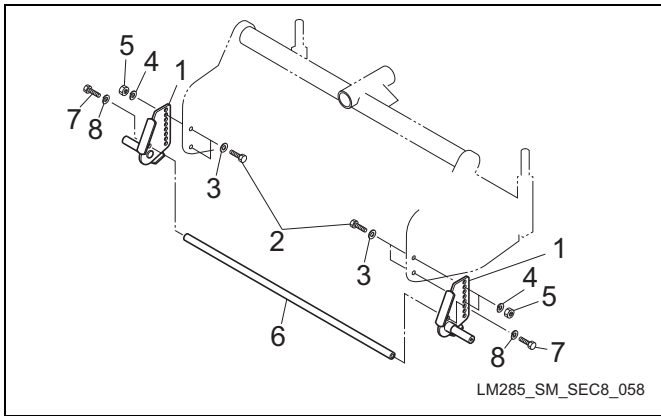

Figure: Work machine and mower unit-46-a

1	Roller bracket
2	Bolt
3	Washer
4	S washer
5	Nut
6	Stay pipe
7	Bolt
8	S washer

Installation of front wheel Ass'y

Danger

The reel cutter and the bed knife are sharp blades. Exercise adequate care in handling to avoid cutting hands and/or feet.

■ #1 mower

Caution

Refer to the tightening torques reference chart. We are not responsible for defects which occurred due to abnormal or overtorque tightening etc.

Important

When installing the front wheel Ass'y to the main body, exercise care in the direction of installation.

1. According to the position of desired cutting height, reverse the removal procedures.

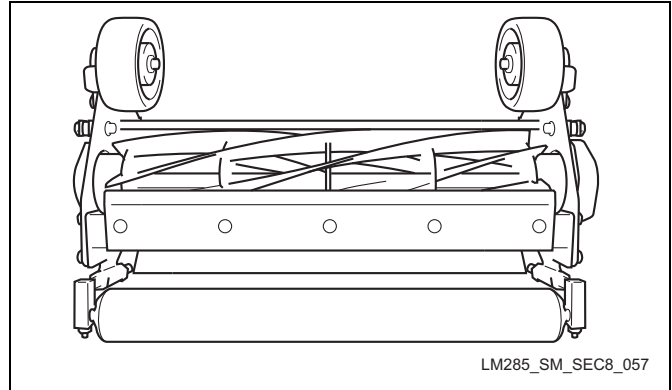

Figure: Work machine and mower unit-47-a

2. Rotate the wheel by hand and confirm the state of rotation.
3. Implement the adjustment of cutting height. (Refer to Owner's manual)
4. Install the mower unit. (Refer to "Installation of mower unit" (Page 8-5))

■ #2, #3, #4, #5 mower

Caution

Refer to the tightening torques reference chart. We are not responsible for defects which occurred due to abnormal or overtorque tightening etc.

Important

When installing the roller brackets to the main body, exercise care in the direction of installation.

1. According to the position of desired cutting height, temporarily install the roller brackets (1) with the bolts (2), the washers (3), the S washers (4) and the nuts (5).
2. Install the stay pipe (6) with the bolts (7) and the S washers (8).

Work machine and mower unit

- Tighten the bolts (2), the washers (3), the S washers (4) and the nuts (5) fastening the roller brackets (1).

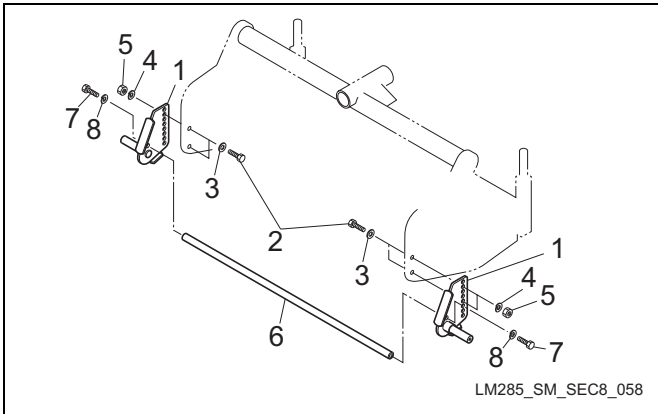

Figure: Work machine and mower unit-48-a

1	Roller bracket
2	Bolt
3	Washer
4	S washer
5	Nut
6	Stay pipe
7	Bolt
8	S washer

- Install the wheel parts to the roller bracket left (1) in the order shown on the following figure.

Reference: Use a special tool if the bearing cannot be inserted.

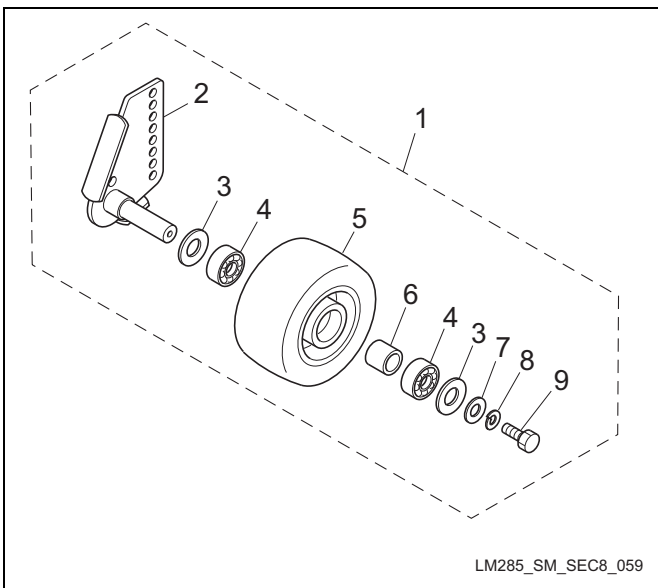

Figure: Work machine and mower unit-49-a

1	Front wheel left Ass'y
2	Roller bracket left
3	Washer
4	Bearing
5	Rubber wheel
6	Collar
7	Wheel clamping washer
8	S washer
9	Bolt

- Install the wheel parts to the roller bracket right (1) in the order shown on the following figure.

Reference: Use a special tool if the bearing cannot be inserted.

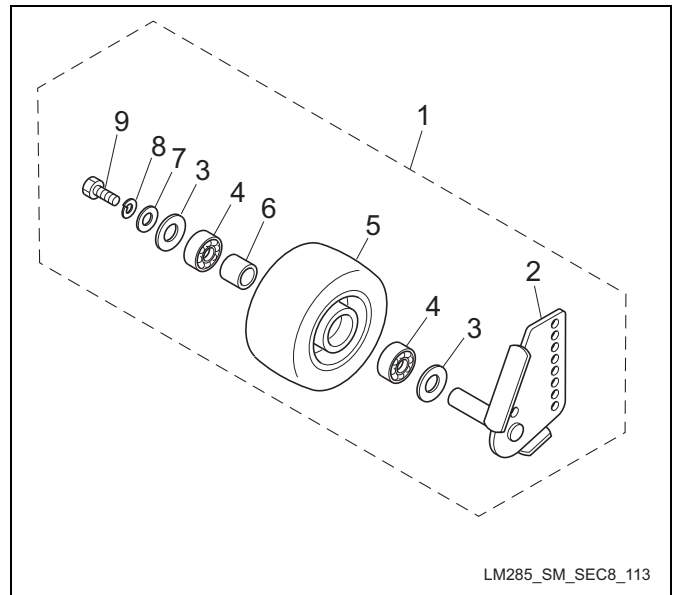

Figure: Work machine and mower unit-50-a

Work machine and mower unit

1	Front wheel right Ass'y
2	Roller bracket right
3	Washer
4	Bearing
5	Rubber wheel
6	Collar
7	Wheel clamping washer
8	S washer
9	Bolt

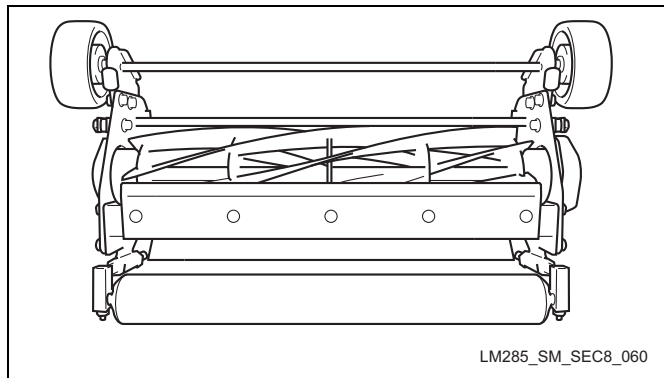

Figure: Work machine and mower unit-51-a

6. Rotate the wheel by hand and confirm the state of rotation.
7. Implement the adjustment of cutting height. (Refer to Owner's manual)
8. Install the mower unit. (Refer to "Installation of mower unit" (Page 8-5))

Rear roller Ass'y

Removal of rear roller Ass'y

⚠ Danger

The reel cutter and the bed knife are sharp blades. Exercise adequate care in handling to avoid cutting hands and/or feet.

1. Remove the mower unit and turn it back. (Refer to "Removal of mower unit" (Page 8-4))

2. Remove the nuts (2), the S washers (3) and the washers (4) of the right and left cutting height adjusting screws (1).

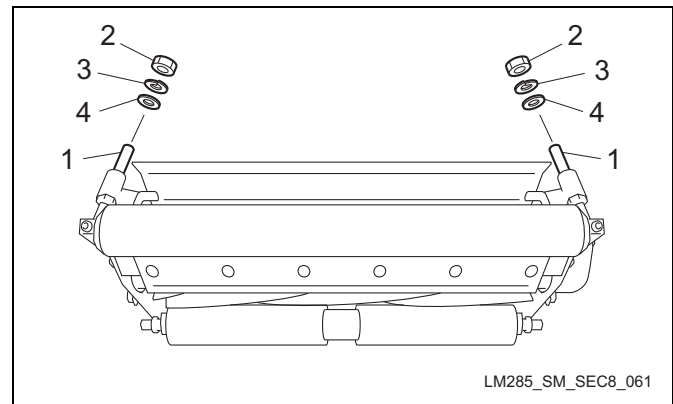

Figure: Work machine and mower unit-52-a

1	Cutting height adjusting screw
2	Nut
3	S washer
4	Washer

3. Lift up and draw out the rear roller (1) together with the cutting height adjusting screws (2) parallel to right and left to remove them from the mower unit.

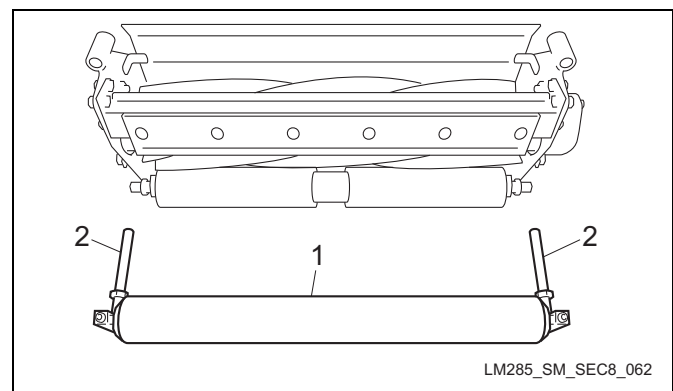

Figure: Work machine and mower unit-53-a

1	Rear roller
2	Cutting height adjusting screw

- Loosen the nuts (2) and the hollow set screws (3) fastening the right and left cutting height adjusting screws (1) and remove the cutting height adjusting screws (1).

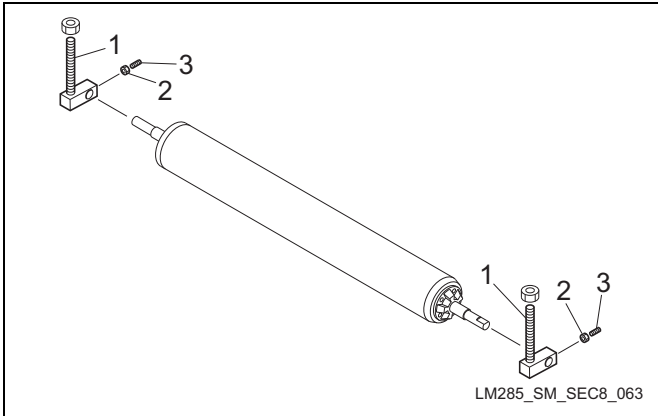

Figure: Work machine and mower unit-54-a

1	Cutting height adjusting screw
2	Nut
3	Hollow set screw

Installation of rear roller Ass'y

⚠ Danger

The reel cutter and the bed knife are sharp blades. Exercise adequate care in handling to avoid cutting hands and/or feet.

⚠ Caution

Refer to the tightening torques reference chart. We are not responsible for defects which occurred due to abnormal or overtorque tightening etc.

- Temporarily install the nuts (2), the hollow set screws (3) and the nuts (4) to the right and left cutting height adjusting screws (1) and insert and install the rear roller (5) to the mower unit.

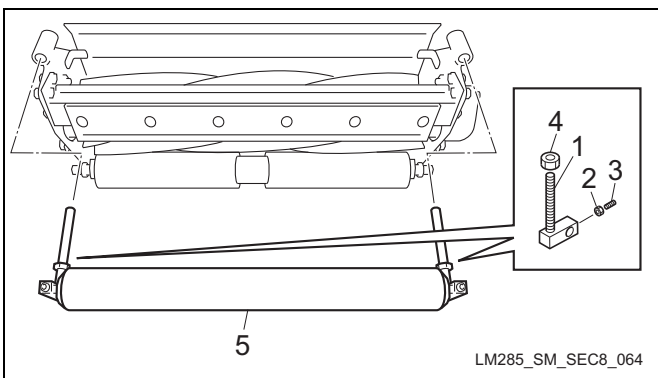

Figure: Work machine and mower unit-55-a

1	Cutting height adjusting screw
2	Nut
3	Hollow set screw
4	Nut
5	Rear roller

Important

Install the rear roller so that its shaft can project from the right and left cutting height adjusting screws by the same length.

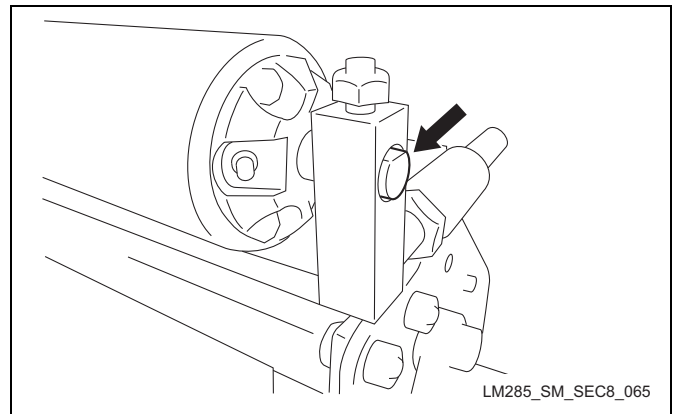

Figure: Work machine and mower unit-56-a

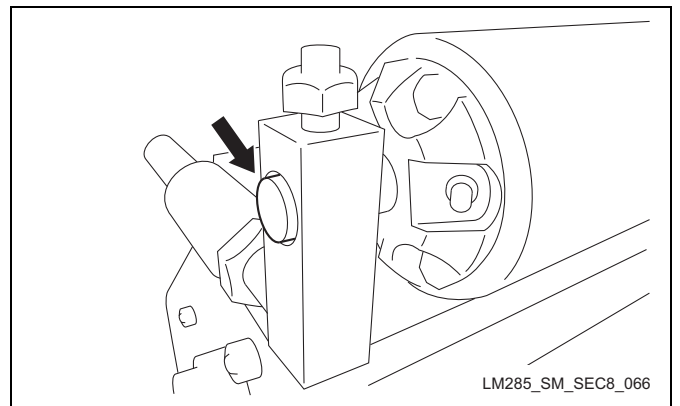

Figure: Work machine and mower unit-57-a

Work machine and mower unit

- Adjust the roller shaft so that the flat surface of one shaft end can fit the hollow set screw (1) of the cutting height adjusting screw and tighten the hollow set screw (1) and lock it with the nut (2).

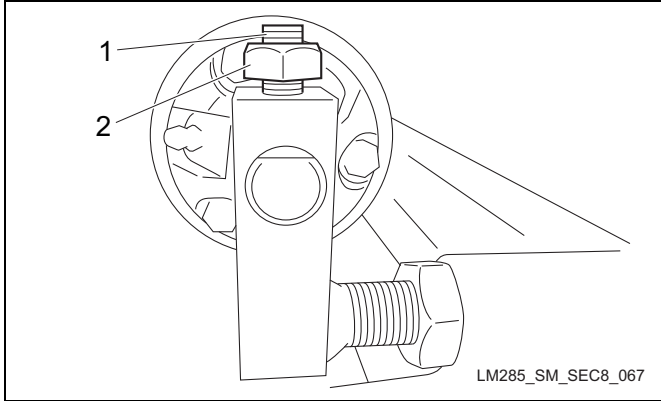

Figure: Work machine and mower unit-58-a

1	Hollow set screw
2	Nut

- Tighten and lock it on the other side.
- Install the nuts (2), the S washers (3) and the washers (4) of the right and left cutting height adjusting screws (1) and set them up according to desired cutting height. (Refer to Owner's manual)

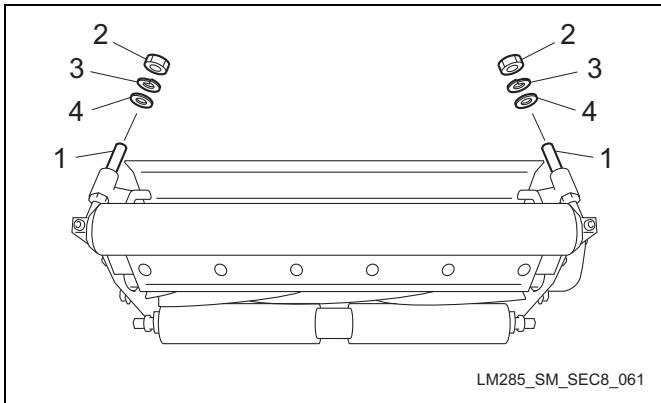

Figure: Work machine and mower unit-59-a

1	Cutting height adjusting screw
2	Nut
3	S washer
4	Washer

- Rotate the roller by hand and confirm the state of rotation.
- Implement the adjustment of cutting height. (Refer to Owner's manual)
- Install the mower unit. (Refer to "Installation of mower unit" (Page 8-5))

Reel cover

Removal of reel cover

! Danger

The reel cutter and the bed knife are sharp blades. Exercise adequate care in handling to avoid cutting hands and/or feet.

- Remove the mower unit. (Refer to "Removal of mower unit" (Page 8-4))
- Remove the bolts (3), the washers (4), the S washers (5) and the nuts (6) fastening the cover mounting plate (2) of the reel cover upper section to the mower frame (1).

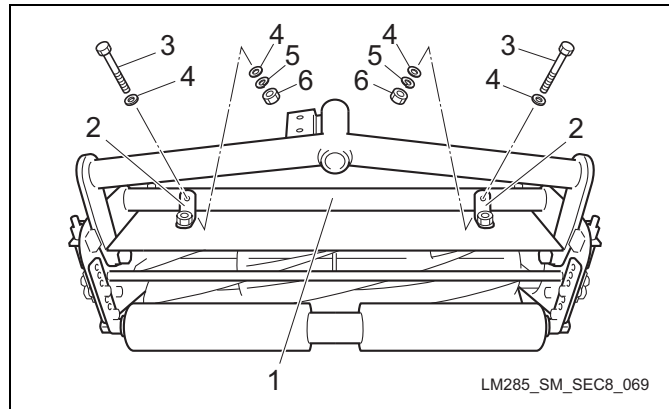

Figure: Work machine and mower unit-60-a

1	Mower frame
2	Cover mounting plate
3	Bolt
4	Washer
5	S washer
6	Nut

Work machine and mower unit

- Remove the bolts (4), the S washers (5) and the washers (6) fastening the right and left cover mounting plates (3) of the mower frame (2) to the reel cover (1).

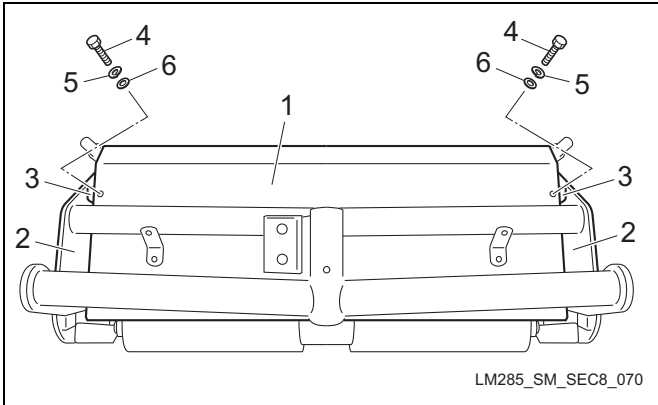

Figure: Work machine and mower unit-61-a

1	Reel cover
2	Mower frame
3	Cover mounting plate
4	Bolt
5	S washer
6	Washer

- Loosen the nuts (3) fastening the right and left cover mounting plates (2) of the mower frame (1) and turn the cover mounting plates (2) by 90 degrees.

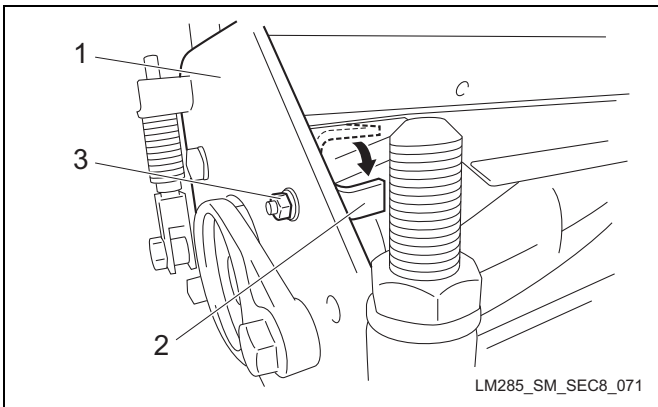

Figure: Work machine and mower unit-62-a

1	Mower frame
2	Cover mounting plate
3	Nut

- Draw out the reel cover (1) for the front direction and remove it.

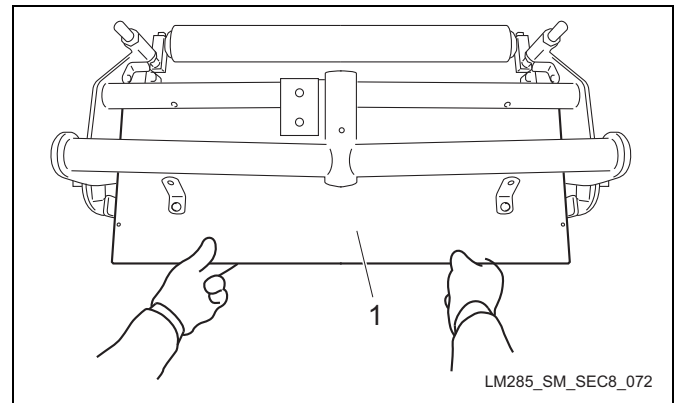

Figure: Work machine and mower unit-63-a

1	Reel cover
---	------------

Important

When removing the reel cover mounting plates, confirm the direction of installation.

- Remove the bolts (2), the washers (3), the S washers (4) and the nuts (5) fastening the reel cover mounting plates (1) and remove the reel cover mounting plates (1).

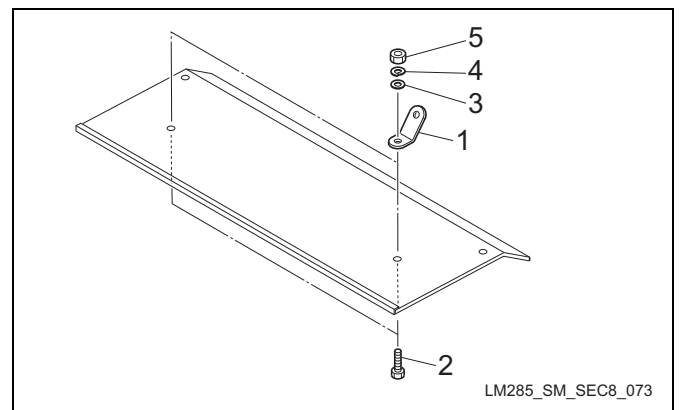

Figure: Work machine and mower unit-64-a

1	Reel cover mounting plate
2	Bolt
3	Washer
4	S washer
5	Nut

Work machine and mower unit

Installation of reel cover

Danger

The reel cutter and the bed knife are sharp blades. Exercise adequate care in handling to avoid cutting hands and/or feet.

Caution

Refer to the tightening torques reference chart. We are not responsible for defects which occurred due to abnormal or overtorque tightening etc.

Important

Exercise care in the direction of installing the reel cover mounting plates.

1. Temporarily install the reel cover mounting plates (1) with the bolts (2), the washers (3), the S washers (4) and the nuts (5).

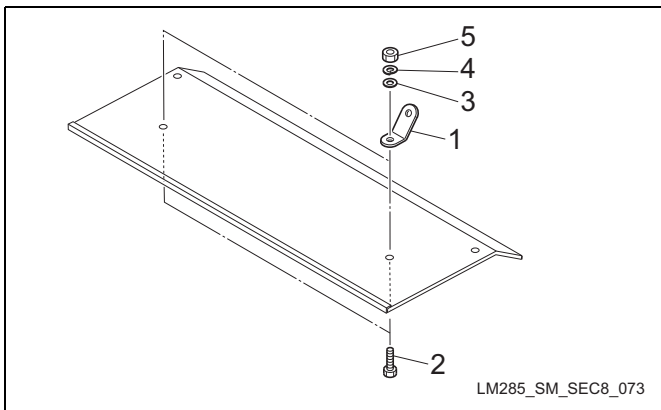

Figure: Work machine and mower unit-65-a

1	Reel cover mounting plate
2	Bolt
3	Washer
4	S washer
5	Nut

2. Insert the reel cover (3).

3. Turn the right and left cover mounting plates (2) of the mower frame by 90 degrees and position the reel cover (3) so that the bolt holes can fit each other.

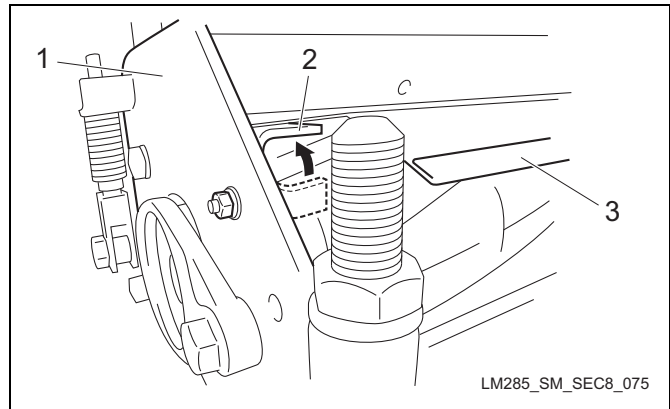

Figure: Work machine and mower unit-66-a

1	Mower frame
2	Cover mounting plate
3	Reel cover

4. Temporarily install the reel cover (1) to the right and left cover mounting plates (3) of the mower frame (2) with the bolts (4), the S washers (5) and the washers (6).

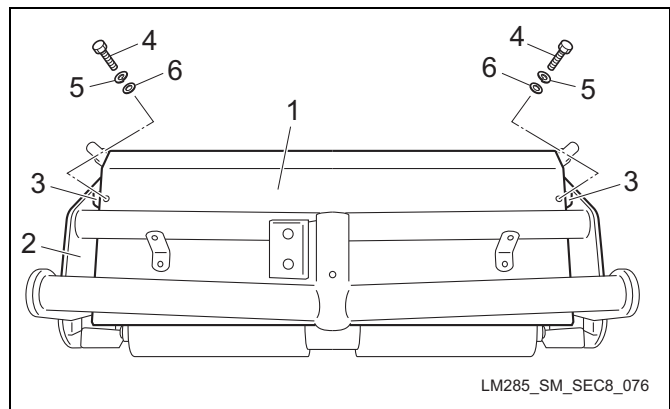

Figure: Work machine and mower unit-67-a

1	Reel cover
2	Mower frame
3	Cover mounting plate
4	Bolt
5	S washer
6	Washer

- Temporarily install the cover mounting plates (2) of the reel cover upper section to the mower frame (1) with the bolts (3), the washers (4), the S washers (5) and the nuts (6).

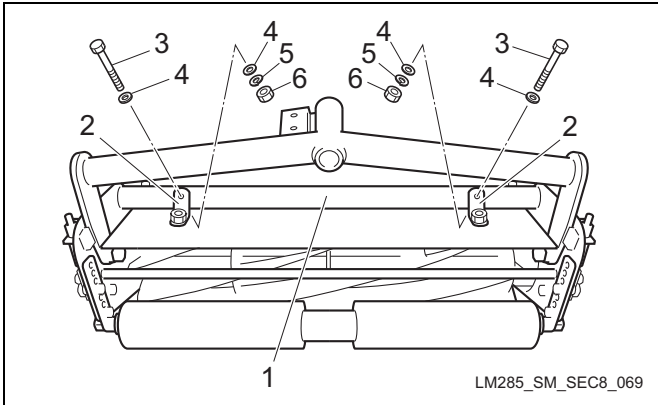

Figure: Work machine and mower unit-68-a

1	Mower frame
2	Cover mounting plate
3	Bolt
4	Washer
5	S washer
6	Nut

Important

Lift up the reel cover and tighten in the state that the cover is raised to the utmost level.

- Tighten the nuts (3) fastening the right and left cover mounting plates (2) of the mower frame to the mower frame (1).

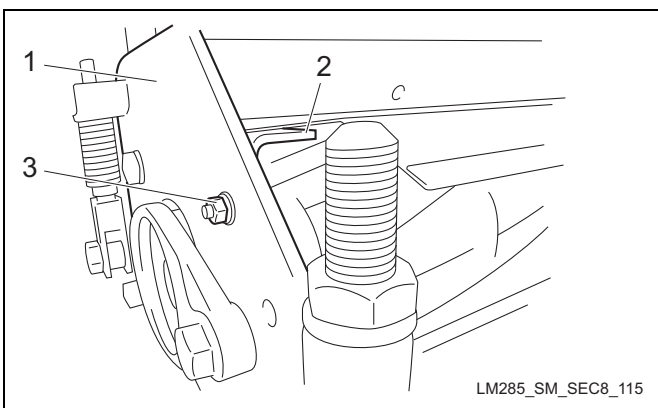

Figure: Work machine and mower unit-69-a

1	Mower frame
2	Cover mounting plate
3	Nut

- Tighten the bolts, the washers, the S washers and the nuts installed temporarily in the previous procedures Nos. 1, 4 and 5.

- Install the mower unit. (Refer to “Installation of mower unit” (Page 8-5))

Mower arm

Removal of mower arm

⚠ Danger

The reel cutter and the bed knife are sharp blades. Exercise adequate care in handling to avoid cutting hands and/or feet.

- Remove the mower unit. (Refer to “Removal of mower unit” (Page 8-4))
- Remove the reel cover. (Refer to “Removal of reel cover” (Page 8-20))

Important

When removing the frame bolts, lift up the mower arm and support it surely.

- Remove the frame bolts (1), the washers (2), the S washers (3) and the nuts (4) and remove the mower arm (5).

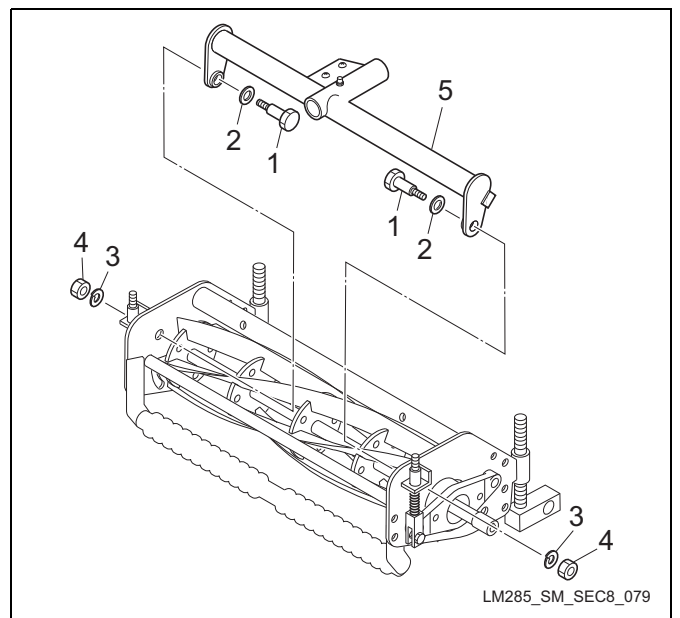

Figure: Work machine and mower unit-70-a

1	Frame bolt
2	Washer
3	S washer
4	Nut
5	Mower arm

Work machine and mower unit

Installation of mower arm

Danger

The reel cutter and the bed knife are sharp blades. Exercise adequate care in handling to avoid cutting hands and/or feet.

Caution

Refer to the tightening torques reference chart. We are not responsible for defects which occurred due to abnormal or overtorque tightening etc.

For installation, reverse the removal procedures.

Inspection and repair of each section

Reel cutter

A reel cutter may come to blunting due to frequency of use, nipping foreign materials during operation and damage during traveling. Inspect and grind or replace the reel cutter if needed.

Important

Make sure to replace the oil seal and the bearing with new ones.

- Confirm that the welds of the reel cutter and the disk does not come off.
- Confirm that the reel cutter does not break.
- Confirm that there is still a “relief” surface on the reel cutter.
- Confirm that there is no tempering on the reel cutter.
- Check the wear volume of the reel cutter.

For installation and removal, refer to “Removal of reel cutter” (Page 8-8) and “Installation of reel cutter” (Page 8-10).

Backlapping

Backlapping is like sharpening a kitchen knife. When the cutting edges of reel cutter and bedknife get rounder and blunt, apply pasty abrasive and reverse the reel cutter to sharpen the blades. However backlapping is as an emergency measure and so the work cannot recover the initial sharpness completely.

When the cutting edges of reel cutter and bedknife get rounder and blunt, implement backlapping according to the following procedures.

Caution

The reel cutter and the bed knife are sharp blades. Exercise adequate care in handling to avoid cutting hands and/or feet.

Caution

Do not implement backlapping by more than one person.

1. Prepare the strips of newspaper (1), the abrasive mixed with the lapping powder (2) and oil, or the gel compound (3) and the brush (4).

Work machine and mower unit

Reference: the mixture volume ratio of the abrasive is 1 lapping powder to 3to4 oil.

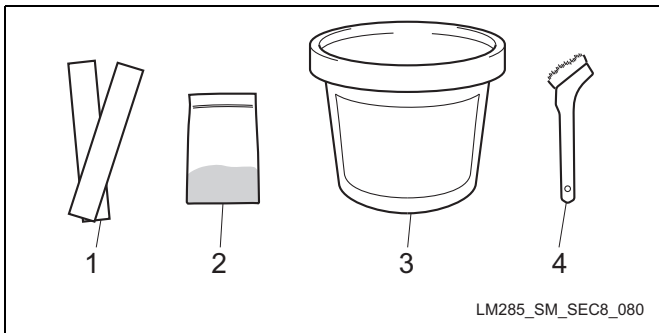

Figure: Work machine and mower unit-71-a

1	Newspaper
2	Lapping powder
3	Gel compound
4	Brush

! Danger

Never raise or lower the mower unit in the state of reversing the reel cutter.

2. Start the engine and raise the mower unit for backlapping up to the horizontal level and stop the engine and pull out the key.

! Caution

When checking the sharpness with the strips of newspaper, surely stop the engine and protect hands with gloves etc. Exercise great care to prevent the gloves etc. from getting entangled with the rotating reel cutter and to avoid cutting the hands and fingers.

Important

Inspect the sharpness in the state of blade engagement after mowing.

3. Insert two to three strips of newspaper (1) between the reel cutter (2) and the bedknife (3) at a right angle to the bedknife and rotate the reel cutter (2) from top down by hand and inspect the sharpness.

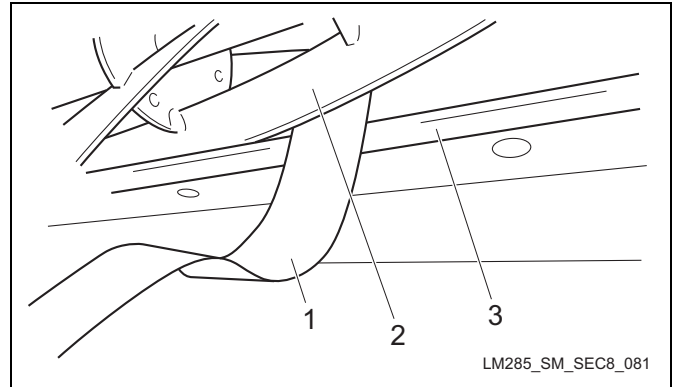

Figure: Work machine and mower unit-72-a

1	Newspaper
2	Reel cutter
3	Bedknife

4. Inspect sharpness of every cutting edge of the reel cutter (at three to four points of each blade).

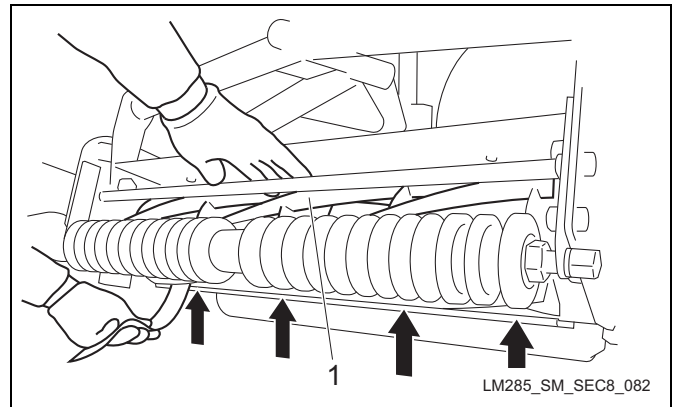

Figure: Work machine and mower unit-73-a

1	Reel cutter
---	-------------

5. While inspecting sharpness, mark the good points in sharpness with a chalk etc.

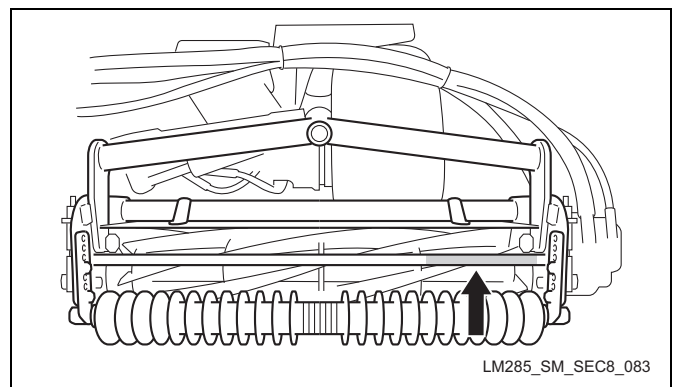

Figure: Work machine and mower unit-74-a

Work machine and mower unit

- Start the engine and lower the mower unit.
- Move the throttle lever (1) to slow down the engine rotation.

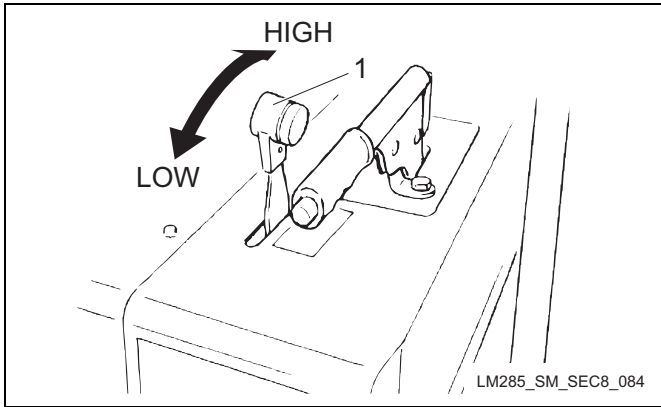

Figure: Work machine and mower unit-75-a

1	Throttle lever
---	----------------

- Loosen the knob (1) of reel negative rotation stopper and slide it to the position of "FOR BACKLAPPING."

Reference: This stopper is to prevent the reel from reversing during cutting operation.

- Shift the reel rotation lever (2) to the position of "REVERSE."

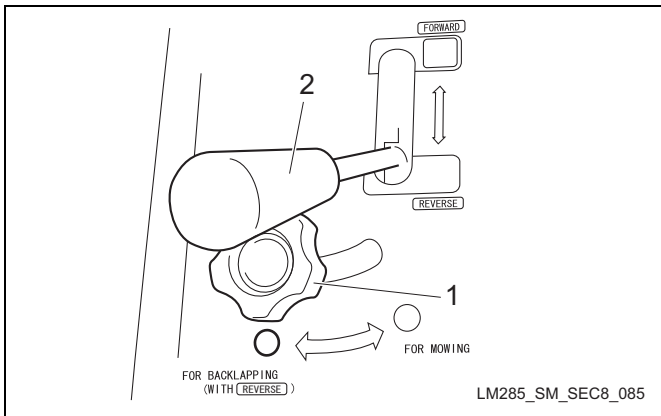

Figure: Work machine and mower unit-76-a

1	Reel negative rotation stopper
2	Reel rotation lever

Important

Shift the lever of only the mower unit scheduled for backlapping to Rotation side. The levers of the other mower units should be shifted to Stop side

- Shift the reel rotation/stop shift lever (2) on the gear motor (1) to Rotation side. Adjust proper reel rotation speed.

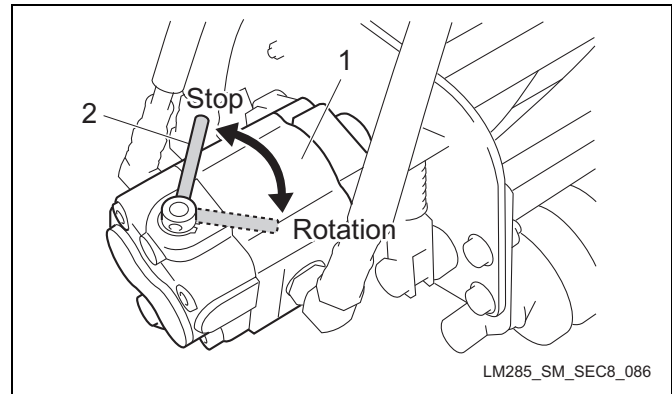

Figure: Work machine and mower unit-77-a

1	Gear motor
2	Reel rotation/stop shift lever

Danger

Due to rotation of the reel cutter, hands and feet may get entangled with it. When applying the abrasive, take great care to avoid entanglement.

Caution

Due to rotation of the reel cutter, the abrasive may scatter. Wear an eye protector etc. during the work.

Important

Do not apply the abrasive to the blunt portions. Apply it to the sharp portions. This work is to grind the sharp portions down to the level of the blunt portions which have a gap between the reel cutter and the bedknife so that the entire cutting edge can be sharpened uniformly.

- Put the abrasive on the brush (1) and apply it evenly on the upper surface of the chalk-marked, sharp portions of the reel cutter (2).

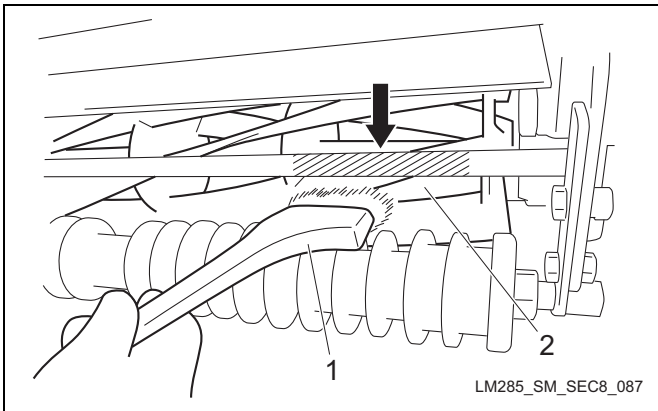

Figure: Work machine and mower unit-78-a

1	Brush
2	Reel cutter

- Shift the reel rotation/stop shift lever on the gear motor to Stop position and stop the engine. (See Figure: Work machine and mower unit-77-a)
- Wash out or wipe out the abrasive on the reel cutter with a cloth etc. and inspect the sharpness.
- Repeat the previous procedures Nos. 2 to 13 and implement backlapping so that the entire cutting edge of each blade of the reel cutter can be sharpened uniformly.
- Finally apply the abrasive to every cutting edge and implement the final backlapping.
- Stop the reel rotation and stop the engine and wash out the abrasive surely with a washer etc.

Important

Regarding the adjustment of blade engagement, adjust the reel cutter and the bedknife so that they can contact slightly.

- While checking the sharpness, implement the adjustment of blade engagement. (Refer to Owner's manual)

Grind

The purposes of the grind of reel cutter are to implement cylindrical grinding and to make the "relief" surface.

Implement the grind of reel cutter if the sharpness cannot be improved even after backlapping or if the "relief" surface is eliminated and so it takes longer time for backlapping since the contact area of the reel cutter and the bedknife increases.

Caution

The reel cutter and the bed knife are sharp blades. Exercise adequate care in handling to avoid cutting hands and/or feet.

Do not implement the grind work by more than one person.

For the grind, consult Baroness dealer

Bearing / Holder for the grinder

Use these for the grinder that uses bearings for centering alignment of reel cutter.

Important

Confirm the way of receiving the bearings surely since the way differs depending on the grinder.

- Use #6807 and #6204 bearings for both sides of the shaft and conform the outer diameter.

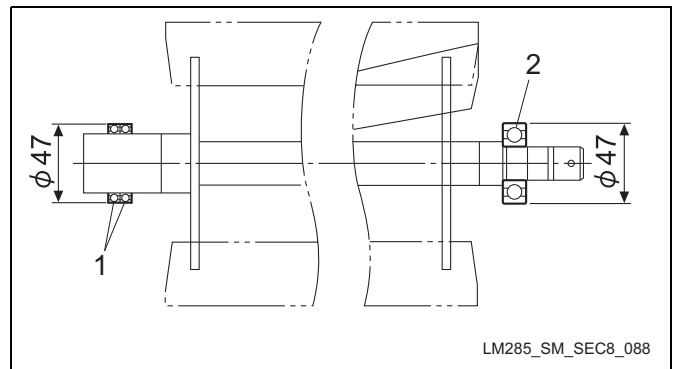

Figure: Work machine and mower unit-79-a

1	Bearing #6807
2	Bearing #6204

- Use the bearing holder for the hydraulic motor side of the shaft to conform the outer diameter with the bearing of the opposite side.

Bearing holder Ass'y dia.52mm (LM318—910320)

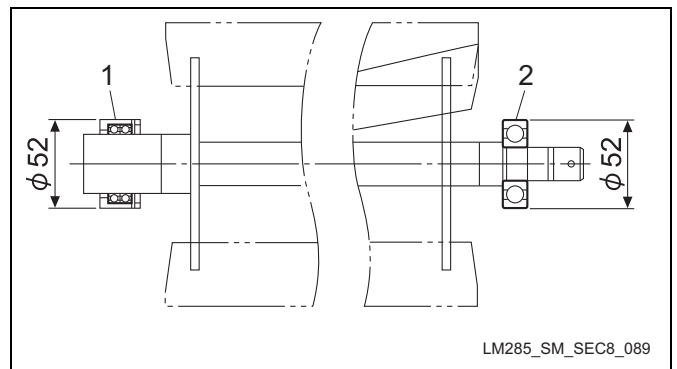

Figure: Work machine and mower unit-80-a

Work machine and mower unit

1	Holder Ass'y (dia.52mm)
2	Bearing #6304

Use the bearing holder for the hydraulic motor side of the shaft to conform the outer diameter with the bearing of the opposite side.

Bearing holder Ass'y dia.60mm (LM318—9104Z0)

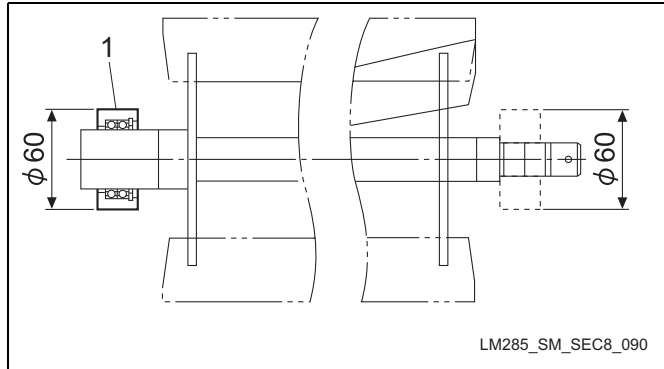

Figure: Work machine and mower unit-81-a

1	Holder Ass'y (dia.60mm)
---	-------------------------

Reel housing

The reel cutter may not rotate smoothly due to wear of the bearing depending on frequency of use or damage of the bearing etc. getting water. Inspect the reel housing and replace the oil seal and the bearing etc. with new ones if needed.

- Confirm that the reel housing has no crack.
- Confirm that the support shaft bolt and the insert portion of the housing bolt have no play.
- Confirm that the insert portion of the bearing has no play.

Caution

The reel cutter and the bed knife are sharp blades. Exercise adequate care in handling to avoid cutting hands and/or feet.

Caution

Refer to the tightening torques reference chart. We are not responsible for defects which occurred due to abnormal or overtorque tightening etc.

1. Remove the reel housing from the reel cutter. (Refer to "Removal of reel cutter" (Page 8-8))
2. Remove the three bolts (2) and S washers (3) of the reel housing (1).

Important

Remember the direction of the grease nipple (4) on the housing cover.

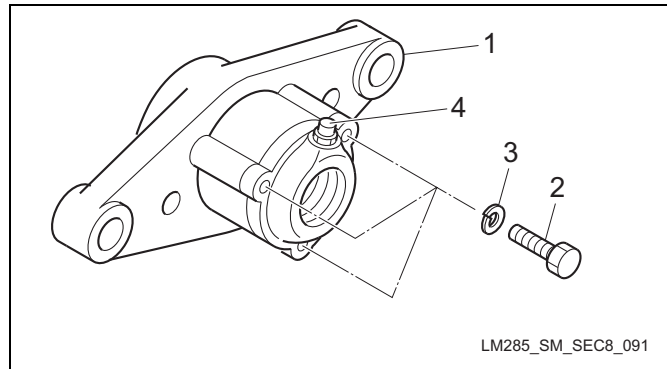

Figure: Work machine and mower unit-82-a

1	Reel housing
2	Bolt
3	S washer
4	Grease nipple

3. Remove the housing cover (1) and the packing (2).

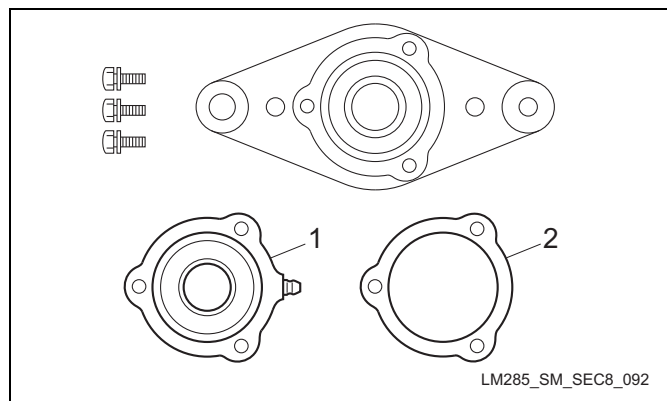

Figure: Work machine and mower unit-83-a

1	Housing cover
2	Packing

4. Remove the oil seal (1) of the housing cover.

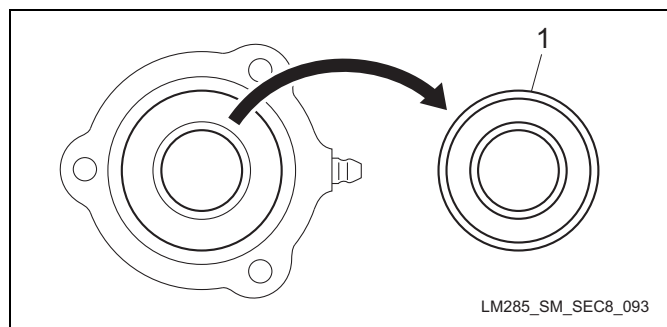

Figure: Work machine and mower unit-84-a

1	Oil seal
---	----------

- Remove the bearing (1) of the reel housing.

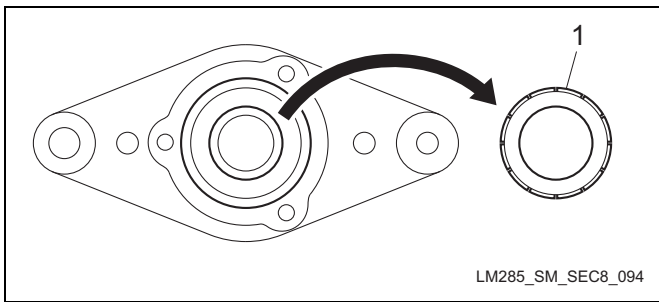

Figure: Work machine and mower unit-85-a

1	Bearing
---	---------

Important

Make sure to replace the bearing and the oil seal with new ones.

- Prepare the new bearing and oil seal and apply grease surely. Apply it surely to the inner surface of the oil seal.

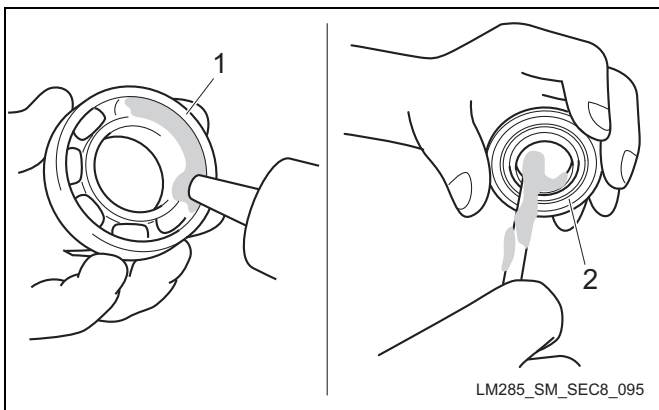

Figure: Work machine and mower unit-86-a

1	Ball bearing
2	Oil seal

- Hit in the bearing straight into the reel housing.
- Hit in the oil seal straight into the housing cover.

Reference: When hitting in the bearing and the oil seal, use 6005 bearing driver.

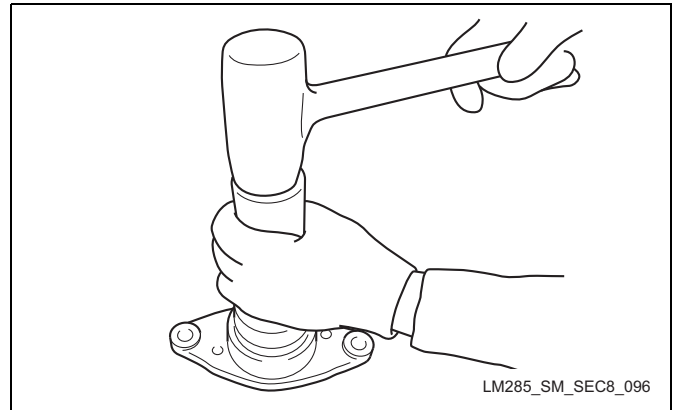

Figure: Work machine and mower unit-87-a

Important

Exercise care in the direction of the grease nipple on the housing cover.

- Install the packing and the housing cover to the reel housing with the three bolts and S washers. (See Figure: Work machine and mower unit-82-a)
- Install the reel housing. (Refer to “Installation of reel cutter” (Page 8-10))

Hydraulic motor housing

The reel cutter may not rotate smoothly due to wear of the bearing depending on frequency of use or damage of the bearing etc. getting water. Inspect the hydraulic motor housing and replace the oil seal and the bearing etc. with new ones if needed.

- Confirm that the hydraulic motor housing has no crack.
- Confirm that the support shaft bolt and the insert portion of the housing bolt have no play.
- Confirm that the insert portion of the bearing has no play.

⚠ Caution

The reel cutter and the bed knife are sharp blades. Exercise adequate care in handling to avoid cutting hands and/or feet.

⚠ Caution

Refer to the tightening torques reference chart. We are not responsible for defects which occurred due to abnormal or overtorque tightening etc.

Work machine and mower unit

1. Remove the hydraulic motor housing (1) from the reel cutter. (Refer to “Removal of reel cutter” (Page 8-8))
2. Remove the stop ring (2), the oil seal (3) and the bearing (4) in order.

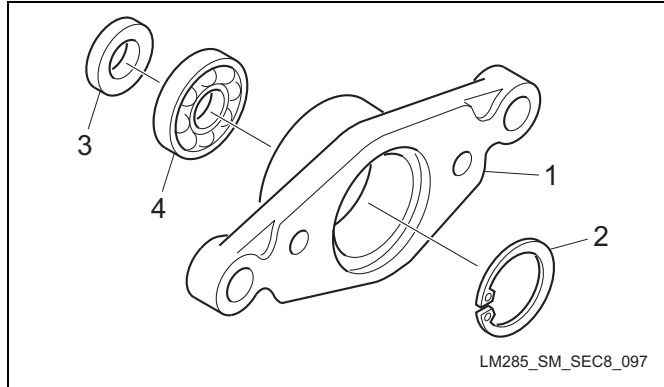

Figure: Work machine and mower unit-88-a

1	Hydraulic motor housing
2	Stop ring
3	Oil seal
4	Bearing

Important

Make sure to replace the bearing and the oil seal with new ones.

3. Prepare the new bearing and oil seal and apply grease surely. Apply it surely to the inner surface of the oil seal.

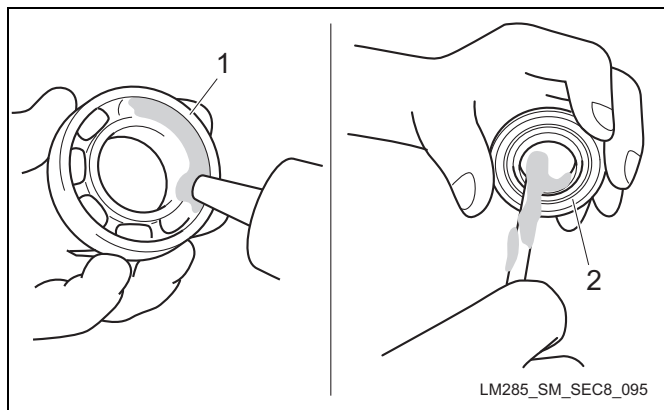

Figure: Work machine and mower unit-89-a

1	Ball bearing
2	Oil seal

Important

Exercise care in the direction of the stop ring.

4. Hit in the bearing straight into the hydraulic motor housing and install the stop ring. (See Figure: Work machine and mower unit-88-a)

Reference: When hitting in the bearing, use 6207 bearing driver.

5. Hit in the oil seal straight into the hydraulic motor housing. (See Figure: Work machine and mower unit-87-a)

Reference: When hitting in the oil seal, use 6207 bearing driver.

6. Install the hydraulic motor housing. (Refer to “Installation of reel cutter” (Page 8-10))

Bedknife

The bedknife may get chipped or blunt due to frequency of use, getting sands during operation and damage during traveling etc. Inspect the bedknife and replace the bedknife and the bedknife mount base with new ones if needed.

- Confirm that the cutting edge of the bedknife does not get round and/or wave.
- Replace the bedknife if the wearing volume is large.

Caution

The reel cutter and the bed knife are sharp blades. Exercise adequate care in handling to avoid cutting hands and/or feet.

Caution

Refer to the tightening torques reference chart. We are not responsible for defects which occurred due to abnormal or overtorque tightening etc.

1. Remove the bedknife mount base Ass’y. (Refer to “Removal of bed knife mount base Ass’y” (Page 8-5))

Caution

Work while putting the bedknife mount base Ass’y on the stable working table.

- Loosen the screws (1) and remove the bedknife (3) from the bedknife mount base (2).

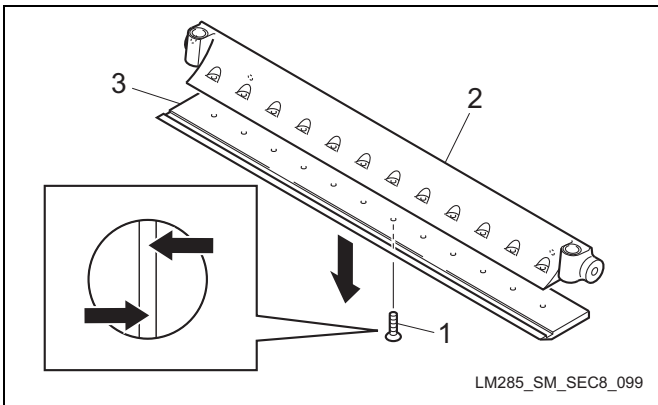

Figure: Work machine and mower unit-90-a

1	Screw
2	Bedknife mount base
3	Bedknife

- Scour the rust etc. off and clean the bedknife mount surface of the bedknife mount base with care to avoid damaging the surface.

Important

Make sure to replace the screws for installation with new ones.

- Install the new bedknife (3) to the bedknife mount base (2) with the screws (1) in order from the center to the right and left.

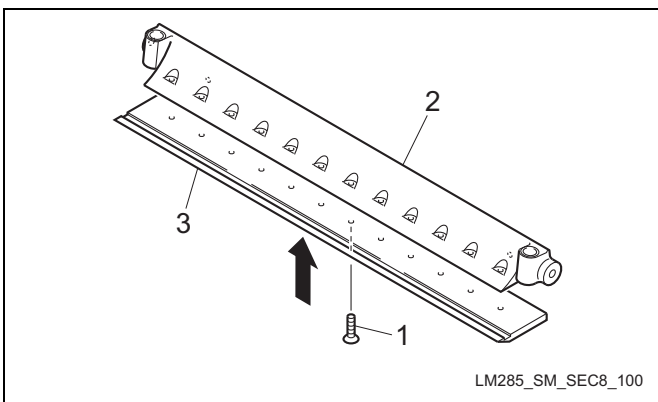

Figure: Work machine and mower unit-91-a

1	Screw
2	Bedknife mount base
3	Bedknife

Reference: Order of the screws installation

First tighten the screw at the center and then at the immediate right from the center and then at the immediate left from the center and

afterward in alternate shifts for both of the outer ends.

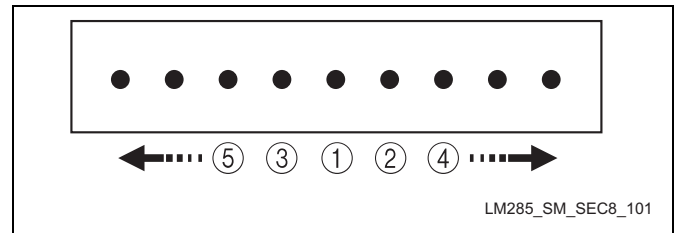

Figure: Work machine and mower unit-92-a

- Install the bedknife mount base Ass'y. (Refer to "Installation of bed knife mount base Ass'y" (Page 8-6))

Front roller

The front roller may not rotate smoothly due to wear of the bearing depending on frequency of use or damage of the bearing etc. getting water. Inspect the front roller and replace the oil seal and the bearing etc. with new ones if needed.

- Confirm that there is no play on the fitting of the roller pipe and the housing.
- Confirm that there is no wear and/or fixation on the roller.
- Confirm that there is no wear on the collars and the nuts etc. on the both ends.
- Confirm that there is no wear and/or rust on the bearing and that there is no play on the housing and the bearing.

Caution

The reel cutter and the bed knife are sharp blades. Exercise adequate care in handling to avoid cutting hands and/or feet.

Caution

Refer to the tightening torques reference chart. We are not responsible for defects which occurred due to abnormal or overtorque tightening etc.

- Remove the front roller Ass'y. (Refer to "Removal of front roller Ass'y" (Page 8-14))
- Remove the hollow set screw (1) and the nut (2) from one side and remove the roller housing (3).

Work machine and mower unit

- Remove the stop ring (4) from the other side and remove the collar stopper (5), the collar (6) and the O ring (7) and then remove the roller housing (8).

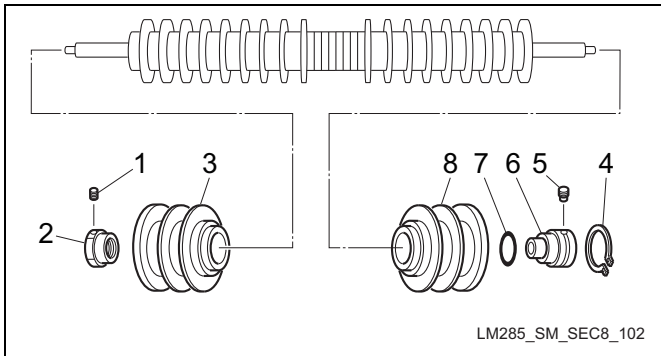

Figure: Work machine and mower unit-93-a

1	Hollow set screw
2	Nut
3	Roller housing
4	Stop ring
5	Collar stopper
6	Collar
7	O ring
8	Roller housing

- Remove the rollers (1), the washers (2), the springs (3) and the collars (4) and draw out the roller pipe (5) and the roller shaft (6).

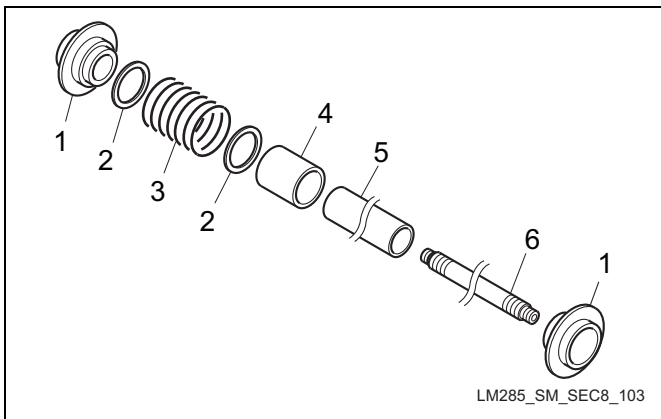

Figure: Work machine and mower unit-94-a

1	Roller
2	Washer
3	Spring
4	Collar
5	Roller pipe
6	Roller shaft

- Remove the stop rings (2), the oil seals (3), the collars (4), the bearings (5), the oil seals (6) and the seal housings (7) in the right and left roller housings (1).

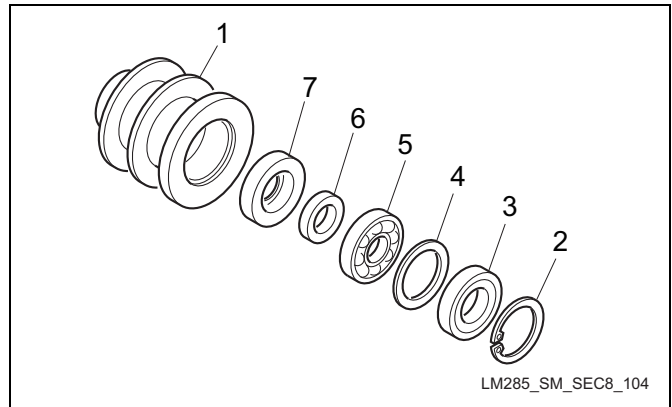

Figure: Work machine and mower unit-95-a

1	Roller housing
2	Stop ring
3	Oil seal
4	Collar
5	Bearing
6	Oil seal
7	Seal housing

Important

Make sure to replace the bearing, the oil seal and the O ring with new ones.

- Prepare the new bearing and oil seal and apply grease surely. Apply it to the bearing as rubbing the bearing with it to the extent that grease may spill from the opposite side. Apply it surely to the inner surface of the oil seal.

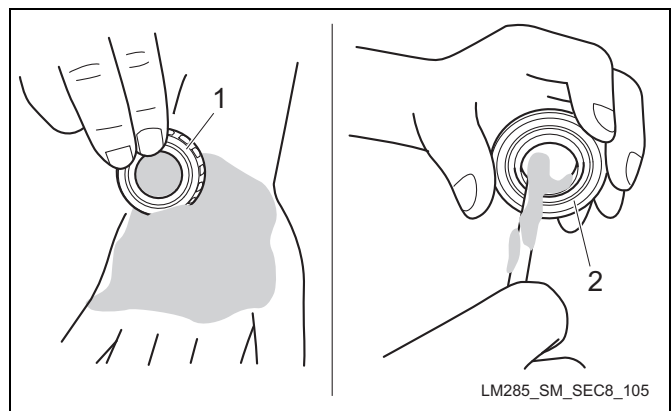

Figure: Work machine and mower unit-96-a

1	Tapered roller bearing
2	Oil seal

- Install the front roller Ass'y by the reverse procedures to the procedures Nos.2 to 6.

Reference: When hitting in the oil seal and the bearing, use 34 oil seal driver and 6005 bearing driver.

8. Fix the roller shaft and adjust and tighten the nut (1) so that the roller can rotate lightly without rattling.

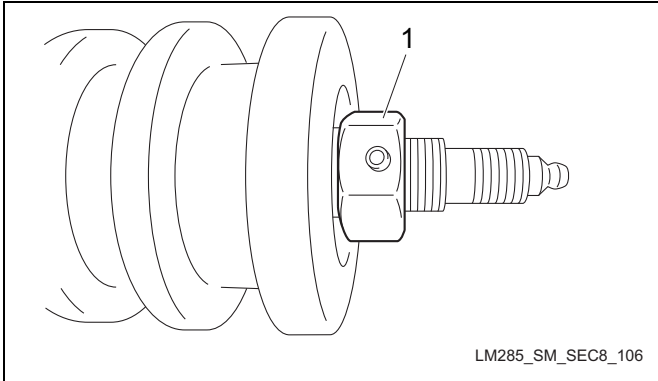

Figure: Work machine and mower unit-97-a

1	Nut
---	-----

9. Confirm that the roller has no play.
10. Inject grease. (Refer to “Grease point” (Page 3-11))
11. Install the front roller Ass’y. (Refer to “Installation of front roller Ass’y” (Page 8-14))

Front wheel

The front wheel may not rotate smoothly due to wear of the bearing depending on frequency of use or damage of the bearing etc. getting water. Inspect the front wheel and replace the oil seal and the bearing etc. with new ones if needed.

- Confirm that there is no play on the fitting of the wheel and the bearing and on the fitting of the bearing and the bracket.
- Confirm that there is no wear on the rubber of the wheel.

Important

Make sure to replace the bearings with new ones.

For assembly and disassembly, refer to “Removal of front wheel Ass’y” (Page 8-15) and “Installation of front wheel Ass’y” (Page 8-16).

Rear roller

The rear roller may not rotate smoothly due to wear of the bearing depending on frequency of use or damage of the bearing etc. getting water. Inspect the rear roller and replace the oil seal and the bearing etc. with new ones if needed.

- Confirm that there is no play on the fitting of the roller pipe and the housing.
- Confirm that there is no wear and/or fixation on the roller.
- Confirm that there is no wear on the roller shaft.
- Confirm that there is no wear and/or rust on the bearing.
- Confirm that there is no play on the fitting of the housing and the bearing.

Caution

The reel cutter and the bed knife are sharp blades. Exercise adequate care in handling to avoid cutting hands and/or feet.

Caution

Refer to the tightening torques reference chart. We are not responsible for defects which occurred due to abnormal or overtorque tightening etc.

1. Remove the rear roller Ass’y. (Refer to “Removal of rear roller Ass’y” (Page 8-18))
2. Remove the three bolts (1) and washers (2) fastening the seal housing.

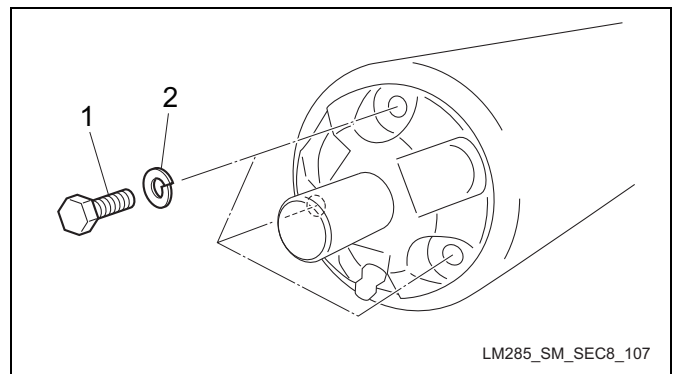

Figure: Work machine and mower unit-98-a

1	Bolt
2	S washer

Work machine and mower unit

- Hit the one end of the roller shaft (1) with a plastic hammer (2) to push out the shaft.

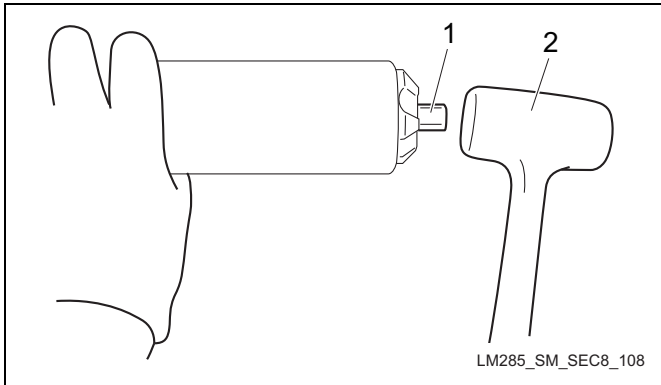

Figure: Work machine and mower unit-99-a

1	Roller shaft
2	Plastic hammer

- Remove the seal housing (1), the packing (2) and the bearing (3) from one end.
- Remove the oil seal (4) from the seal housing.
- Remove the same parts as above mentioned from the opposite end.
- Remove the roller shaft (5).

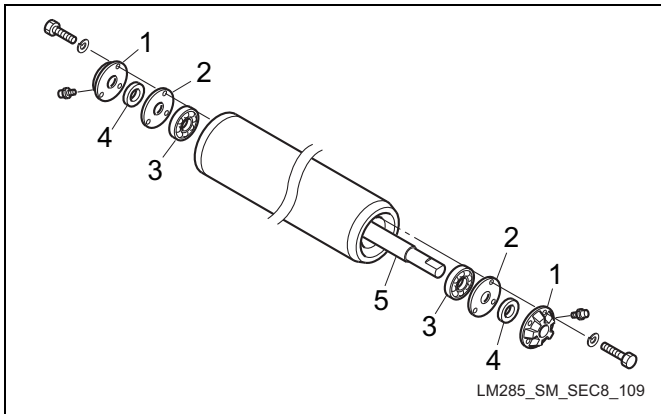

Figure: Work machine and mower unit-100-a

1	Seal housing
2	Packing
3	Bearing
4	Oil seal
5	Roller shaft

Important

Make sure to replace the bearings, the oil seals and the O rings with new ones.

- Prepare the new bearing and oil seal and apply grease surely. Apply it surely to the inner surface of the oil seal.

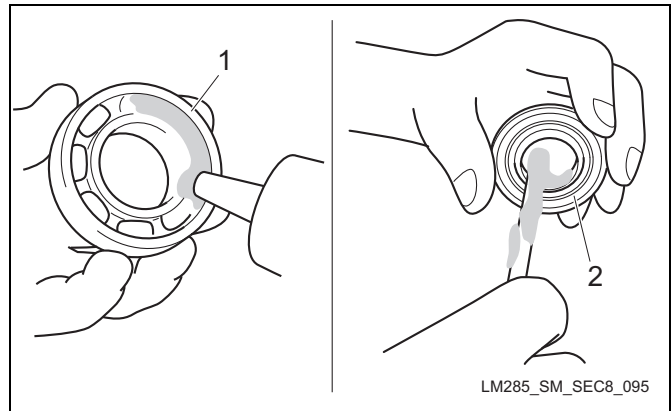

Figure: Work machine and mower unit-101-a

1	Ball bearing
2	Oil seal

- Install the rear roller Ass'y by the reverse procedures to procedures Nos.2 to 7.
- Fix the roller shaft and confirm that the roller can rotate smoothly.
- Inject grease. (Refer to "Grease point" (Page 3-11))
- Install the rear roller Ass'y. (Refer to "Installation of rear roller Ass'y" (Page 8-19))

Reel cover

The reel cover may get entangled in the reel cutter due to corrosion and/or damage during operation and traveling depending on frequency of use. Inspect the reel cover and replace the parts if needed.

- Confirm that the safety decals are not unglued.
- Confirm that there is no crack and no change of shape etc.

For installation and removal, refer to "Removal of reel cover" (Page 8-20) and "Installation of reel cover" (Page 8-22).

Mower arm

Decreased mowing quality or difficulty of mowing may occur due to damage like change of shape during operation and traveling depending on frequency of use. Inspect the mower arm and replace the parts if needed.

- Confirm that there is no play on the bush inside the mower arm.
- Check the state of tightening on the fitting section with the mower frame.

- confirm that there is no change of shape etc. on the mower arm.

For installation and removal, refer to “Removal of mower arm” (Page 8-23) and “Installation of mower arm” (Page 8-24).

Work machine and mower unit

Engine problems	9-2
Travelling problems	9-3
Steering problems	9-4
Work machine and mower unit problems	9-5

Troubleshooting

Engine problems

Problem	Cause	Reference
The engine does not start. (The starter motor does not rotate.)	The interlock system has been activated. (The seat is not occupied. The parking brake is not pulled. The reel rotation lever is not in neutral.)	"Interlock system" (Page 6-7)
	A component in the interlock system has failed. (Seat switch, parking brake switch, reel rotation switch)	"Electrical components" (Page 6-11)
	Over discharge or failure of the battery.	"Battery" (Page 6-6)
	A battery cable has been disconnected.	"Battery" (Page 6-19)
	A starter circuit wire has been disconnected or broken.	
	The fusible link is cut.	"Fusible link" (Page 6-17)
	Conduction loss of the key switch, the coupler, the wiring etc.	"Key switch" (Page 6-14)
	Defect of grounding the negative electrode.	
	Defect of the starter relay.	"Starter relay" (Page 6-16)
	Failure of the starter motor.	Engine maintenance manual
The engine does not start. (The starter motor rotates.)	Adhesion or breakage of the engine rotation parts.	Engine maintenance manual
	The interlock system has been activated. (The traveling pedal is not in neutral.)	"Interlock system" (Page 6-7)
	The battery level is low.	"Battery" (Page 6-6)
	Defect of grounding the negative electrode.	
	Failure of the key switch	"Key switch" (Page 6-14)
	Short circuit of the stop switch wiring	"Key switch" (Page 6-14)
	The fuel tank is empty.	Engine handling manual
	The fuel filter cock is not open.	Engine handling manual
	The fuel filter is clogged.	Engine handling manual
	Failure of the fuel pump.	Engine maintenance manual
	Failure of the fuel stop solenoid.	Engine maintenance manual
	Wrong fuel is used.	Engine handling manual
	The air cleaner element is clogged.	"Air cleaner" (Page 4-5)
Defect of the engine	Engine maintenance manual	
The engine starts but stops immediately.	Interlock system has been activated. (leaving the seat without pulling the parking brake. The reel rotation lever is shifted to ON.)	"Interlock system" (Page 6-7)
	A component in the interlock system has failed. (Seat switch)	"Seat switch" (Page 6-12)
	The fuel level is low.	Engine handling manual
	The fuel filter is clogged.	Engine handling manual
	The fuel filter cock is not open.	Engine handling manual
	The air cleaner element is clogged.	"Air cleaner" (Page 4-5)
	The engine speed is low.	

Problem	Cause	Reference
The battery cannot be charged.	A battery cable is loose.	"Battery" (Page 6-19)
	A battery terminal has corroded.	"Battery" (Page 6-19)
	An electrolyte is short.	"Battery" (Page 6-19)
	Failure of the battery	"Battery" (Page 6-6)
	The fan belt is loose.	Engine handling manual
	A charging circuit wire has been disconnected or broken.	
	Current surge to accessories	
	Defect of the alternator or regulator	Engine maintenance manual

Travelling problems

Problem	Cause	Reference
The machine does not have power to travel.	The engine speed is low.	
	Malfunction of the engine	Engine maintenance manual
	The parking brake is applied.	"Brake wire, rod" (Page 7-24)
	The movement of the traveling pump shift lever is small.	"Traveling cable, Rod" (Page 7-25)
	The unload valve is not completely closed.	Owner's operating manual of the vehicle
	The hydraulic oil level is low.	"Hydraulic oil" (Page 5-40)
	The hydraulic oil line filter is clogged.	"Hydraulic oil filter" (Page 5-43)
	The hydraulic oil suction filter is clogged.	"Hydraulic oil filter" (Page 5-43)
	The hydraulic oil is too cold.	Owner's operating manual of the vehicle
	Contamination of the hydraulic oil (contaminated by dust, water or air)	"Hydraulic oil" (Page 5-40)
	The viscosity of the hydraulic oil is incorrect.	"Hydraulic oil" (Page 5-40)
	The hydraulic oil cooler does not cool the oil sufficiently.	Owner's operating manual of the vehicle
	Failure of the charge pump	"Charge circuit" (Page 5-36)
	Failure of the piston pump	"Traveling circuit" (Page 5-13)
Failure of the traveling motor	"Wheel motor" (Page 5-60)	
The machine does not travel. (Other than the above-mentioned causes)	Defect of the rod to the traveling pump	"Traveling cable, Rod" (Page 7-25)
	The traveling pump shift lever does not operate.	"Traveling cable, Rod" (Page 7-25)
	The unload valve is open.	Owner's operating manual of the vehicle

Troubleshooting

Problem	Cause	Reference
The machine travels without depressing the traveling pedal.	The traveling pedal does not move smoothly.	"Traveling cable, Rod" (Page 7-25)
	The traveling pump is not in neutral.	"Traveling cable, Rod" (Page 7-25)
The brake cannot be applied.	The brake wire is cut or extended.	"Brake wire, rod" (Page 7-24)
	Defect or wear of the brake shoe, drum etc.	"Brake" (Page 7-23)
	Attachment of water, dust or oil to the brake section (brake shoe, drum)	"Brake" (Page 7-23)
	Big backlash of the brake pedal	"Brake wire, rod" (Page 7-24)

Steering problems

Problem	Cause	Reference
The steering wheel is difficult to turn.	The engine speed is low.	
	The tire pressure is low.	"Tire" (Page 7-22)
	Shortage of grease in the king pin.	"Grease point" (Page 3-11)
	The hydraulic oil level is low.	"Hydraulic oil" (Page 5-40)
	The hydraulic oil is too cold.	Owner's operating manual of the vehicle
	Contamination of the hydraulic oil (contaminated by dust, water or air)	"Hydraulic oil" (Page 5-40)
	The viscosity of the hydraulic oil is incorrect.	"Hydraulic oil" (Page 5-40)
	The hydraulic oil cooler does not cool the oil sufficiently.	Owner's operating manual of the vehicle
	The hydraulic oil line filter is clogged.	"Hydraulic oil filter" (Page 5-43)
	The hydraulic oil suction filter is clogged.	"Hydraulic oil filter" (Page 5-43)
	Failure of the steering cylinder	"Steering cylinder" (Page 5-57)
	Failure of Orbitrol	"Steering circuit" (Page 5-34)
Failure of the work pump	"Piston pump" (Page 5-44)	

Work machine and mower unit problems

Problem	Cause	Reference
The work machine cannot be raised or lowered.	Dropping off of the pin for raise/lower cylinder.	"Raise/lower cylinder" (Page 5-51)
	Failure of the raise/lower lever.	"4-block valve" (Page 5-48)
	Shortage of grease in the lift arm fulcrum section.	"Grease point" (Page 3-11)
	The stop valve is shifted to STOP side.	Owner's operating manual of the vehicle
	Locked by use of the mower lock.	Owner's operating manual of the vehicle
	The hydraulic oil level is low.	"Hydraulic oil" (Page 5-40)
	The hydraulic oil is too cold.	Owner's operating manual of the vehicle
	Contamination of the hydraulic oil (contaminated by dust, water or air)	"Hydraulic oil" (Page 5-40)
	The viscosity of the hydraulic oil is incorrect.	"Hydraulic oil" (Page 5-40)
	The hydraulic oil cooler does not cool the oil sufficiently.	Owner's operating manual of the vehicle
	The hydraulic oil line filter is clogged.	"Hydraulic oil filter" (Page 5-43)
	The hydraulic oil suction filter is clogged.	"Hydraulic oil filter" (Page 5-43)
	Failure of the 4-block valve	"Raising/lowering circuit" (Page 5-32)
	Failure of the raise/lower cylinder	"Raise/lower cylinder" (Page 5-51)
Failure of the work pump	"Reel rotation circuit" (Page 5-38)	
The work machine falls quickly.	Failure of the raise/lower cylinder	"Raise/lower cylinder" (Page 5-51)
	Not locked by use of the mower lock.	Owner's operating manual of the vehicle
	The stop valve is not shifted to STOP side.	Owner's operating manual of the vehicle
	Failure of the 4-block valve	"4-block valve" (Page 5-48)

Troubleshooting

Problem	Cause	Reference
Weak reel rotation	Reel blade engagement, Invasion by a foreign substance.	Owner's operating manual of the vehicle
	The reel motor lever tilts toward the reel stop position.	Owner's operating manual of the vehicle
	Maladjustment of the selector valve cam	"Selector valve" (Page 5-44)
	The hydraulic oil level is low.	"Hydraulic oil" (Page 5-42)
	The hydraulic oil is too cold.	Owner's operating manual of the vehicle
	Contamination of the hydraulic oil (contaminated by dust, water or air)	"Hydraulic oil" (Page 5-42)
	The viscosity of the hydraulic oil is incorrect.	"Hydraulic oil" (Page 5-42)
	The hydraulic oil cooler does not cool the oil sufficiently.	Owner's operating manual of the vehicle
	The hydraulic oil line filter is clogged.	"Hydraulic oil filter" (Page 5-43)
	The hydraulic oil suction filter is clogged.	"Hydraulic oil filter" (Page 5-43)
	Failure of the reel motor	"Gear motor" (Page 5-50)
	Failure of the relief valve	"Reel rotation circuit" (Page 5-19)
	Failure of the manifold with solenoid valve	"Solenoid valve" (Page 6-14)
	Failure of the work pump	"Piston pump" (Page 5-44)
Failure of the 4-block valve	"4-block valve" (Page 5-48)	
The reel does not rotate. (Other than the above-mentioned causes)	The work machine is not lowered.	Owner's operating manual of the vehicle
	The reel rotation lever is not shifted to Rotation.	Owner's operating manual of the vehicle
	Failure of the reel rotation lever	"4-block valve" (Page 5-48)
	The reel motor lever is shifted to the reel stop position.	Owner's operating manual of the vehicle
	Maladjustment or failure of the proximity switch	"Proximity switch" (Page 6-11)
Bad finish after work	Disengagement of the blade	Owner's operating manual of the vehicle
	The mowing speed is too fast.	Owner's operating manual of the vehicle
	Blunt reel and/or bedknife	Owner's operating manual of the vehicle
	The engine speed is low.	Owner's operating manual of the vehicle

Specifications	10-2
Maintenance schedule	10-3
Hydraulic circuit diagram	10-5
Electrical circuit diagram	10-6
Electrical wiring diagram	10-7
Consumable parts list	10-8

Reference

Specifications

LM285

Main unit	Total length	Wheel type : 276cm (108.66 in.) / Roller type : 265cm (104.33 in.)
	Total width	Traveling : 234.0cm (92.13 in.) / Operating : 303.0cm (119.29 in.)
	Total height	183cm (72.05 in.)
	Wheelbase	136.7cm (53.82 in.)
	Tread	Front wheel : 137cm (53.94 in.) / Rear wheel : 130.8cm (51.50 in.)
	Gross mass	Traveling : 1,230kg (2,709.25 lb.) / Operating : 902kg (1,986.78 lb.)
	Drive system	HST Full-time 4WD
	Traveling speed	Forward : 14.4km/h (8.95mph) / Reverse : 8.5km/h (5.28mph)
	Steering	Power steering (Orbitrol plus Hydraulic cylinder)
	Brake	Internal expanding mechanical brake (Front two wheels)
Tire size: Air pressure	Rough Front wheel	23x10.50-12 4P : 120kPa (1.22kgf/cm ²) (17.40psi)
	Rough Rear wheel	23x8.50-12 4P : 150kPa (1.53kgf/cm ²) (21.76psi)
	Optional Front wheel	24x13.00-12 4P : 120kPa (1.22kgf/cm ²) (17.40psi)
	Optional Rear wheel	23x8.50-12 4P : 150kPa (1.53kgf/cm ²) (21.76psi)
Work machine (Mower unit)	Reel cutter	Width : 66.0cm (25.98 in.) / Diameter : 16.3cm (6.42 in.)/5-,7-, or 9-blade
	Cutting height	Wheel type : 1.1 – 6.8cm (0.43 – 2.68 in.) Roller type : 1.0 – 6.0cm (0.39 – 2.36 in.)
	Cutting width : Mowing by 3 units	172.9cm (68.07 in.)
	Cutting width : Mowing by 4 units	227.3cm (89.49 in.)
	Cutting width : Mowing by 5 units	281.5cm (110.83 in.)
Engine	Model	KubotaD1105-T (Diesel Turbo)
	Type	Vertical 3-cylinder 4-cycle liquid cooled Diesel
	Displacement	1,233cc (68.53 cu-in)
	Engine speed (with no load)	1,400 – 3,000rpm
	Rated output	24.5kw (33.3ps) (32.86 hp)/3,000rpm
	Fuel consumption rate at 3,000 rpm	255g/kw.h (188g/ps.h)
	Engine oil for use	API service grade CF or higher quality, SAE viscosity 10W-30
	Battery	75D23L
Capacity	Engine oil capacity	3.1 L (0.82 U.S.gals) (including filter)
	Coolant capacity	6 L (1.59 U.S.gals) (including reserve tank)
	Fuel tank capacity	28 L (7.40 U.S.gals) (JIS No.2 Light oil)
	Hydraulic tank capacity	24 L (6.34 U.S.gals) (Equivalent of Shell Tellus 46 : ISO VG46)
	Grease (Main unit and work machine)	Excelite EP No.2 (Urea thickener series No.2)

Maintenance schedule

The maintenance schedule is as follows:

⚠ Caution

When performing maintenance, use appropriate tools, suitable for the purpose.

○: Inspection, adjustment, refill, and cleaning

●: Replacement

Maintenance items	Before /After work	Every 50 hours	Every 100 hours	Every 200 hours	Every 500 hours	Every 6 months	Every year	Remarks
Engine	Engine oil	○	● First time	●				
	Engine oil filter		● First time	●				
	Radiator, Oil cooler and Radiator cover	○						
	Coolant	○					●	
	Air cleaner element	○			●		○	
	Tension and damage of Fan belt	○				●		Every 500 hours or every 2 years, whichever comes first
	Battery fluid						○	
	Fuel filter					●		
Cleaning of exterior	○ After work							

Reference

Maintenance items		Before /After work	Every 50 hours	Every 100 hours	Every 200 hours	Every 500 hours	Every 6 months	Every year	Remarks
Main unit	Tire air pressure/cracks	○							
	Hydraulic oil	○		● First time		●			
	Hydraulic cartridge filter			● First time		●			
	Brake effectiveness	○							
	Oil leakage from each part	○							
	Tightening and damage of each part	○							
	Grease-up			○					
	Oil leakage from each part	○							
	Cleaning/inspection of each part	○ After work							
Activation of safety devices	○								
Work machine	Tightening of each part	○							
	Cleaning/inspection of each part	○							
	Reel cutter blade engagement	○							
	Grease-up			○					
	Backlash of front roller bearing			○					

Hydraulic circuit diagram

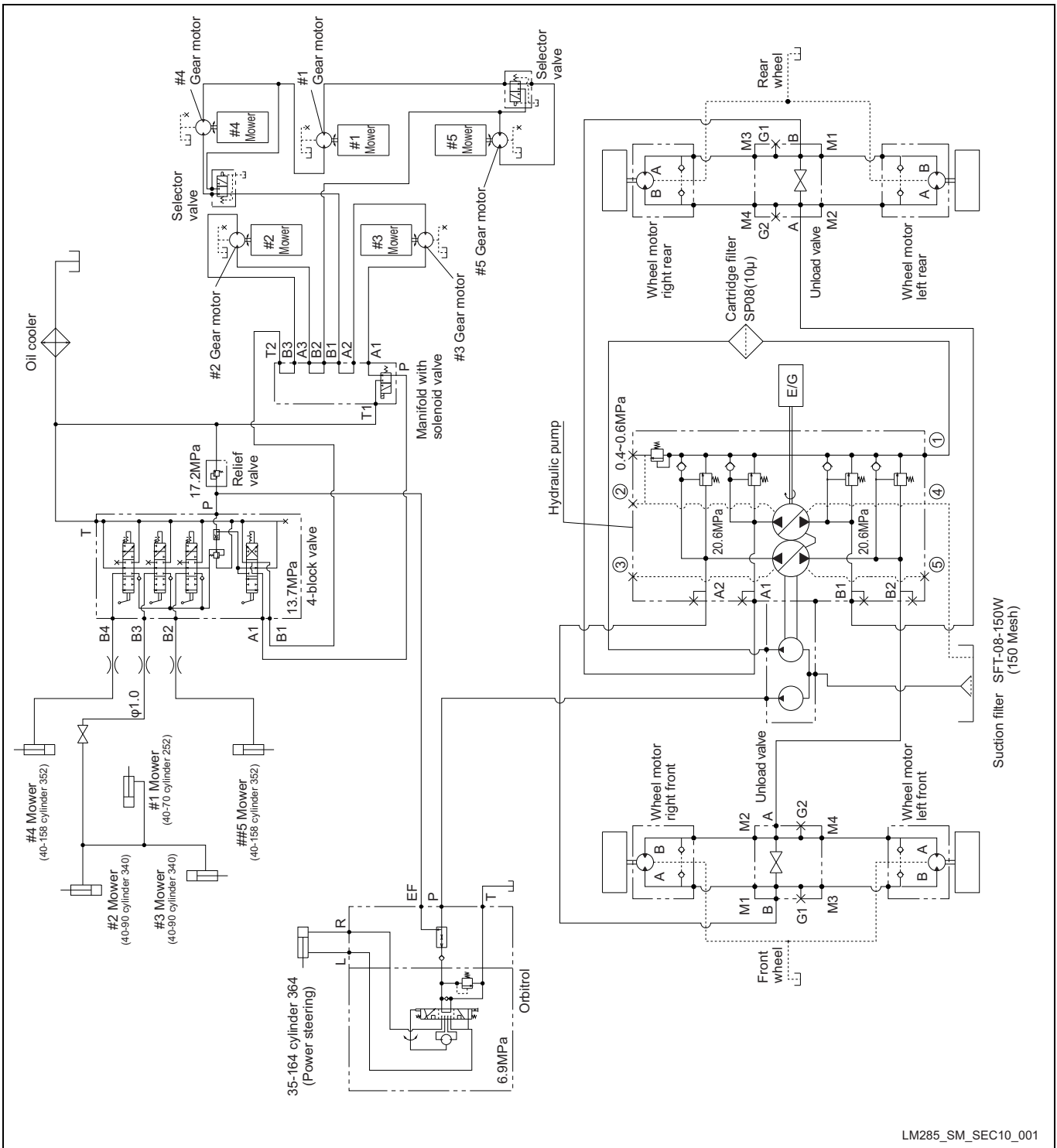

Figure: Reference-1-a

LM285_SM_SEC10_001

Electrical wiring diagram

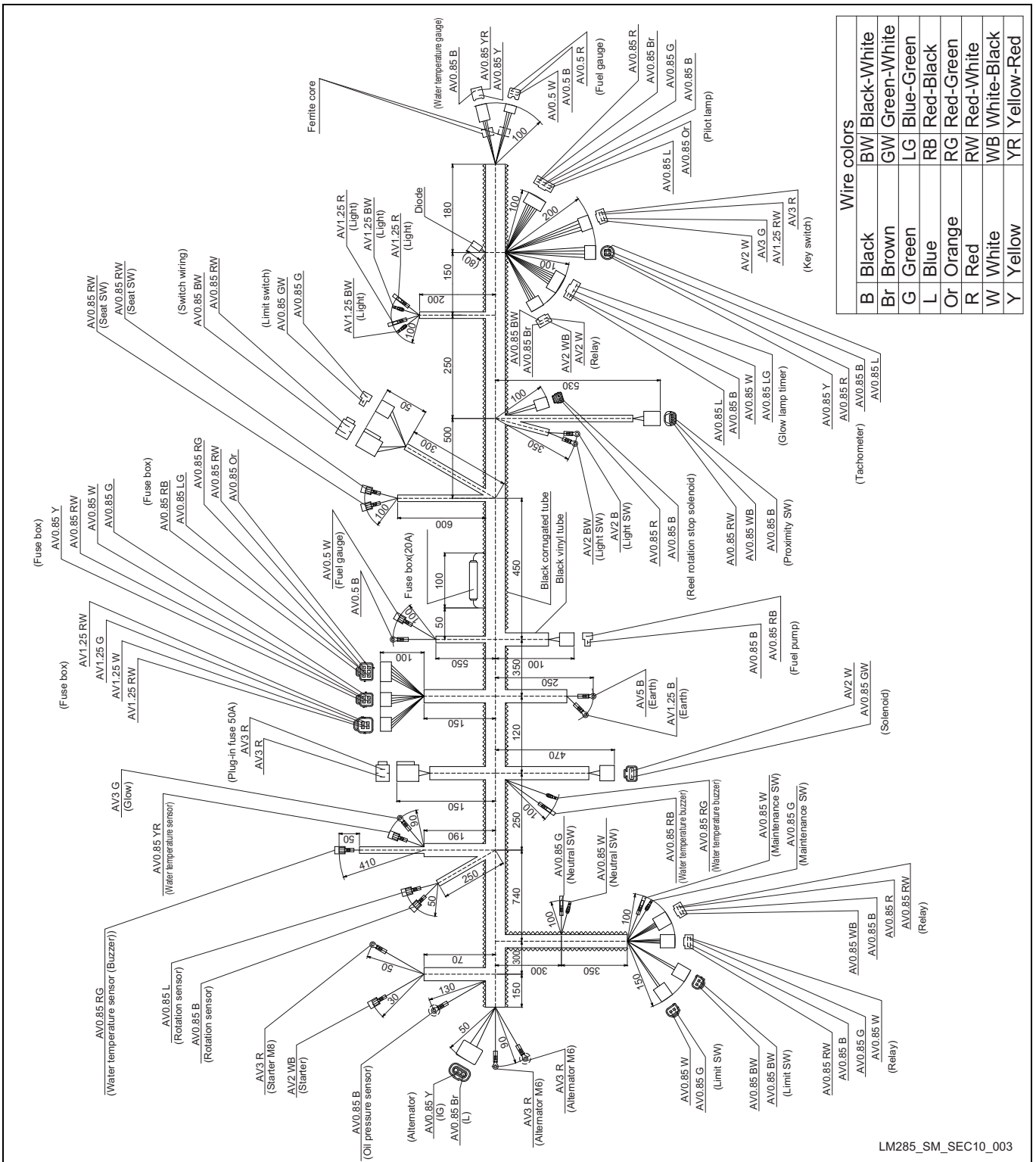
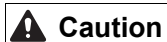

Figure: Reference-3-a

Reference

Consumable parts list

The consumable parts are follows:



Use appropriate tools, suitable for the purpose for replacement.

		Code	Part name	Qty	Remarks
Engine	Fanbelt	PF1G345-9701-0	BELT, FAN (36)	1	
	Engine oil filter	PF16271-3209-3	OIL ELEMENT	1	
	Fuel filter	PF15231-4356-0	FUEL ELEMENT	1	
	Air cleaner element	PFT0270-1632-0	ELEMENT, AIR CLEANER	1	
Main unit (incl.hydraulic and electrical system)	Suction filter	K3413000020	FILTER, SUCTION SFT-08-150W	1	
	Hydraulic cartridge filter	K3412000060	FILTER, FOR THE SUBSTITUTE C-SP08H-10	1	
	Hydraulic oil	K2913100200	SHELL TELLUS 46 20L CAN	—	
	Starter relay	PF1K574-6022-0	RELAY COMP	1	
	Glow lamp timer	PF15694-6599-0	TIMER, GLOW LAMP	1	
	Safety switch relay	K3681000060	RELAY, CALAF-12V-N-5	2	
	Fusible link	K3631000100	PLUG-IN FUSE 50A	1	
	Mini fuse block Mini fuse block	K3631000070	FUSE, MINI BLADE TYPE 5A	1	
	Fuse	K3631000040	CARTRIDGE FUSE 20A	1	
	Parking brake switch	K3670000120	SWITCH, LIMIT D4A-4717N	1	
	Reel rotation switch	K3670000140	SWITCH, LIMIT SWAZ7121NO	2	
	Neutral switch	K3671000050	SWITCH, LIMIT SL1-A	1	
	Maintenance switch	K3670000130	SWITCH, LIMIT AZ3725-1	1	
	Brake shoe right rear	P741-8007-00	SHOE ASSY	1	
	Brake shoe right front	P741-8005-00	SHOE ASSY	1	
	Brake shoe left rear	P741-8008-00	SHOE ASSY	1	
	Brake shoe left front	P741-8006-00	SHOE ASSY	1	
	Brake wire right	K1120125000	WIRE, BRAKE 1250	1	
	Brake wire left	K1120102000	WIRE, BRAKE 1020	1	
Parking brake wire	K1120141010	WIRE, BRAKE 1410	1		
Throttle wire	K1110101000	WIRE, THROTTLE 1010	1		

		Code	Part name	Qty	Remarks
Work machine (mower unit)	Bedknife	K2510000030	BED-KNIFE (BOTTOM BLADE), 85-662	5	
	Reel cutter (9) for motor right	K285260R90R	REEL CUTTER (CYLINDER), 660-9R	3	#1,2,5: 9-blade
	Reel cutter (7) for motor right	K285260R70R	REEL CUTTER (CYLINDER), 660-7R	3	#1,2,5: 7-blade
	Reel cutter (5) for motor right	K285260R50R	REEL CUTTER (CYLINDER), 660-5R	3	#1,2,5: 5-blade
	Reel cutter (9) for motor left	K285260L90R	REEL CUTTER (CYLINDER), 660-9L	2	#3,4: 9-blade
	Reel cutter (7) for motor left	K285260L70R	REEL CUTTER (CYLINDER), 660-7L	2	#3,4: 7-blade
	Reel cutter (5) for motor left	K285260L50R	REEL CUTTER (CYLINDER), 660-5L	2	#3,4: 5-blade



BARONESS
Quality on Demand

Postadress:

TRÄDGÅRDSTEKNIK AB
Helsingborgsvägen 578, Varalöv
262 96 ÄNGELHOLM

Telefon : 0431-222 90
Bg.nr : 5743-7980
Org.nr : 556409-6120

URL:

www.tradgardsteknik.se
E-postadress:
info@tradgardsteknik.se